



PLASMA DISPLAY TV

Chassis : D75A(N_42HD)_Cadillac
Model : HPS4253X/XAA

SERVICE Manual

PLASMA DISPLAY TV



HP-S4253

FEATURES

- NTSC/ATSC Tuner Built-In
- 13-Bit Processing (549 Billion Colors)
- Split Screen & Picture-In-Picture
- Samsung DNle™
(Digital Natural Image engine)
- SRS TruSurround XT™
- 2 HDMI Input
- Energy Saving
- SAMSUNG EPG System



This Service Manual is a property of Samsung Electronics Co.,Ltd.
Any unauthorized use of Manual can be punished under applicable
International and/or domestic law.

© Samsung Electronics Co., Ltd. **May. 2006**
Printed in Korea
AA82-03550A

Table of Contents

Chapter 1 Precaution

■ 1-1 Safety Precautions	1-1
■ 1-2 Servicing Precautions	1-3
■ 1-3 Static Electricity Precautions	1-4
■ 1-4 Installation Precautions	1-5

Chapter 2 Product Specification

■ 2-1 Product Features	2-1
■ 2-2 Key Features	2-2
■ 2-3 Specifications Analysis	2-5
■ 2-4 Accessories	2-6

Chapter 3 Alignment & Adjustment

■ 3-1 Service Instruction	3-1
■ 3-2 How to Access Service Mode	3-2
■ 3-3 Factory Data	3-3
■ 3-4 Service Adjustment	3-21
■ 3-5 Software Upgrade	3-25
■ 3-6 Replacements & Calibration	3-26

Chapter 4 Exploded View & Part List

■ 4-1 HPS4253X/XAA	4-1
--------------------------	-----

Chapter 5 Electrical Part List

■ 5-1 HPS4253X/XAA Service Item	5-1
---------------------------------------	-----

Chapter 6 Troubleshooting

■ 6-1 First Checklist for Troubleshooting	6-1
■ 6-2 Checkpoints by Error Mode	6-2
■ 6-3 Troubleshooting Procedures by ASS'Y	6-13

Chapter 7 Block Diagram

■ 7-1 Overall Block Diagram	7-1
■ 7-2 Partial Block Diagram	7-3

Chapter 8 Wiring Diagram

■ 8-1 Overall Wiring	8-1
■ 8-2 Partial Wiring	8-3

Chapter 9 PCB Diagram

■ 9-1 Overall PCB Diagram	9-1
---------------------------------	-----

Chapter 10 Schematic Diagram

■ 10-1 MAIN POWER BLOCK	10-1
■ 10-2 STANDBY MICOM (S3F866B)	10-2
■ 10-3 SOUND PROCESSOR (STV8257)	10-3
■ 10-4 SOUND AMP (STA323W) & POP SOLUTION	10-4
■ 10-5 TUNER & SPLITTER	10-5
■ 10-6 AV INPUT / OUTPUT	10-6
■ 10-7 SIDE-AV & ANYNET & SUB FUNCTION I/F	10-7
■ 10-8 PC & HDMI INPUT	10-8
■ 10-9 VIDEO DECODER & SCALER (SVP-PX)	10-9
■ 10-10 SVP-PX DDR MEMORY	10-10
■ 10-11 SVP-PX POWER BLOCK	10-11
■ 10-12 LBE & PWM CONTROL & PANEL I/F	10-12
■ 10-13 LAKE (I2C & GPIO & USB & UART & INT)	10-13
■ 10-14 LAKE (I2S IN/OUT & TS-IN & YCbCr-OUT)	10-14
■ 10-15 LAKE (DDR MEMORY)	10-15
■ 10-16 LAKE (STATIC MEMORY & DEBUG)	10-16
■ 10-17 LAKE (POWER BLOCK)	10-17
■ 10-18 MPEG ENCODER (SAA6752)	10-18
■ 10-19 TC90103AFG	10-19

Chapter 11 Operation Instruction & Installation

■ 11-1 Product Features and Functions	11-1
■ 11-2 New Features	11-5
■ 11-3 Installation Notes and Precautions	11-7

Chapter 12 Disassembly & Reassembly

■ 12-1 Overhaul Disassembly & Reassembly	12-1
--	------

Chapter 13 Circuit Description

■ 13-1 Power ON/OFF Signal Timing Sequence	13-1
■ 13-2 Partial Block Description	13-2

Chapter 14 Reference Information

■ 14-1 Other issues related to other products	14-1
■ 14-2 Technical Terms	14-3

1. Precaution

To avoid possible damages or electric shocks or exposure to radiation, follow the instructions below with regard to safety, installation, service and ESD.

1-1 Safety Precautions

1. Make sure all protective devices are properly installed including non-metallic handles and compartment covers when installing or re-installing the chassis or chassis assemblies.
2. Make sure that no gaps exist between the cabinets for children to insert their fingers in to prevent children from receiving electric shocks. Gaps mentioned above include ventilation holes of a too great magnitude between the PDP module and the cabinet mask, and the improper installation of the rear cabinet.

Errors may occur when the resistance is below 1.0 M Ω or over 5.2 M Ω .

In these cases, make sure that the device is repaired before sending it back to the customer.

3. Check for Electricity Leakage (Figure 1-1)
Warning: Do not use an insulated transformer for checking the leakage. Use only those current leakage testers or mirroring systems that comply with ANSIC 101.1 and the Underwriter Laboratory's specifications (UL1410, 59.7).

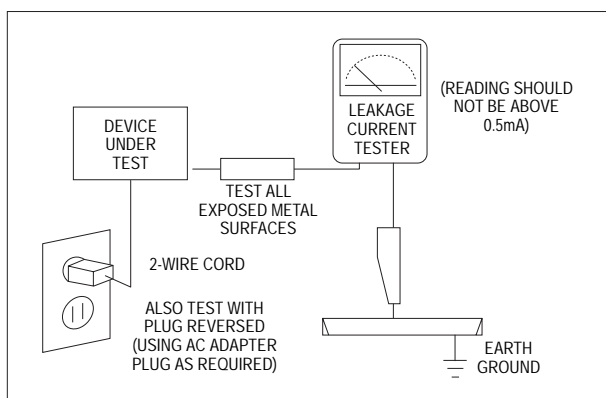

Fig. 1-1 AC Leakage Test

4. A high voltage is maintained within the specified limits using safety parts, calibration and tolerances. When voltage exceeds the specified limits, check each special part.

5. Warning for Engineering Changes:
Never make any changes or additions to the circuit design or the internal part for this product.
Ex: Do not add any audio or video accessory connectors. This might cause physical damage.
Furthermore, any changes or additions to the original design/engineering will invalidate the warranty.
6. Warning - Hot Chassis:
Some TV chassis are directly connected to one end of the AC power cord for electrical reasons.
Without insulated transformers, the product can only be repaired safely when the chassis is connected to the earthed end of the AC power source.



To make sure the AC power cord is properly connected, follow the instructions below. Use the voltmeter to measure the voltage between the chassis and the earthed ground. If the measurement is over 1.0V, unplug the AC power cord and change the polarity before re-inserting it. Measure the voltage between the chassis and the ground again.

7. Some TV chassis are shipped with an additional secondary grounding system. The secondary system is adjacent to the AC power line. These two grounding systems are separated in the circuit using an unbreakable/unchangeable insulation material.
8. When any parts, material or wiring appear overheated or damaged, replace them with new regular ones immediately. When any damage or overheating is detected, correct this immediately and make a regular check of possible errors.
9. Check for the original shape of the lead, especially that of the antenna wiring, any sharp edges, the AC power and the high voltage power. Carefully check if the wiring is too tight, incorrectly placed or loose. Never change the space between the part and the printed circuit board. Check the AC power cord for possible damages. Keep the part or the lead away from any heat-emitting materials.

Precaution

10. Safety Indication:

Some electrical circuits or device related materials require special attention to their safety features, which cannot be viewed by the naked eye. If an original part is replaced with another irregular one, the safety or protective features will be lost even if the new one has a higher voltage or more watts.

Critical safety parts should be bracketed with ( ). Use only regular parts for replacements (in particular, flame resistance and dielectric strength specifications). Irregular parts or materials may cause electric shock or fire.

1-2 Servicing Precautions

Warning 1: First carefully read the "Safety Instruction" in this service manual.

When there is a conflict between the service and the safety instructions, follow the safety instruction at all times.

Warning 2: Any electrolytic capacitor with the wrong polarity will explode.

1. The service instructions are printed on the cabinet, and should be followed by any service personnel.
2. Make sure to unplug the AC power cord from the power source before starting any repairs.
 - (a) Remove or re-install parts or assemblies.
 - (b) Disconnect the electric plug or connector, if any.
 - (c) Connect the test part in parallel with the electrolytic capacitor.
3. Some parts are placed at a higher position than the printed board. Insulated tubes or tapes are used for this purpose. The internal wiring is clamped using buckles to avoid contact with heat emitting parts. These parts are installed back to their original position.
4. After the repair, make sure to check if the screws, parts or cables are properly installed. Make sure no damage is caused to the repaired part and its surroundings.
5. Check for insulation between the blade of the AC plug and that of any conductive materials (i.e. the metal panel, input terminal, earphone jack, etc).
6. Insulation Check Process: Unplug the power cord from the AC source and turn the switch on. Connect the insulating resistance meter (500v) to the AC plug blade.
7. Any B+ interlock should not be damaged. If the metal heat sink is not properly installed, no connection to the AC power should be made.
8. Make sure the grounding lead of the tester is connected to the chassis ground before connecting to the positive lead. The ground lead of the tester should be removed last.
9. Beware of risks of any current leakage coming into contact with the high-capacity capacitor.
10. The sharp edges of the metal material may cause physical damage, so ensure wearing protective gloves during the repair.
11. Due to the nature of plasma display panels, partial after-images may appear if a still picture is displayed on the screen for a long period of time.
This is caused by brightness deterioration due to the storage effect of the panel, and to prevent this from happening, we recommend that the brightness and contrast are reduced.
(e.g.) Contrast: 25, Brightness: 50

The insulating resistance between the blade of the AC plug and that of the conductive material should be more than 1 M Ω .

1-3 Static Electricity Precautions

1. Some semi-conductive ("solid state") devices are vulnerable to static electricity. These devices are known as ESD. ESD includes the integrated circuit and the field effect transistor. To avoid any materials damage from electrostatic shock, follow the instructions described below.
2. Remove any static electricity from your body by connecting the earth ground before handling any semi-conductive parts or ass'ys. Alternatively, wear a dischargeable wrist-belt.
(Make sure to remove any static electricity before connecting the power source - this is a safety instruction for avoiding electric shock)
3. Remove the ESD ass'y and place it on a conductive surface such as aluminum foil to prevent accumulating static electricity.
4. Do not use any Freon-based chemicals. Such chemicals will generate static electricity that causes damage to the ESD.
5. Use only grounded-tip irons for soldering purposes.
6. Use only anti-static solder removal devices. Most solder removal devices do not support an anti-static feature. A solder removal device without an anti-static feature can store enough static electricity to cause damage to the ESD.
7. Do not remove the ESD from the protective box until the replacement is ready. Most ESD replacements are covered with lead, which will cause a short to the entire unit due to the conductive foam, aluminum foil or other conductive materials.
8. Remove the protective material from the ESD replacement lead immediately after connecting it to the chassis or circuit ass'y.
9. Take extreme caution in handling any uncovered ESD replacements. Actions such as brushing clothes or lifting your leg from the carpet floor can generate enough static electricity to damage the ESD.

CAUTION

These servicing instructions are for use by qualified service personnel only. To reduce the risk of electric shock do not perform any servicing other than that contained in the operating instructions unless you are qualified to do so.

1-4 Installation Precautions

1. For safety reasons, more than two people are required for carrying the product.

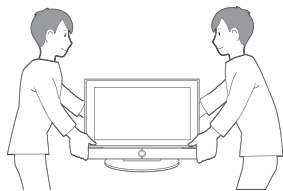

2. Keep the power cord away from any heat emitting devices, as a melted covering may cause fire or electric shock.
3. Do not place the product in areas with poor ventilation such as a bookshelf or closet. The increased internal temperature may cause fire.
4. Bend the external antenna cable when connecting it to the product. This is a measure to protect it from being exposed to moisture. Otherwise, it may cause a fire or electric shock.
5. Make sure to turn the power off and unplug the power cord from the outlet before repositioning the product. Also check the antenna cable or the external connectors if they are fully unplugged. Damage to the cord may cause fire or electric shock.
6. Keep the antenna far away from any high-voltage cables and install it firmly. Contact with the high-voltage cable or the antenna falling over may cause fire or electric shock.
7. When connecting the RF antenna, check for a DTV receiving system and install a separate DTV reception antenna for areas with no DTV signal.
8. When installing the product, leave enough space (4") between the product and the wall for ventilation purposes. A rise in temperature within the product may cause fire.
9. When moving a PDP with removable speakers, detach the speakers first before moving the main body. Moving the PDP main body without separating the speakers may cause the speakers to detach, possibly causing damage or injury.

MEMO

2. Product Specification

2-1 Product Features

Block	Specification	Major IC	Remark
RF	Digital/Analog (DTV Built In)	VSB NIM Tuner S5H2111X01(Lake)	
PDP Module	Samsung SDI V5.1 Module	42" HD	New Module
Power	Samsung electro mechanics SMPS	42" HD SMPS	New SMPS
Video	NTSC 3.58, ATSC HDMI DNle(LBE) Component, PC	Lake SDP54	
Sound	Speaker : 10W+10W SRS TruSurround XT, Dolby Digital	STV8258, STA323W	Optical, Coaxial Output
Cabinet	Q7 Design		New Cabinet

■ Chip Description

- DNVS303HH261A Tuner : ATSC/NTSC VSB NIM Tuner
- SVP PX : Component, CVBS, Y/C, HDMI, PC input Video signal processor
- SDP54 : The DNle IC for visual quality improvement. (LBE)
- STV8258 : Sound Processing IC
- STA323W : Sound AMP IC
- S5H2111X01 : MPEG Decoder IC (Lake)
- 3F8668 : Generates various control signals required for operating the circuit.
The software is downloaded through PC D-SUB Jack. (Sub Micom)

2-2 Key Features

Model	HP-S4253	
Dimensions	Display	41.5 (W) x 28 (H) x 3.8 (D) inches (Without Stand)
		41.5 (W) x 29.8 (H) x 13.4 (D) inches (With Stand)
Weight	Display	34.2 kg / 75.4 lbs (Without Stand)
		40 kg / 88.2 lbs (With Stand)
Voltage	AC 110-230V \pm 10%, 60Hz	
Power Consumption	380 W	
Number of Pixels	1024(H) x 768(V)	
Screen Size	42 inches	
ANTENNA input	ANT 1 - CABLE IN ANT 2 - AIR IN ※ 75 Ω unbalanced	
VIDEO input	AV1, AV2 S-VIDEO1, S-VIDEO2 COMPONENT1 - 480i/480p/720p/1080i COMPONENT2 - 480i/480p/720p/1080i PC HDMI1 (DVI Compatible) - 480p/720p/1080i HDMI2 - 480p/720p/1080i	
AUDIO input	AV1, AV2 S-VIDEO1, S-VIDEO2 COMPONENT1 - 480i/480p/720p/1080i COMPONENT2 - 480i/480p/720p/1080i PC DVI	
AV Output	AUDIO (L/R)	
Speaker Output	10W + 10W (8 Ω)	
Audio Output	OPTICAL(DIGITALOUT) COAXIAL(DIGITALOUT)	
ETC	DNIe (LBE), Anynet, Color Weakness, My Color Control, SRS TruSurround XT, Dolby Digital, Built-in Speaker/Stand	
New Function	blue eye	

■ H/W Configuration

- DTV Module : S5H2111X01 (Lake, MPEG+CPU 1chip)
- Video : SVP PX, SDP54
- Sound : STV8258, STA323W
- Tuner : UMX-NT-059 (RF-Splitter), DNVS303HH261A (VSB NIM Tuner)
- CPU : S3C2800X01, S3F866B, P_PCFM_012

■ S/W Configuration

- Main Program : JS28F640 (Flash memory)
- Sub-Micom : S3F866B
- DDC : 24C02 x2 (Analog DDC Data, Digital DDC Data)
- EEPROM : 24C256 (White balance data and Factory initial data)

Picture

- System : Video → ATSC / NTSC
- Progressive
- Output resolution : 1024 x 768
- OSD : Smart user Interface Grade 1
- Picture Enhancement : DNIe (LBE)
- Still picture, Noise reduction
- Comb Filter : 3D comb filter
- PIP : Large, Double1, Double2
- Picture Size : 16:9, Zoom1, Zoom2, 4:3 (AV, S-Video, Component 480i/480p)
16:9, 4:3 (Component 720p/1080i, PC, HDMI)

Sound

- System : Stereo
- Dolby Digital, TruSurround XT
- Output : 10W + 10W
- Speaker : Built-in
- Optical/Coaxial Sound Output : Dolby Digital, PCM (DTV), PCM (HDMI)

Feature

- Component Interface (480i/480p/720p/1080i, Y/Pb/Pr)
- Digital Interface : HDMI (480p/720p/1080i)
- Auto Program
- Sleep Timer : 180 Minutes
- Anynet Interface
- My Color Control
- Color Weakness
- Energy Saving
- Screen Burn Protection

In/Out Terminals

- 1 Monitor audio Output
- 2 Component Inputs
- 15 Pin PC D-sub Input
- 2 HDMI Input
- 2 SPDIF Output (Optical, Coaxial)
- 2 RF Input : Cable/Air
- 2 AV Inputs
- 2 S-Video Inputs

Remocon

- TM87B

Power Supply

- 110V~, 60Hz

Note



- You can input the DVI signal using the DVI ↔ HDMI conversion cable.
- When connecting HDMI input using the DVI ↔ HDMI conversion cable, connect the sound signal to the DVI Audio IN port using a separate connection cable.

- Both screen position and size will vary, depending on the type of PC monitor and its resolution.
The table below shows all of the display modes that are supported: (N : Negative, P : Positive)













Video Signal	Resolution (Dot X Line)	Vertical Frequency (Hz)	Horizontal Frequency (KHz)	Vertical Polarity	Horizontal Polarity
IBM PC / AT Compatible	640 X 350	70.086	31.469	N	P
	720 X 400	70.087	31.469	P	N
	640 X 480	59.940	31.469	N	N
		70.000	35.000	N/P	N/P
		72.809	37.861	N	N
		75.000	37.500	N	N
	800 X 600	56.250	35.156	N/P	N/P
		60.317	37.879	P	P
		70.000	43.75	N/P	N/P
		72.188	48.077	P	P
		75.000	46.875	P	P
	1024 X 768	60.004	48.363	N	N
		70.069	56.476	N	N
		72.000	57.672	N/P	N/P
		75.029	60.023	P	P

- ▶ The interlace mode is not supported.
- ▶ The TV operates abnormally if a non-standard video format is selected.
- ▶ The table above conforms to IBM/VESA regulations and is based on using the Analog Input.

2-3 Specifications Analysis

Model		HP-S4253	HP-P4261	HP-R4272C
Design				
Basic	Display Type	PDP TV	PDP TV	PDP TV
	Built-In Tuner	○	X	○
	Resolution	1024 x 768	1024 x 768	1024 x 768
	PDP Module	Samsung SDI V5.1	Samsung SDI V3	Samsung SDI V4
	Screen Size	42"	42"	42"
	Picture ratio	16 : 9	16 : 9	16 : 9
	Power Consumption	380 W	330 W	380 W
	Dimensions	41.5"(W) x 28"(H) x 3.8"(D) (Without Stand)	41.4"(W) x 29.7"(H) x 3.4"(D) (Without Stand)	41.7"(W) x 29.1"(H) x 3.88"(D) (Without Stand)
Weight	75.4 Lbs (Without Stand)	79 Lbs (Without Stand)	87.7 Lbs (Without Stand)	
Picture	Brightness	1,200 Cd/m2	1,000 Cd/m2	1,500 Cd/m2
	Contrast Ratio	7,000 : 1	3,000 : 1	10,000 : 1
	Picture Enhancer	LBE	DNle 3	DNle Lite
	Comb Filter	○	○	○
Audio	Equalizer	5 Band	5 Band	5 Band
	Auto Volume Control	○	○	○
	Surround Sound	SRS TruSurround XT Dolby Digital(AC3)	SRS TruSurround XT	SRS TruSurround XT Dolby Digital
	Speaker Output	10W + 10W	15W + 15W	15W + 15W
Features	PIP	○	○	○
	Double Window	○	○	○
	Caption	○	○	○
	Still Image	○	○	○
	EPG	○	X	○
	My Color Control	○	○	○
	Color Weakness	○	○	○
	Energy Saving	○	X	○
Anynet	X	X	○	
Connections	Antenna	2 (Cable/Air)	1	2 (Cable/Air)
	AV Input	2	3	2
	S-Video	2	2	2
	Component	2	2	2
	PC(D-SUB)	1	1	1
	DVI	X	1	X
	HDMI	2	X	1
	Sub Woofer	X	1	X
	Optical	1	X	1
	Coaxial	1	X	1
ETC	Speaker/Stand	Built-in Stand	Built-in Speaker/Stand	Built-in Speaker/Stand
	FCC Class	Class B	Class B	Class B

2-4 Accessories

	Accessories	Item	Item code	Remark
Supplied Accessories		User Manual	BN68-00991B	Samsung Service center
		Remote Control AAA Batteries	BN59-00511A 4301-000103	
		Cloth-Clean	BN63-01798A	
		Power Cord	3903-000144	
Accessories that can be purchased additionally		S-VIDEO Cable	BN39-00149A	Internal shopping mall
		HDMI Cable	BN39-00641A	
		HDMI/DVI cable	BN39-00643A	
		Component Cables (RCA)	BN39-00279A	
		PC Cable	BN39-00115A	
		PC Audio Cable	BN39-00061B	
		Optical Cable	-	
		Coaxial Cable	-	
		Antenna Cable	-	

3. Alignment & Adjustment

3-1 Service Instruction

■ Before Performing After Sales Services

1. Check if the measurement and test equipment is working properly.
2. Secure sufficient work space for disassembling the product.
3. Prepare a soft pad for disassembling the product.

3-2 How to Access Service Mode

1. General Remote

To Enter : Power Off → MUTE → 1 → 8 → 2 → Power On
(Interval between key strokes : less than 3 sec)

To Exit : Power Off → On

2. Factory Remote

To Enter : Power On → INFO → FACTORY Key (Interval between key strokes : less than 3 sec)

To Exit : Power Off → On

Press the Factory key twice with a key stroke interval of more than 1 second (Pressing once enters Aging Mode)

3. Settings when entering Factory mode

- Sharp Screen (Dynamic), Color Tone (Cool1), Factory (Dynamic CE Off)

4. Adjustment Procedures

- Channel ▲▼ Key : Select an item.
- Volume ◀▶ Key : Adjust the value up or down.
- MENU Key : Save the changes to the EEPROM and return to the higher-level mode.
- Using the Numeric (0~9) keys, you can select a channel.
- Using the SOURCE key, you can switch AV modes.

5. Initial SERVICE MODE DISPLAY State

NTSC-RF	
Calibration	Checksum
Option Byte	KS1406
White Balance	KS1409
W/B Movie	Dynamic Contrast
SVP-PX	EEPROM Access Count
LBE	PDP Option
SOUND(STV825X)	RESET
Sub Micom Download	Vol=8, B/S=On, 10W, US_Mesh
T-CADINUS0H-2001 Apr 5 2006	
T-CADINUS5-0061 [Sec :20]	

※ The version of the firmware displayed at the bottom of the screen may differ and the firmware is subject to change for the improvement of product functions.

※ If you have adjusted the settings in Service Mode, you have to reset the product.

3-3 Factory Data

★ The underlined are items applied during the service adjustment. None of the others should be adjusted.

1. Calibration

ITEM	Data
AV Calibration	Off → On
Comp Calibration	Off → On
PC Calibration	Off → On
HDMI Calibration	Off → On

2. Option Byte

ITEM	Data	Range
Caption Level	16	0 ~ 1
Watchdog enable	1	
Spread Sptectrum	>>	0 ~ 1
Panel Option	0	0 ~ 1
PWM Dimming	0	0 ~ 1
NIM Version	KS1409	0 ~ 1
SIDE AV	On	
RS-232 JACK	ANYNET	
Gamma	PDP	OFF/PDP
ACR[PDP]	ACR	OFF/ACR
HSCB[PDP]	HSCB	BASE/HSCB
Panel Display Time	XX Hr	
Mute Time[RF]	2	
CH Memory	SAMEX	None/Suwon/SAMEX

3. White Balance

ITEM	Range	RF/AV/S-Video	Component	PC	HDMI/DTV
<u>Sub Brightness (LBE)</u>	0 ~ 255	128	128	128	128
<u>R-Offset</u>	0 ~ 1023	512	512	512	512
<u>G-Offset</u>	0 ~ 1023	512	512	512	512
<u>B-offset</u>	0 ~ 1023 (-512 ~ 511)	512	512	512	512
<u>Sub Contrast (LBE)</u>	0 ~ 255	128	128	128	128
<u>R-Gain</u>	0 ~ 1023	512	512	512	512
<u>G-Gain</u>	0 ~ 1023	512	512	512	512
<u>B-Gain</u>	0 ~ 1023	512	512	512	512

4. W/B Movie

■ The Common Changes when Entering into the Movie Mode (42SD/42HD/50HD All mode)

1. LBE INPUT_RGBOFFSET : 512
2. LBE COLOR_GAIN : 120
3. SVP-PX Sharpness Peakth1 : 36

■ 42SD Movie Mode Option Item

** 42SD Movie Skin Value **

1. RF : x-1560, y-1630
2. AV : x-1560, y-1630
3. 480i : x-1550, y-1620
4. 480p : x-1580, y-1620
5. 720p/1080i : x-1690, y-1630

■ 42HD Movie Mode Option Item

1. RF : x-1490, y-1655
2. AV : x-1500, y-1700
3. 480i : x-1570, y-1655
4. 480p : x-1570, y-1655
5. 720p/1080i : The same as Dynamic

■ 50HD Movie Mode Option Item

1. RF/Video : x-1470, y-1660
2. Comp 480i : x-1580, y-1640
3. Comp 480p : x-1680, y-1700
4. Comp 720p : The same as Dynamic
5. Comp 1080i : x-1760, y-1660

ITEM	42SD RF/AV				42HD RF/AV				50HD RF/AV			
W/B Movie On/Off	Off				Off				Off			
Mode	Dynamic				Dynamic				Dynamic			
Color Tone	Cool2	Normal	Warm1	Warm2	Cool2	Normal	Warm1	Warm2	Cool2	Normal	Warm1	Warm2
W1_RGain			17				22				16	
W1_BGain			-29				-30				-31	
W1_ROffset			2				-3				-2	
W1_BOffset			-2				1				-2	
W2_RGain				27				27				22
W2_BGain				-50				-48				-43
W2_ROffset				-1				-3				-1
W2_BOffset				1				2				-2
NOR_RGain		2				19				6		
NOR_BGain		-21				-12				-10		
NOR_ROffset		3				-6				-1		
NOR_BOffset		0				0				-4		
C2_RGain	-20				2				-7			
C2_BGain	14				16				21			
C2_ROffset	9				-3				0			
C2_BOffset	1				0				-5			
Movie Contrast	55	55	55	55	55	55	55	55	55	55	55	55
Movie Bright	55	55	55	55	55	55	55	55	55	55	55	55
Movie Color	20	20	20	20	20	20	20	20	20	20	20	20
Movie Sharpness	30	30	30	30	30	30	30	30	30	30	30	30

ITEM	42SD HDMI/DTV				42HD HDMI/DTV				50HD HDMI/DTV			
W/B Movie On/Off	Off				Off				Off			
Mode	Dynamic				Dynamic				Dynamic			
Color Tone	Cool2	Normal	Warm1	Warm2	Cool2	Normal	Warm1	Warm2	Cool2	Normal	Warm1	Warm2
W1_RGain			21				8				20	
W1_BGain			-39				-28				-27	
W1_ROffset			-1				-1				0	
W1_BOffset			5				0				0	
W2_RGain				27				10				23
W2_BGain				-50				-45				-40
W2_ROffset				0				1				4
W2_BOffset				3				1				0
NOR_RGain		9				3				6		
NOR_BGain		-15				-10				-16		
NOR_ROffset		-1				-1				1		
NOR_BOffset		1				-1				2		
C2_RGain	-5				-4				-9			
C2_BGain	9				5				14			
C2_ROffset	-2				-2				2			
C2_BOffset	0				3				-1			
Movie Contrast	55	55	55	55	55	55	55	55	55	55	55	55
Movie Bright	55	55	55	55	55	55	55	55	55	55	55	55
Movie Color	20	20	20	20	20	20	20	20	20	20	20	20
Movie Sharpness	30	30	30	30	30	30	30	30	30	30	30	30

ITEM	42SD Component				42HD Component				50HD Component			
W/B Movie On/Off	Off				Off				Off			
Mode	Dynamic				Dynamic				Dynamic			
Color Tone	Cool2	Normal	Warm1	Warm2	Cool2	Normal	Warm1	Warm2	Cool2	Normal	Warm1	Warm2
W1_RGain			19				8				15	
W1_BGain			-40				-29				-33	
W1_ROffset			0				0				2	
W1_BOOffset			7				0				2	
W2_RGain				26				13				20
W2_BGain				-48				-46				-46
W2_ROffset				1				1				1
W2_BOOffset				3				1				1
NOR_RGain		10				4				4		
NOR_BGain		-16				-12				-18		
NOR_ROffset		-1				-1				3		
NOR_BOOffset		1				-1				2		
C2_RGain	-5				-2				-12			
C2_BGain	12				5				5			
C2_ROffset	-2				-2				4			
C2_BOOffset	1				1				4			
Movie Contrast	55	55	55	55	55	55	55	55	55	55	55	55
Movie Bright	55	55	55	55	55	55	55	55	55	55	55	55
Movie Color	20	20	20	20	20	20	20	20	20	20	20	20
Movie Sharpness	30	30	30	30	30	30	30	30	30	30	30	30

ITEM	42SD RF/AV				42HD RF/AV				50HD RF/AV			
W/B Movie On/Off	Off				Off				Off			
Mode	Movie				Movie				Movie			
Color Tone	Cool2	Normal	Warm1	Warm2	Cool2	Normal	Warm1	Warm2	Cool2	Normal	Warm1	Warm2
W1_RGain	The same as Dynamic		10		The same as Dynamic		21		The same as Dynamic		13	
W1_BGain			-51				-48				-46	
W1_ROffset			9				3				5	
W1_BOOffset			10				6				4	
W2_RGain				30				0				21
W2_BGain				-82				-112				-84
W2_ROffset				2				10				5
W2_BOOffset				-4				11				3
NOR_RGain												
NOR_BGain												
NOR_ROffset												
NOR_BOOffset												
C2_RGain												
C2_BGain												
C2_ROffset												
C2_BOOffset												
Movie Contrast	55	55	55	55	55	55	55	55	55	55	55	55
Movie Bright	55	55	55	55	55	55	55	55	55	55	55	55
Movie Color	20	20	20	20	20	20	20	20	20	20	20	20
Movie Sharpness	30	30	30	30	30	30	30	30	30	30	30	30

ITEM	42SD HDMI/DTV				42HD HDMI/DTV				50HD HDMI/DTV			
W/B Movie On/Off	Off				Off				Off			
Mode	Movie				Movie				Movie			
Color Tone	Cool2	Normal	Warm1	Warm2	Cool2	Normal	Warm1	Warm2	Cool2	Normal	Warm1	Warm2
W1_RGain	The same as Dynamic		11		The same as Dynamic		29		The same as Dynamic		36	
W1_BGain			-55				-35				-41	
W1_ROffset			6				-10				-12	
W1_BOOffset			7				-3				-1	
W2_RGain				51				35				23
W2_BGain				-83				-86				-80
W2_ROffset				-2				-10				3
W2_BOOffset				8				1				1
NOR_RGain												
NOR_BGain												
NOR_ROffset												
NOR_BOOffset												
C2_RGain												
C2_BGain												
C2_ROffset												
C2_BOOffset												
Movie Contrast	55	55	55	55	55	55	55	55	55	55	55	55
Movie Bright	55	55	55	55	55	55	55	55	55	55	55	55
Movie Color	20	20	20	20	20	20	20	20	20	20	20	20
Movie Sharpness	30	30	30	30	30	30	30	30	30	30	30	30

ITEM	42SD Component				42HD Component				50HD Component			
W/B Movie On/Off	Off				Off				Off			
Mode	Movie				Movie				Movie			
Color Tone	Cool2	Normal	Warm1	Warm2	Cool2	Normal	Warm1	Warm2	Cool2	Normal	Warm1	Warm2
W1_RGain	The same as Dynamic		21		The same as Dynamic		23		The same as Dynamic		12	
W1_BGain			-49				-39				-48	
W1_ROffset			3				-2				5	
W1_BOOffset			9				2				3	
W2_RGain				31				15				22
W2_BGain				-86				-69				-88
W2_ROffset				5				-8				3
W2_BOOffset				7				-3				3
NOR_RGain												
NOR_BGain												
NOR_ROffset												
NOR_BOOffset												
C2_RGain												
C2_BGain												
C2_ROffset												
C2_BOOffset												
Movie Contrast	55	55	55	55	55	55	55	55	55	55	55	55
Movie Bright	55	55	55	55	55	55	55	55	55	55	55	55
Movie Color	20	20	20	20	20	20	20	20	20	20	20	20
Movie Sharpness	30	30	30	30	30	30	30	30	30	30	30	30

ITEM	42SD PC				42HD PC				50HD PC			
W/B Movie On/Off	Off				Off				Off			
Mode	Dynamic / Movie				Dynamic / Movie				Dynamic / Movie			
Color Tone	Cool2	Normal	Warm1	Warm2	Cool2	Normal	Warm1	Warm2	Cool2	Normal	Warm1	Warm2
W1_RGain			21				8				20	
W1_BGain			-39				-28				-27	
W1_ROffset			-1				-1				0	
W1_BOffset			5				0				0	
W2_RGain				27				10				23
W2_BGain				-50				-45				-40
W2_ROffset				0				1				4
W2_BOffset				3				1				0
NOR_RGain		9				3				6		
NOR_BGain		-15				-10				-16		
NOR_ROffset		-1				-1				1		
NOR_BOffset		1				-1				2		
C2_RGain	-5				-4				-9			
C2_BGain	9				5				14			
C2_ROffset	-2				-2				2			
C2_BOffset	0				3				-1			
Movie Contrast	55	55	55	55	55	55	55	55	55	55	55	55
Movie Bright	55	55	55	55	55	55	55	55	55	55	55	55
Movie Color	20	20	20	20	20	20	20	20	20	20	20	20
Movie Sharpness	30	30	30	30	30	30	30	30	30	30	30	30

5. SVP-EX

① Sharpness

ITEM	Range	RF			AV			HDMI/DTV		
		42SD	42HD	50HD	42SD	42HD	50HD	42SD	42HD	50HD
H2gain	0 ~ 16	8	16	10	10	10	16	10	16	20
H4gain	0 ~ 16	8	16	10	10	16	16	10	16	20
V2gain	0 ~ 16	10	16	10	10	10	16	10	16	20
V4gain	0 ~ 16	10	16	10	10	16	16	10	20	20
Sr2gain	0 ~ 16	0	4	2	0	2	2	0	2	2
Sr4gain	0 ~ 16	2	4	2	2	2	2	2	4	2
Sl2gain	0 ~ 16	0	4	2	0	2	2	0	2	2
Sl4gain	0 ~ 16	2	4	2	2	2	2	2	4	2
Peakth1	0 ~ 255	4	4	4	4	4	4	4	4	4
Peakth2	0 ~ 255	47	47	47	47	47	47	47	47	47
Peakth3	0 ~ 255	63	63	63	63	63	63	63	63	63

ITEM	Range	Component											
		480i			480p			720p			1080i		
		42SD	42HD	50HD	42SD	42HD	50HD	42SD	42HD	50HD	42SD	42HD	50HD
H2gain	0 ~ 16	10	10	20	10	10	20	8	10	20	8	10	20
H4gain	0 ~ 16	10	16	20	10	16	20	8	16	20	8	16	20
V2gain	0 ~ 16	10	10	20	10	10	20	10	10	20	10	10	20
V4gain	0 ~ 16	10	16	20	10	16	20	10	16	20	10	16	20
Sr2gain	0 ~ 16	0	2	2	0	2	2	0	2	2	0	2	2
Sr4gain	0 ~ 16	2	2	2	2	2	2	2	2	2	2	2	2
Sl2gain	0 ~ 16	0	2	2	0	2	2	0	2	2	0	2	2
Sl4gain	0 ~ 16	2	2	2	2	2	2	2	2	2	2	2	2
Peakth1	0 ~ 255	4	4	4	4	4	4	4	4	4	4	4	4
Peakth2	0 ~ 255	47	47	47	47	47	47	47	47	47	47	47	47
Peakth3	0 ~ 255	63	63	63	63	63	63	63	63	63	63	63	63

② LNA PLUS

ITEM	Range	RF	AV
dB0_Peaking_th1	0 ~ 255	2	2
dB0_Vpeaking_th1	0 ~ 255	4	4
db1_NoiseAmount	0 ~ 255	10	10
dB1_Peaking_th1	0 ~ 255	12	12
dB1_Vpeaking_th1	0 ~ 255	24	24
dB2_NoiseAmount	0 ~ 255	25	20
dB2_Peaking_th1	0 ~ 255	32	32
dB2_Vpeaking_th2	0 ~ 255	32	32
dB3_NoiseAmount	0 ~ 255	40	30
dB3_Peaking_th1	0 ~ 255	128	128
dB3_Vpeaking_th1	0 ~ 255	80	80

③ Color Manage

ITEM	Range	RF	AV/S-Video	HDMI/DTV	Component	PC
DSM_Skin_Direct	0 ~ 16	0	0	0	0	0
DSM_Skin_Enhance	0 ~ 16	0	0	0	0	0
DSM_Green_Stretch	0 ~ 16	0	0	0	0	0
DSM_Blue_Stretch	0 ~ 16	0	0	0	0	0
Ss_Skin_Direct	0 ~ 16	0	0	0	0	0
Ss_Skin_Enhance	0 ~ 16	0	0	0	0	0
Ss_Green_Stretch	0 ~ 16	0	0	0	0	0
Ss_Blue_Stretch	0 ~ 16	0	0	0	0	0

④ UV Delay

ITEM	Range	RF/AV/S-Video	HDMI/DTV	Component	PC
U Delay	0 ~ 16	16	16	16	16
V Delay	0 ~ 16	16	16	16	16

⑤ PGA

ITEM	Range	RF/AV/S-Video	HDMI/DTV	Component	PC
TCD3_Contrast	0 ~ 255	113	126	126	126
TCD3_Bright	0 ~ 255	48	40	40	40
TCD3_YC_Delay	0 ~ 255	0	0	0	0
ANALOG_Y_Offset	0 ~ 255	66	66	81	22
ANALOG_PB_Offset	0 ~ 255	128	128	128	25
ANALOG_PR_Offset	0 ~ 255	128	128	128	22
ANALOG_Y_Gain	0 ~ 255	194	194	190	214
ANALOG_PB_Gain	0 ~ 255	128	128	128	128
ANALOG_PR_Gain	0 ~ 255	128	128	128	128
BlackLevel	0 ~ 255	0	0	0	0
Bright40	0 ~ 255	25	25	25	25
CAGC_Target_NotUse	0 ~ 255	170	170	170	170
User Color	0 ~ 255	127	127	127	127

⑥ Calibration Target

ITEM	Range	Data
1st_AV_Low		0x0C
1st_AV_High		0xDC
1st_AV_Delta		0x04
1st_COMP_Low		0x10
1st_COMP_High		0xEB
1st_COMP_Delta		0x04
1st_PC_Low		0x04
1st_PC_High		0xF8
1st_PC_Delta		0x04
None		
None		
None		
2nd_AV_Low		0x02
2nd_AV_High		0xE9
2nd_AV_Delta		0x10
2nd_COMP_Low		0x00
2nd_COMP_High		0xEB
2nd_COMP_Delta		0x10
2nd_PC_Low		0x00
2nd_PC_High		0xEB
2nd_PC_Delta		0x10
2nd_HDMI_Low		0x00
2nd_HDMI_High		0xEB
2nd_HDMI_Delta		0x10

⑦ CLK_A

ITEM	Range	Data
CLK_A		16

⑧ CLK_B

ITEM	Range	Data
CLK_B		96

6. LBE (Dnie)

ITEM	Range	RF			AV/S-Video			HDMI/DTV		
		42SD	42HD	50HD	42SD	42HD	50HD	42SD	42HD	50HD
PATT_SEL	0 ~ 25	0	0	0	0	0	0	0	0	0
BLACK_TILT	0 ~ 255	130	120	140	130	120	140	130	140	140
BLACK_GAIN_MAX	0 ~ 1023	400	400	400	400	400	400	380	380	400
B_RATIO		120	120	140	130	120	140	100	150	150
LOWER_FUNC		3	3	4	3	3	4	3	6	5
UPPER_FUNC		3	4	5	3	5	5	3	8	5
SKIN_EN	0 ~ 1	1	1	1	1	1	1	1	1	1
SKIN_T_X	0 ~ 4095	1790	1750	1790	1770	1750	1790	1850	1780	1820
SKIN_T_Y	0 ~ 4095	1660	1700	1660	1690	1700	1690	1630	1670	1650
WHITE_EN	0 ~ 1	0	0	0	0	0	0	0	0	0
WHITE_T_X	0 ~ 4095	1281	1281	1281	1281	1281	1281	1281	1281	1281
WHITE_T_Y	0 ~ 4095	1348	1348	1348	1348	1348	1348	1348	1348	1348
COLOR_GAIN	0 ~ 255	145	145	145	145	140	150	150	145	140
INPUT_RGBGAIN		512	512	512	512	512	512	512	512	512
INPUTRGBOFFSET	0 ~ 1023	460	460	460	450	450	450	470	470	470

ITEM	Range	Component											
		480i			480p			720p			1080i		
		42SD	42HD	50HD	42SD	42HD	50HD	42SD	42HD	50HD	42SD	42HD	50HD
PATT_SEL	0 ~ 25	0	0	0	0	0	0	0	0	0	0	0	0
BLACK_TILT	0 ~ 255	120	120	140	120	130	140	120	120	140	130	140	140
BLACK_GAIN_MAX	0 ~ 1023	380	400	400	380	380	380	380	380	380	380	380	380
B_RATIO		100	120	140	130	150	140	100	100	140	100	150	140
LOWER_FUNC		3	3	3	4	4	5	3	3	5	3	3	4
UPPER_FUNC		4	5	5	3	5	5	3	5	5	3	5	5
SKIN_EN	0 ~ 1	1	1	1	1	1	1	1	1	1	1	1	1
SKIN_T_X	0 ~ 4095	1770	1775	1800	1760	1745	1760	1790	1760	1790	1790	1760	1790
SKIN_T_Y	0 ~ 4095	1680	1740	1710	1710	1760	1740	1630	1670	1650	1630	1670	1650
WHITE_EN	0 ~ 1	0	0	0	0	0	0	0	0	0	00	0	0
WHITE_T_X	0 ~ 4095	1281	1281	1281	1281	1281	1281	1281	1281	1281	1281	1281	1281
WHITE_T_Y	0 ~ 4095	1348	1348	1348	1348	1348	1348	1348	1348	1348	1348	1348	1348
COLOR_GAIN	0 ~ 255	150	150	145	145	145	140	150	145	150	150	160	150
INPUT_RGBGAIN		512	512	512	512	512	512	512	512	512	512	512	512
INPUTRGBOFFSET	0 ~ 1023	450	450	450	500	500	500	470	470	470	470	470	470

7. SOUND(STV825X)

ITEM	Range	Data
Carrier Mute		1
Stereo Pilot High		35
Stereo Pilot Low		16
SAP Pilot High		128
SAP Pilot Low		96
SQTH		112
Audio Delay(Analog)		100
Audio Delay(Digital)		60
Melody Speak Volume		8(P7/Q7), 5(C7/E7)
Melody HP Volume		3

8. Sub Micom Download

9. Checksum

10. KS1406

ITEM	Range	Data
AGC_REF[AIR]		0x50
CR_F_GAIN[AIR]		0xD0B
CR_L_GAIN[AIR]		0x24
EQ_STEP[AIR]		0x0B
PILOT_GAIN[AIR]		0x01
CR_F2_GAIN[AIR]		0x1612
AGC_REF[CABLE]		0x50
CR_F_GAIN[CABLE]		0xD0B
CR_L_GAIN[CABLE]		0x24
EQ_STEP[CABLE]		0x0B
PILOT_GAIN[CABLE]		0x01
CR_F2_GAIN[CABLE]		0x1612
PACKET_ERR_THR		0x08

11. KS1409

ITEM	Range	Data
RF_AGC_TOP		0x8A
CR_PHASE_GAIN		0x4A
CR_FREQ_GAIN		0x1010
PILOT_GAIN		0x01
AGC_REF		0x50
EQ_CTRL		0x30E
PTL_COEFF		0x23
PTL_STEP		0x5C0

12. Dynamic Contrast

ITEM	Range	Data
Dynamic CE		On
Dynamic ASL Gain	42SD:Off, 42HD/50HD:On	On/Off
LBE Y_MEAN READ		

13. EEPROM Access Count

14. PDP Option

ITEM	Range	Data
Pixel Shift Test		0
Logic D/L		off
Bright Sensor	0 ~ 1	1
Sound Output	10W/15W	10W
HDMI Input	1 ~ 2	2
Control Key Lock	0 ~ 1	0
Panel Pattern Select	0 ~ 64	0
Panel Type	read	0xXX
Panel Inch	read	xx
Resolution	read	XX
Panel Version		0x3
Logic SW Version	read	XXYYZZ
Factory Update	off/on	off
Factory Data Type	BASE/MRT/Non_MRT	BASE/MRT/Non_MRT
Panel Option		PDP_42

① PDP Cool2

ITEM	Range	RF/AV			HDMI/DTV			Component			PC		
		42SD	42HD	50HD	42SD	42HD	50HD	42SD	42HD	50HD	42SD	42HD	50HD
[Cool2]R Cutoff	0 ~ 255	128	128	128	128	128	128	128	128	128	128	128	128
[Cool2]G Cutoff	0 ~ 255	128	128	128	128	128	128	128	128	128	128	128	128
[Cool2]B Cutoff	0 ~ 255	128	128	128	128	128	128	128	128	128	128	128	128
[Cool2]R Gain	0 ~ 255	128	128	128	128	128	128	128	128	128	128	128	128
[Cool2]G Gain	0 ~ 255	128	128	128	128	128	128	128	128	128	128	128	128
[Cool2]B Gain	0 ~ 255	128	128	128	128	128	128	128	128	128	128	128	128

② PDP Cool1

ITEM	Range	RF/AV			HDMI/DTV			Component			PC		
		42SD	42HD	50HD	42SD	42HD	50HD	42SD	42HD	50HD	42SD	42HD	50HD
[Cool1]R Cutoff	0 ~ 255	128	128	125	128	128	128	126	128	128	128	128	128
[Cool1]G Cutoff	0 ~ 255	128	128	125	128	128	128	128	128	128	128	128	128
[Cool1]B Cutoff	0 ~ 255	128	128	140	128	128	128	128	120	128	128	128	128
[Cool1]R Gain	0 ~ 255	128	128	128	128	128	128	128	128	128	128	128	128
[Cool1]G Gain	0 ~ 255	128	128	128	128	128	128	128	128	128	128	128	128
[Cool1]B Gain	0 ~ 255	129	132	128	128	128	128	125	128	125	128	128	128

③ PDP Normal

ITEM	Range	RF/AV			HDMI/DTV			Component			PC		
		42SD	42HD	50HD	42SD	42HD	50HD	42SD	42HD	50HD	42SD	42HD	50HD
[Normal]R Cutoff	0 ~ 255	128	128	128	128	128	128	128	128	128	128	128	128
[Normal]G Cutoff	0 ~ 255	128	128	128	128	128	128	128	128	128	128	128	128
[Normal]B Cutoff	0 ~ 255	128	128	128	128	128	128	128	128	128	128	128	128
[Normal]R Gain	0 ~ 255	128	128	128	128	128	128	128	128	128	128	128	128
[Normal]G Gain	0 ~ 255	128	128	128	128	128	128	128	128	128	128	128	128
[Normal]B Gain	0 ~ 255	128	128	128	128	128	128	128	128	128	128	128	128

④ PDP Warm1

ITEM	Range	RF/AV			HDMI/DTV			Component			PC		
		42SD	42HD	50HD	42SD	42HD	50HD	42SD	42HD	50HD	42SD	42HD	50HD
[Warm1]R Cutoff	0 ~ 255	128	128	128	128	128	128	128	128	128	128	128	128
[Warm1]G Cutoff	0 ~ 255	128	128	128	128	128	128	128	128	128	128	128	128
[Warm1]B Cutoff	0 ~ 255	128	128	128	128	128	128	128	128	128	128	128	128
[Warm1]R Gain	0 ~ 255	128	128	128	128	128	128	128	128	128	128	128	128
[Warm1]G Gain	0 ~ 255	128	128	128	128	128	128	128	128	128	128	128	128
[Warm1]B Gain	0 ~ 255	128	128	128	128	128	128	128	128	128	128	128	128

⑤ PDP Warm2

ITEM	Range	RF/AV			HDMI/DTV			Component			PC		
		42SD	42HD	50HD	42SD	42HD	50HD	42SD	42HD	50HD	42SD	42HD	50HD
[Warm2]R Cutoff	0 ~ 255	128	128	128	128	128	128	128	128	128	128	128	128
[Warm2]G Cutoff	0 ~ 255	128	128	128	128	128	128	128	128	128	128	128	128
[Warm2]B Cutoff	0 ~ 255	128	128	128	128	128	128	128	128	128	128	128	128
[Warm2]R Gain	0 ~ 255	128	128	128	128	128	128	128	128	128	128	128	128
[Warm2]G Gain	0 ~ 255	128	128	128	128	128	128	128	128	128	128	128	128
[Warm2]B Gain	0 ~ 255	128	128	128	128	128	128	128	128	128	128	128	128

- The united code option contents

	Option	Position	Option
Vol	Melody Speak Volume option	SOUND(STV825X)	P7/Q7 : 8, C7/E7 : 5
B/S	Bright Sensor option	PDP Option	P7/Q7/C7 : On, E7 : Off
10W	Sound Output option	PDP Option	P7 : 15W, Q7/C7/E7 : 10W
KR_MRT	Factory Data Type option	PDP Option	US_Mesh/KR_MRT/KR_Mesh/US_Spu

3-4 Service Adjustment

You must perform Calibration in the Lattice Pattern before adjusting the White Balance

3-4-1 Color Calibration

Adjust spec.

1. Source : HDMI
2. Setting Mode : 1280*720@60Hz
3. Pattern : Pattern #24 (Chess Pattern)

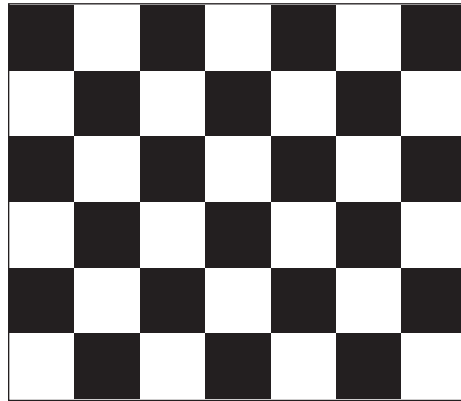

(Chess Pattern)

4. Use Equipment : CA210 & Master MSPG925 Generator

※ Use other equipment only after comparing the result with that of the Master equipment.

Input mode	Calibration	Pattern
CVBS IN (Model_#1)	Perform in NTSC B&W Pattern #24	Lattice
Component IN (Model_#6)	Perform in 720p B&W Pattern #24	Lattice
PC Analog IN (Model_#21)	Perform in VESA XGA (1024x768) B&W Pattern #24	Lattice
HDMI IN	Perform in 720p B&W Pattern #24	Lattice

<Table 1>

■ Method of Color Calibration (AV)

- 1) Apply the NTSC Lattice (NO. 3) pattern signal to the AV IN 1 port
- 2) Press the Source key to switch to "AV1" mode
- 3) Enter Service mode
- 4) Select the "Calibration" menu
- 5) Select the "AV Calibration" menu.
- 6) In "AV Calibration Off" status, press the "▶" key to perform Calibration.
- 7) When Calibration is complete, it returns to the high-level menu.
- 8) You can see the change of the "AV Calibration" status from Failure to Success.

■ Method of Color Calibration (Component)

- 1) Apply the 720p Lattice (NO. 6) pattern signal to the Component IN 1 port
- 2) Press the Source key to switch to "Component1" mode
- 3) Enter Service mode
- 4) Select the "Calibration" menu
- 5) Select the "Comp Calibration" menu.
- 6) In "Comp Calibration Off" status, press the "▶" key to perform Calibration.
- 7) When Calibration is complete, it returns to the high-level menu.
- 8) You can see the change of the "Comp Calibration" status from Failure to Success.

■ Method of Color Calibration (PC)

- 1) Apply the VESA XGA Lattice (NO. 21) pattern signal to the PC IN port
- 2) Press the Source key to switch to "PC" mode
- 3) Enter Service mode
- 4) Select the "Calibration" menu
- 5) Select the "PC Calibration" menu.
- 6) In "PC Calibration Off" status, press the "▶" key to perform Calibration.
- 7) When Calibration is complete, it returns to the high-level menu.
- 8) You can see the change of the "PC Calibration" status from Failure to Success.

■ Method of Color Calibration (HDMI)

- 1) Apply the 720p Lattice (NO. 6) pattern signal to the HDMI1/DVI IN port
- 2) Press the Source key to switch to "HDMI1" mode
- 3) Enter Service mode
- 4) Select the "Calibration" menu
- 5) Select the "HDMI Calibration" menu.
- 6) In "HDMI Calibration Off" status, press the "▶" key to perform Calibration.
- 7) When Calibration is complete, it returns to the high-level menu.
- 8) You can see the change of the "HDMI Calibration" status from Failure to Success.

3-4-2 White Balance

Adjust spec.

1. Source : HDMI
2. Setting Mode : 1280*720@60Hz
3. Pattern : Pattern #92
4. Use Equipment : MIK-7256 (MSPG925L)

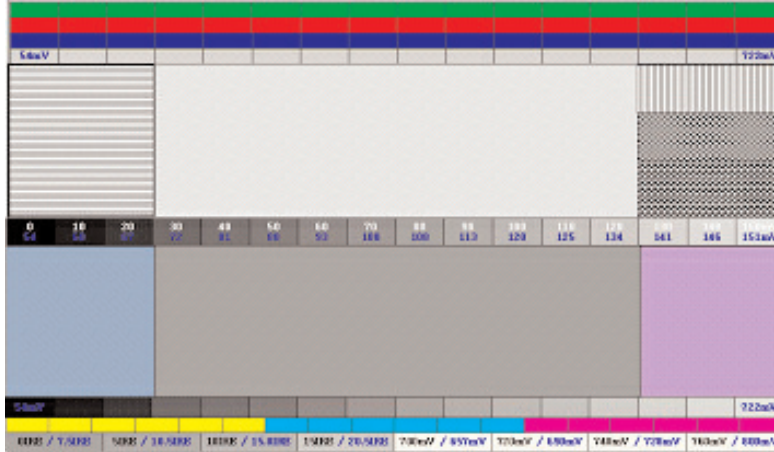

(SAMSUNG WHITE BALANCE Adjustment PATTERN with FPD)

5. Work order

- ① Connect HDMI (DVI) output terminal of MIK-7256 (MSPG925L) to the HDMI input in main set
- ② Set the input to HDMI mode
- ③ Enter the White Balance menu of service mode
- ④ Contact CA-210 sensor to glass filter

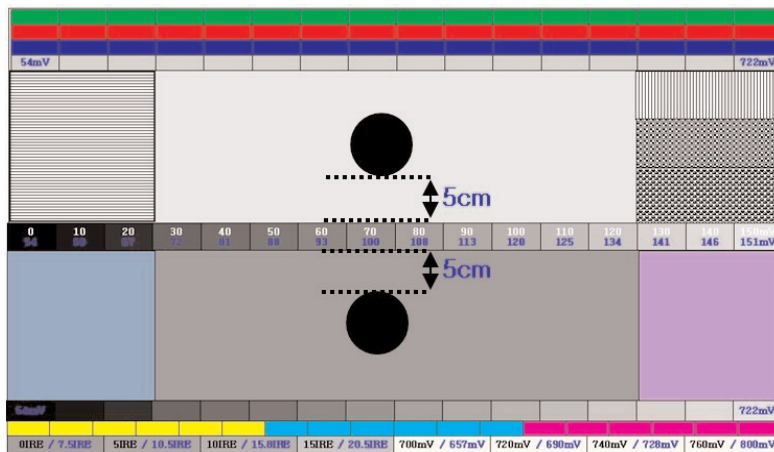

(Fixed Position of CA210 Probe)

- ⑤ Adjust the low light
 - Adjust Sub-Bright (LBE) to set the 'Y' value
 - Adjust R-Offset ('x') and B-Offset ('y') to the color coordinates.
 - * Do not adjust G-Offset data
- ⑥ Adjust the high light.
 - Adjust Sub-Contrast (LBE) to set the 'Y' value
 - Adjust R-Gain ('x') and B-Gain ('y') to the color coordinates.
 - * Do not adjust the G-gain data

Input mode		(CA-210)			
		x	y	Y(L)	T(K), MPCD
CVBS (NTSC-J)	H/L	278±3	285±3	22fL(20fL↑)	10,500 (±0)
	L/L	278±5	285±5	1.0fL±0.3fL	10,500 (±0)
COMP (720P)	H/L	278±3	285±3	23fL(20fL↑)	10,500 (±0)
	L/L	278±5	285±5	1.3fL±0.2fL	10,500 (±0)
HDMI (720P)	H/L	278±3	285±3	23fL(20fL↑)	10,500 (±0)
	L/L	278±5	285±5	1.2fL±0.1fL	10,500 (±0)
PC (XGA) (1024*768)	H/L	279±5	294±5	21fL(20fL↑)	-
	L/L	287±5	297±5	0.8fL±0.2fL	-

3-5 Software Upgrade

3-5-1 USB Download Method



1. USB Memory Stick Path

Save as CADILLAC/USA/T-CADINUS0H/appl.rom

* Some of the USB Memory Sticks can be incompatible.

2. USB Download

- 1) Insert the USB Memory Stick to the rear SERVICE 1 port in Stand-by mode.
- 2) Turn the power on.
- 3) The blank screen is displayed for about one minute.
- 4) The Power is on again and picture appears.
- 5) Disconnect the power cord and connect again, then check the software version.

* Do not unplug the power cord in the step 3.

3-5-2 How to Check the Version of the Program

1. Procedures for checking in the User Menu

- Select the "Setup" menu in the Menu screen
- Place the cursor over the "On" of "Function Help", and press the "Info" key on the remote control
- The version of the program is displayed at the bottom of the Menu screen

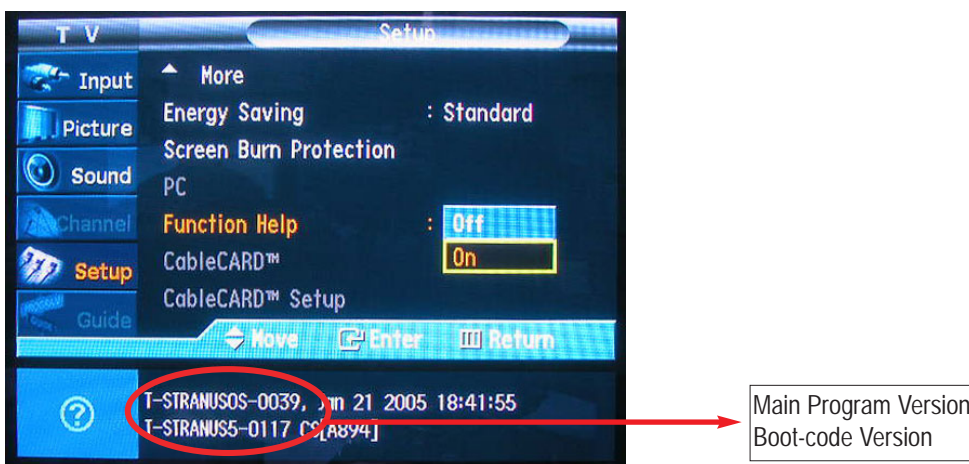

2. Procedures for checking in the Factory Menu

When entering Factory Mode, the version of the software is displayed at the bottom of the menu as described on page 3-2.

3-6 Replacements & Calibration

※ The ASS'Y code can be changed, see "5 Chapter. Electrical Part List."

* Check items listed after changing each

Replaced Items	Code No.	Check Items
ASSY PCB MISC-MAIN	BN94-00859B	1) Auto Program 2) White Balance Adjust
ASSY PCB P-SMPS(MAIN)	BN96-03252A	Vs, Va voltage check and adjust
ASSY PCB P-SMPS(DC DC)	BN96-01856A	Vscan, Vset, Ve voltage check and adjust
ASSY PDP P-LOGIC BOARD	BN96-03355A	Not adjustment
ASSY PDP P-X MAIN BOARD	BN96-03350A	
ASSY PDP P-Y MAIN BOARD	BN96-03351A	
ASSY PDP P-Y MAIN SCAN BOARD	BN96-03352A	
ASSY PDP P-ADDRESS E BUFF BOARD	BN96-03353A	
ASSY PDP P-ADDRESS F BUFF BOARD	BN96-03354A	

※ When replacing the SMPS (DC DC) or PDP panel, you have to check the voltage printed on the panel sticker and adjust it.

3-6-1 Voltage Adjustment

1. After replacing the SMPS or PDP panel, you must adjust the voltage referring to the voltage label printed on the panel.
(If you do not adjust the voltage, an abnormal discharge symptom may appear.)

	Value	Board Adjustment
Vs	200	SMPS-MAIN
Va	65	
Vset	195	SMPS-DC/DC
Ve	120	
Vscan	-190	

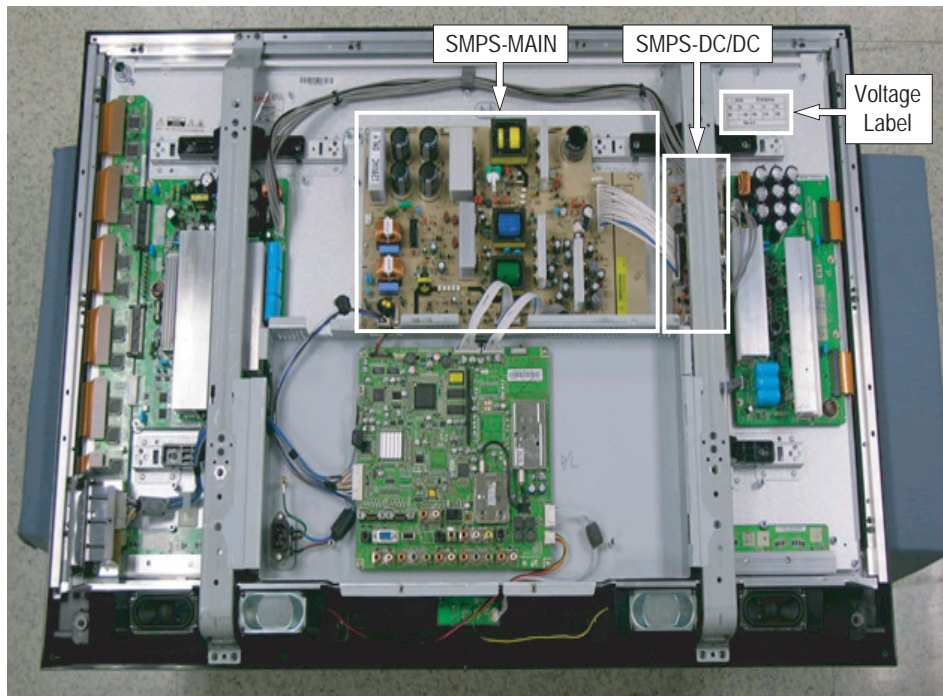

2. A point of adjusting SMPS-MAIN voltage.

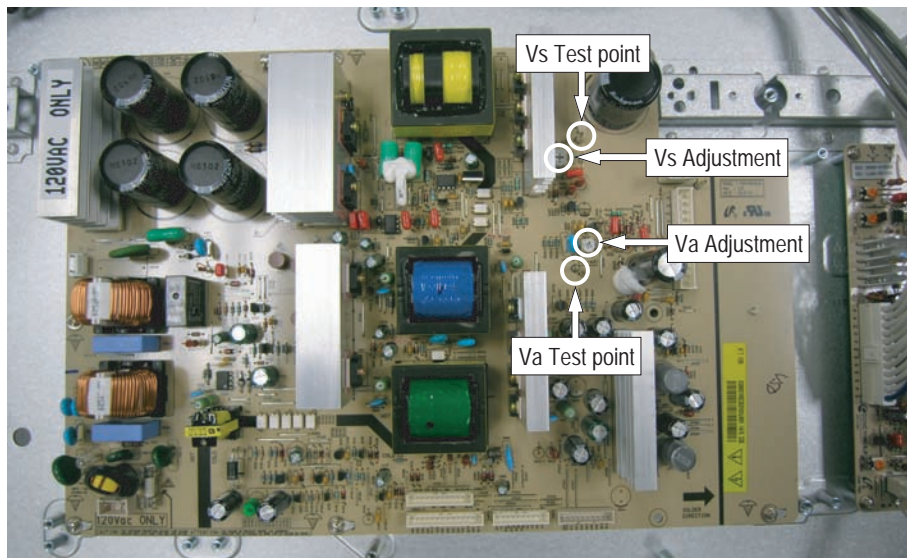

3. A point of adjusting SMPS-DC/DC.

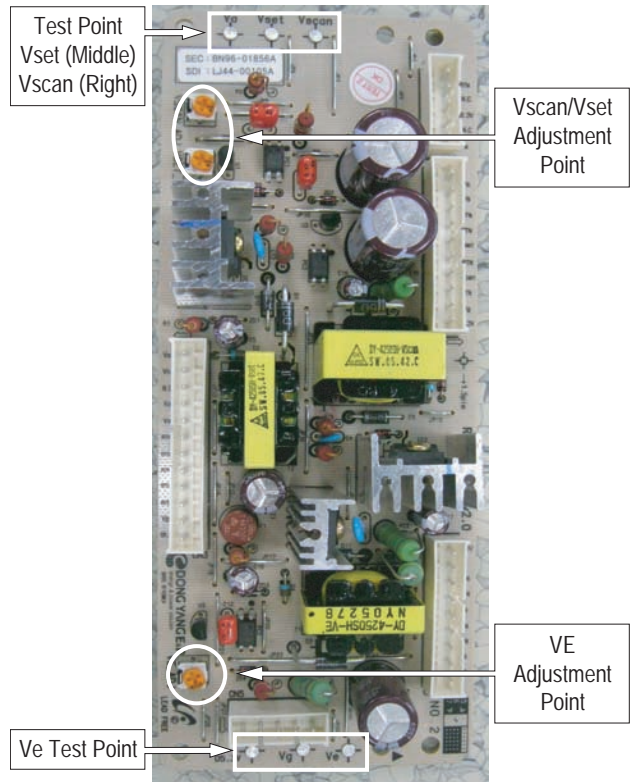

* Use base chassis of PDP panel as GND point.

3-6-2 Y-RR and Y-FR controls

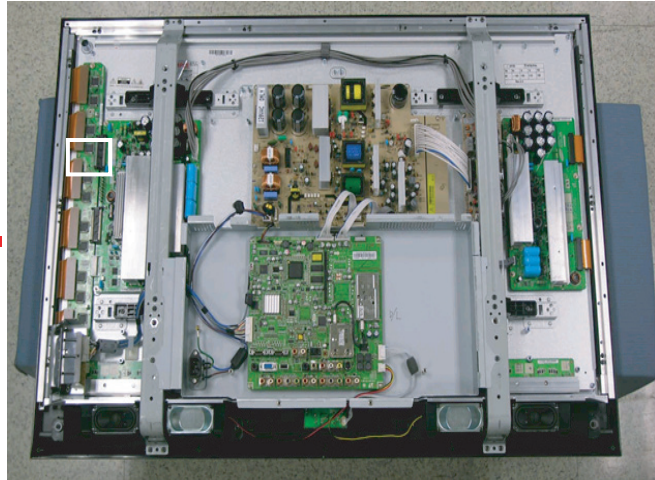
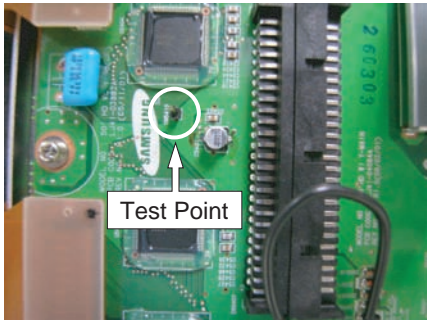

Set the main reset (rising : 60usec, falling : 80usec) by change the value of variable resistor.

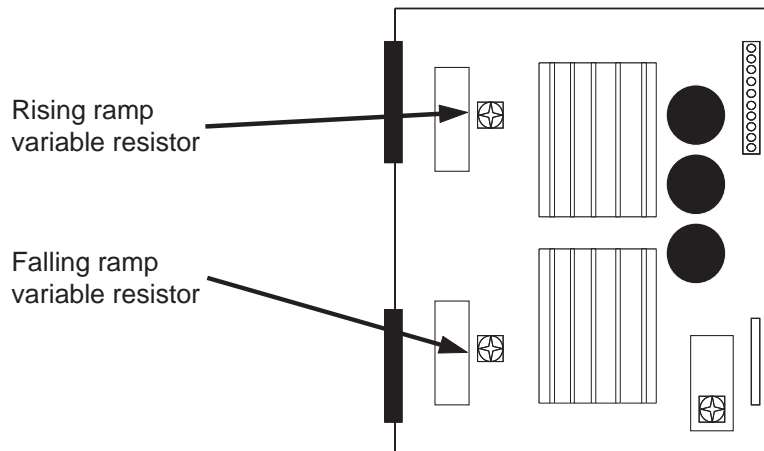
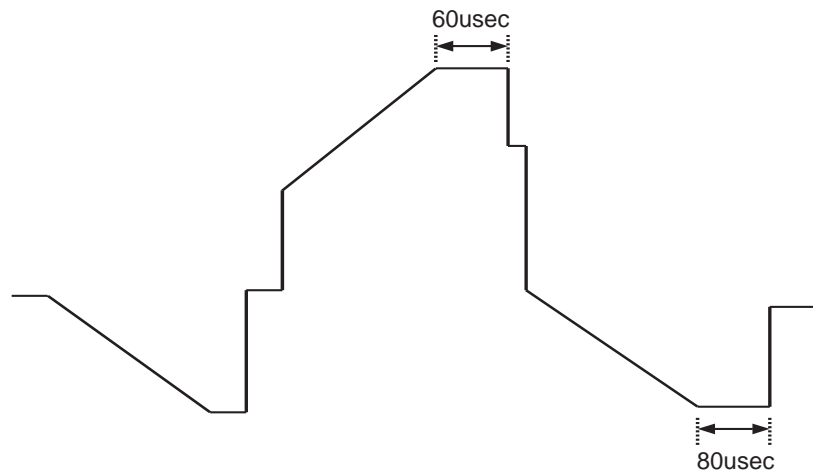

MEMO

4. Exploded View & Part List

4-1 HPS4253X/XAA

You can search for the updated part code through ITSELF web site.

URL: <http://itself.sec.samsung.co.kr>

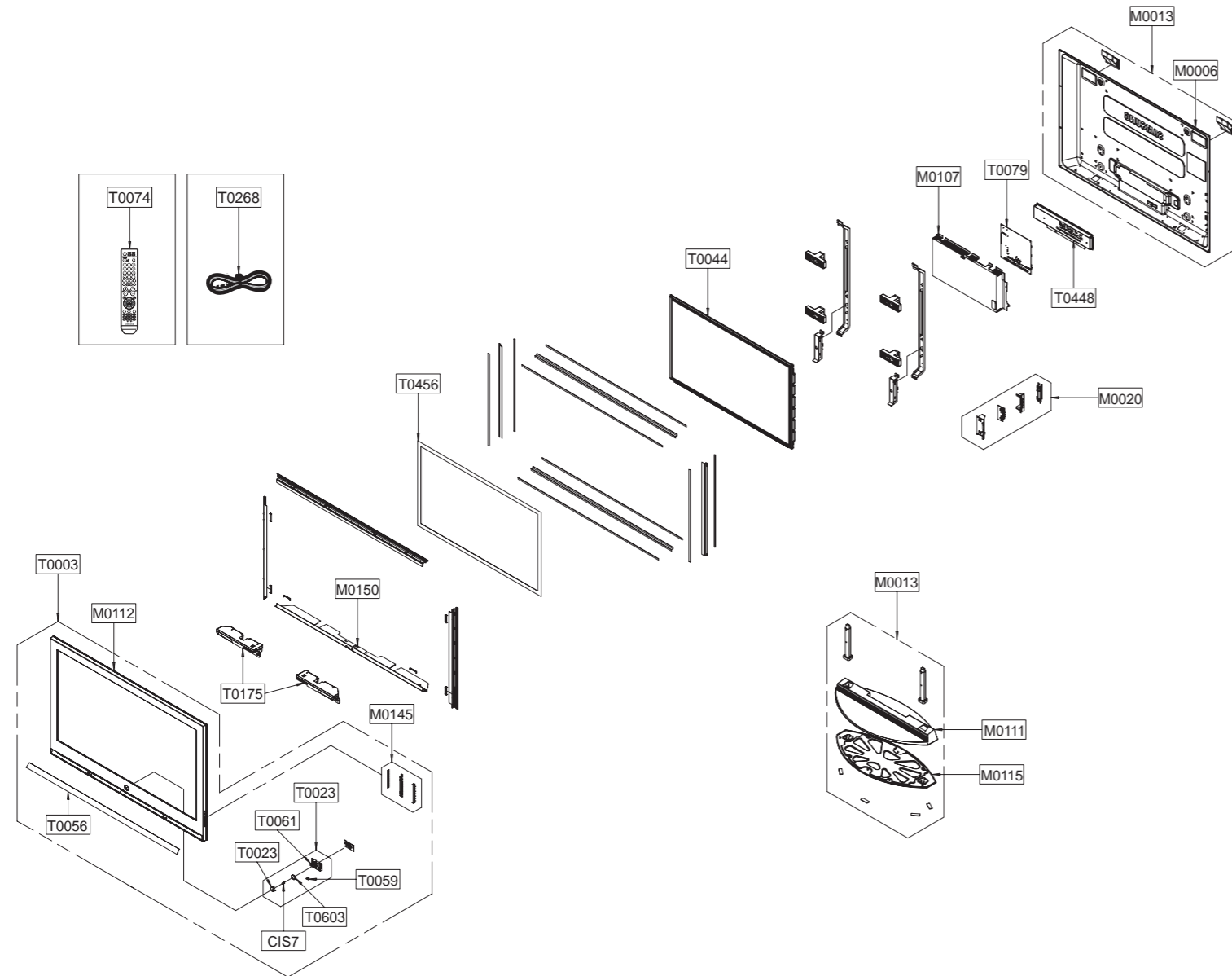

Loc. No.	Code No.	Description	Specification	Q'ty	SA/SNA	Remark
CIS7	AA61-60003B	SPRING ETC-CS	-,SUS304,-,-,OD11.2,N7,OD1	1	S.N.A	
M0006	BN63-02383A	COVER-REAR	42C7,PCM,0.5	1	S.N.A	
M0013	BN96-03154A	ASSY STAND P-BASE	Q7,HGI T3.0,BK23,Round	1	S.A	
M0013	BN96-03160A	ASSY COVER P-REAR	42C7,P7,PCM T0.5	1	S.A	
M0020	BN96-03075E	ASSY BOARD P-SIDE AV	CADILLAC,SJ06-01-00	1	S.A	
M0107	BN61-02315B	BRACKET-PCB	42C7,SECC,0.8	1	S.N.A	
M0111	BN63-02564A	COVER-STAND	Q7,ABS,HB,SF0507,BK23	1	S.N.A	
M0112	BN63-02374A	COVER-FRONT	42Q7/P7,ABS,T3.5,HB,BK23	1	S.N.A	
M0115	BN61-02338A	BRACKET-STAND	42C7,SECC,3.0	1	S.N.A	
M0145	BN96-02784B	ASSY BOARD P-FUNCTION	CADILLAC,SJ06-01-0	1	S.A	
M0150	BN96-03947A	ASSY BRACKET P-FILTER BOTTOM	42Q7/P7,AL,	1	S.N.A	
T0003	BN96-03951A	ASSY COVER P-FRONT	42Q7(HQ),ABS,HB,BK23,	1	S.N.A	
T0023	BN96-03173A	ASSY COVER P-KNOB POWER	42P7,ABS	1	S.N.A	
T0023	BN64-00459A	KNOB POWER	42P7,PC,Violet	1	S.N.A	
T0044	BN96-03288A	ASSY PDP MODULE P	M1,42HD,V5.1,1024*768,	1	S.A	
T0056	BN63-02386A	COVER-DECORATION	42Q7,PC SHEET,T0.5,Silv	1	S.N.A	
T0059	BN64-00461A	INDICATOR LED	42P7,PMMA	1	S.N.A	
T0061	BN64-00462A	WINDOW-REMOCON	42P7,ACRYL,5%	1	S.N.A	
T0074	BN59-00511A	REMOCON	Bordeaux,TM87B,SAMSUNG 28P+EEPRO	1	S.A	
T0079	BN94-00859B	ASSY PCB MISC-MAIN	HP-S4253,CADILLAC,BN4	1	S.A	
T0175	BN96-03392A	ASSY SPEAKER P	8ohm,Q7,10W,2Way,2speaker	1	S.A	
T0268	3903-000144	CBF-POWER CORD	DT,US,BP3/Y,U(IEC C13-RA)	1	S.A	
T0448	BN96-03144A	ASSY BRACKET P-TERMINAL	42C7,P7,SECC T0.	1	S.N.A	
T0456	BN67-00172A	GLASS-FILTER EMI	42" Q7, C7 No B/C,Mesh,	1	S.A	
T0603	BN64-00460A	KNOB-DECORATION POWER	42P7,ABS,HB,AL	1	S.N.A	

5. Electrical Part List

5-1 HPS4253X/XAA Service Item

You can search for the updated part code through ITSELF web site.

URL:<http://itself.sec.samsung.co.kr>

Loc. No.	Code No.	Description	Specification	Q'ty	SA/SNA	Remark
M0013	BN96-03154A	ASSY STAND P-BASE	Q7,HGI T3.0,BK23,Round	1	S.A	
M0013	BN96-03160A	ASSY COVER P-REAR	42C7,P7,PCM T0.5	1	S.A	
M0018	BN97-00755A	ASSY MICOM	T-CADINUS5-1002,S3F866B,20060	1	S.A	
M2893	BN39-00632B	LEAD CONNECTOR	PS-42E7HX/XEC,UL1617#22,U	1	S.A	
M2893	BN39-00667C	LEAD CONNECTOR-LVDS	D71C/SPD-42S5HD,UL20	1	S.A	
M2893	BP39-00053D	LEAD CONNECTOR	SCHUBERT,UL1007#26,10P,15	1	S.A	
T0003	BN96-03951A	ASSY COVER P-FRONT	42Q7(HQ),ABS,HB,BK23,	1	S.A	
T0044	BN96-03288A	ASSY PDP MODULE P	M1,42HD,V5.1,1024*768,	1	S.A	
T0074	BN59-00511A	REMOCON	Bordeaux,TM87B,SAMSUNG	1	S.A	
T0079	BN94-00859B	ASSY PCB MISC-MAIN	HP-S4253,CADILLAC,BN4	1	S.A	
T0159	BN96-01856A	ASSY PCB P-SMPS	SPD-50P5HD(DC_DC),200Vin	1	S.A	
T0159	BN96-03252A	ASSY PCB P-SMPS	HPS4253,100V-120V,245*37	1	S.A	
T0175	BN96-03392A	ASSY SPEAKER P	8ohm,Q7,10W,2Way,2speaker	1	S.A	
T1910	BN96-03350A	ASSY PDP MODULE P-X MAIN BOARD	42HD,PL42	1	S.A	
T1911	BN96-03351A	ASSY PDP MODULE P-Y MAIN BOARD	42HD,PL42	1	S.A	
T1914	BN96-03353A	ASSY PDP MODULE P-ADDRESS E BU	42HD,PL42	1	S.A	
T1915	BN96-03354A	ASSY PDP MODULE P-ADDRESS F BU	42HD,PL42	1	S.A	
T1917	BN96-03355A	ASSY PDP MODULE P-LOGIC MAIN B	42HD,PL42	1	S.A	
T9698	BN96-03352A	ASSY PDP MODULE P-Y MAIN SCAN	42HD,PL42A	1	S.A	

MEMO

6. Troubleshooting

6-1 First Checklist for Troubleshooting

1. Check the various cable connections first.
 - Check to see if there is a burnt or damaged cable.
 - Check to see if there is a disconnected cable connection or a connection is too loose.
 - Check to see if the cables are connected according to the connection diagram.
2. Check the power input to the Main Board.
3. Check the voltage in and out between the SMPS ↔ Main Board, between the SMPS ↔ X, Y Main Board, and between the Logic Boards.

6-2 Checkpoints by Error Mode

6-2-1 No Power

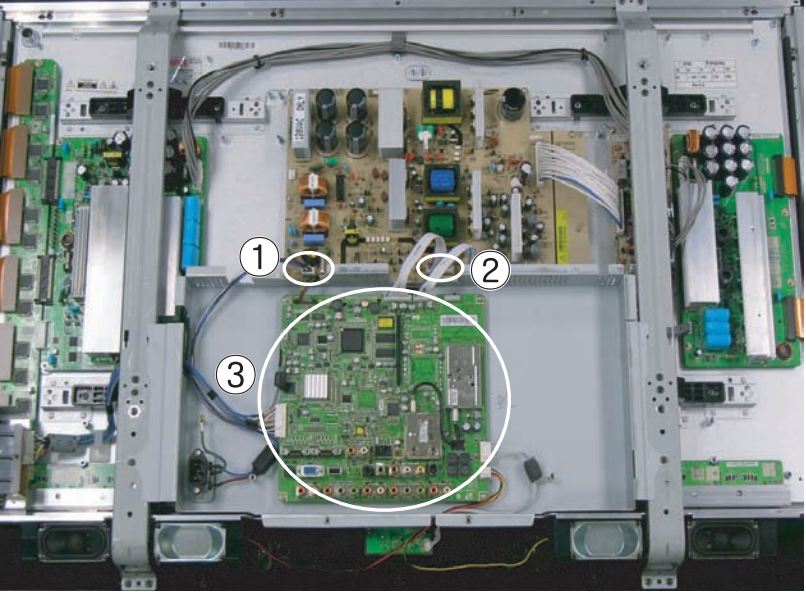
Symptom	<ul style="list-style-type: none"> - The LEDs on the front panel do not work when connecting the power cord. - The SMPS relay does not work when connecting the power cord. - The power of the unit seems to be out of order.
Major Checklist	<p>The SMPS relay or the LEDs on the front panel do not work when connecting the power cord if the cables are improperly connected or the Main Board or SMPS is out of order. In this case, check the following:</p> <ul style="list-style-type: none"> - Check the internal cable connection status inside the unit. - Check the fuses of each part. - Check the output voltage of SMPS. - Replace the Main Board.
Troubleshooting Procedures	<div style="text-align: center;">  </div> <pre> graph TD Q1["① Are the AC IN socket connector and the Main SMPS CN800 connected?"] A1["Connect The AC IN socket connector and the Main SMPS CN800"] Q2["① Is the Fuse (F101) of the Main SMPS Power Input Part blown?"] A2["Replace the Main SMPS"] Q3["② Check Main SMPS 804-1 Pin 10 : STB 5V = 5V Pin 8 : PS-ON = 0V"] A3["Replace the Main SMPS"] Q4["③ Replace the Main Board"] Q1 -- No --> A1 Q1 -- Yes --> Q2 Q2 -- No --> A2 Q2 -- Yes --> Q3 Q3 -- No --> A3 Q3 -- Yes --> Q4 </pre>

6-2-2 When the unit is repeatedly turned on and off

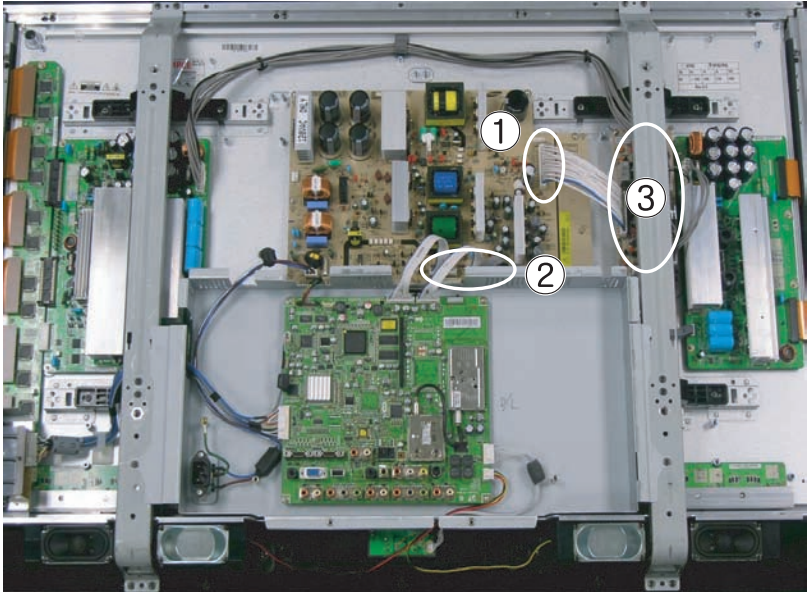
Symptom	- The SMPS relay is repeatedly turned on and off.
Major Checklist	<p>In general, the SMPS relay repeatedly turns on and off by the protection function due to a defect on a board connected to the SMPS.</p> <ul style="list-style-type: none"> - Disconnect all cables from the SMPS, operate the SMPS alone and check if the SMPS works properly and if each voltage output is correct. - If the symptom continues even when SMPS is operated alone, replace the SMPS. - If the symptom is not observed when operating the SMPS alone, find any defective ASSYs by connecting the cables one by one.
Troubleshooting Procedures	 <pre> graph TD Q1["① Does the symptom continue after connecting the power and removing CN809 cable from the Main SMPS?"] Q2["② Does the symptom continue when separating the CN804-1 and CN803 cables from the Main SMPS and shorting pins 4 and 5 of the CN804-1 Connector?"] Q3a["③ Does the symptom continue when connecting the power after connecting the CN809 cable and removing the CN2, CN4 and CN5 cables from the DC-DC SMPS?"] Q3b["③ Reconnect all cables. Does the symptom continue when connecting the power after the CN4 cable to the DC-DC SMPS?"] Q3c["③ Does the symptom continue when connecting the power after CN2 to the DC-DC SMPS?"] Q3d["② Does the symptom continue when connecting the power after removing CN810 from the Main SMPS?"] R1["Replace the DC-DC SMPS"] R2["Replace the X Main Board"] R3["Replace the Y Main Board"] R4["Replace the Logic Main Board"] Q1 -- No --> Q3a Q1 -- Yes --> Q2 Q2 -- No --> R4 Q2 -- Yes --> R5["Replace the Main SMPS"] Q3a -- No --> Q3b Q3a -- Yes --> R1 Q3b -- No --> Q3c Q3b -- Yes --> R2 Q3c -- No --> Q3d Q3c -- Yes --> R3 Q3d -- No --> R4 </pre>
Caution	When separating and connecting the cables such as CN809 of the Main SMPS, CN1, CN2, CN3, CN4 and CN5 of DC-DC SMPS, CN of the X Main Board, and CN of the Y Main Board, a spark may be generated by the electric charge of the high capacity capacitor. Therefore, wait some time after separating the power cord from the unit.

6-2-3 No Picture (When audio is normal)

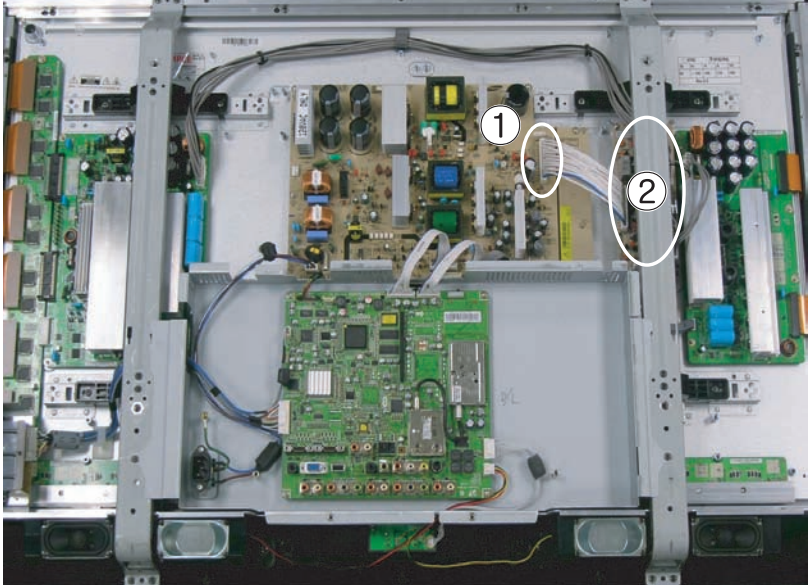
Symptom	- Audio is normal but no picture is displayed on the screen.
Major Checklist	<ul style="list-style-type: none"> - This may happen when the Main Board is normal but the X, Y Main Board, Logic Board, or Y Buffer Boards are out of order. - The output voltage of the Main SMPS or the DC-DC SMPS is out of order. - This may happen when the LVDS cable connecting the Main Board and the Logic Board is disconnected.
Troubleshooting Procedures	 <pre> graph TD Q1["① Are the Vs and Va voltages normal after removing the CN809 cable from the Main SMPS?"] R1["Replace the Main SMPS"] Q2["② Is the output voltage of the DC-DC SMPS normal when reconnecting the CN809 cable and removing the CN2, CN4 and CN5 cables from the DC-DC SMPS?"] R2["Replace the DC-DC SMPS"] R3["Replace the Y Main Board"] R4["Replace the X Main Board"] R5["Replace the Logic Main Board"] R6["Replace the Y SCAN Board"] Q1 -- No --> R1 Q1 -- Yes --> Q2 Q2 -- No --> R2 Q2 -- Yes --> R3 R3 --> R4 R4 --> R5 R5 --> R6 </pre>
Caution	When separating and connecting the cables such as CN809 of the Main SMPS, CN1, CN2, CN3, CN4 and CN5 of the DC-DC SMPS, CN of the X Main Board, and CN of the Y Main Board, a spark may be generated by the electric charge of the high capacity capacitor. Therefore, wait some time after separating the power cord from the unit.

6-2-4 No Sound

Symptom	- Video is normal but there is no sound.
Major Checklist	- When the speaker connectors are disconnected or damaged. - When the sound processing part of the Main Board is out of order. - Speaker defect.

Troubleshooting Procedures

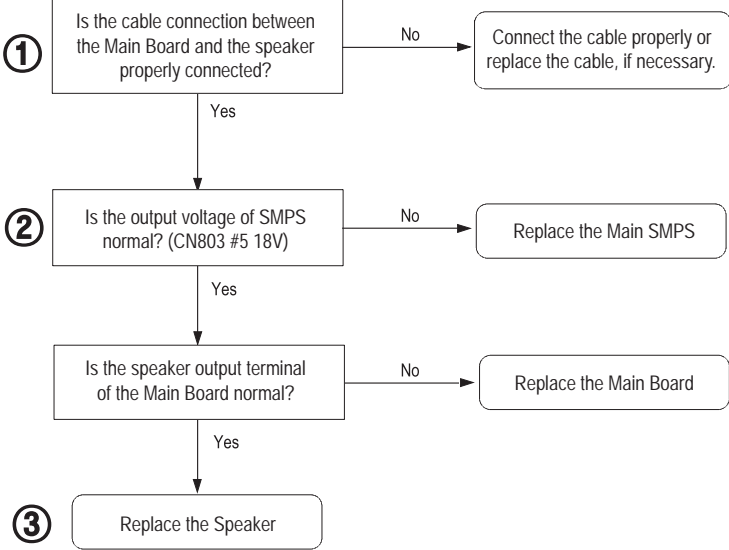
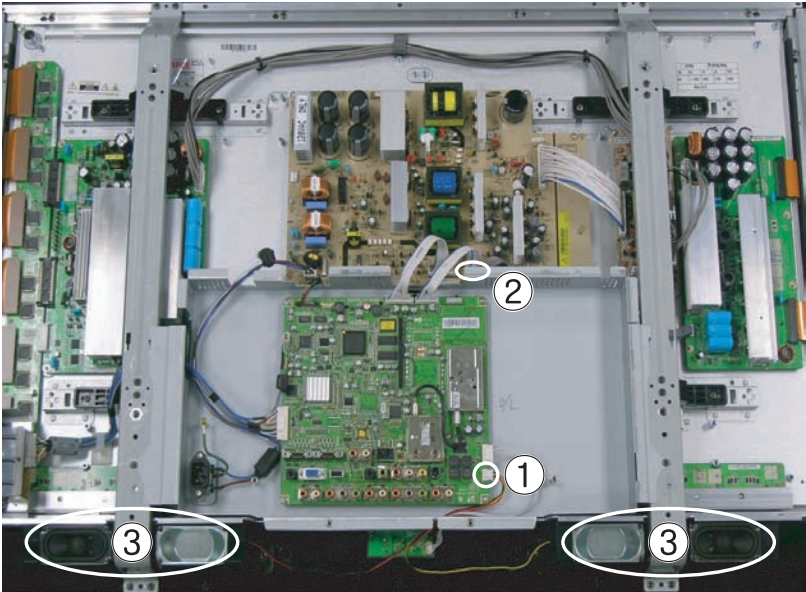

6-2-5 No Video

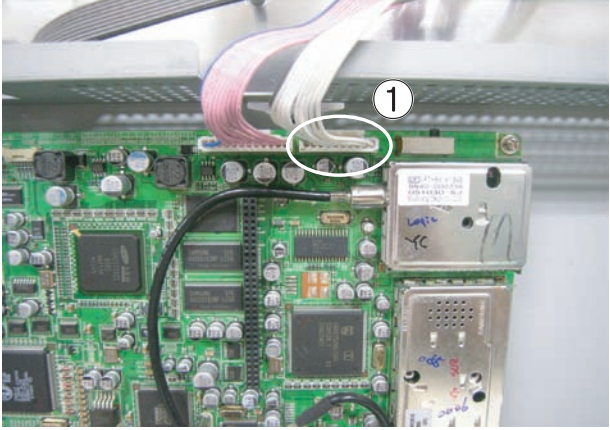
Symptom	- A normal/cable network analog broadcast screen is blank or abnormal but OSD is OK.
Major Checklist	<ul style="list-style-type: none"> - Check the antenna connection settings (Antenna 1 - Normal/Cable/DTV, Antenna 2 - Only for DTV) - Check the tuner output signal (CVBS). - Check the power input of the Main board.
Troubleshooting Procedures	<div style="text-align: center;">  </div> <pre> graph TD Q1[Is the antenna connection setting properly configured?] -- No --> A1[Configure properly] Q1 -- Yes --> Q2[1 Check CN101 pin2 for +33V] Q2 -- No --> A2[Replace the Main SMPS] Q2 -- Yes --> A3[Replace the Main Board] </pre>

6-2-6 Main SMPS Troubleshooting

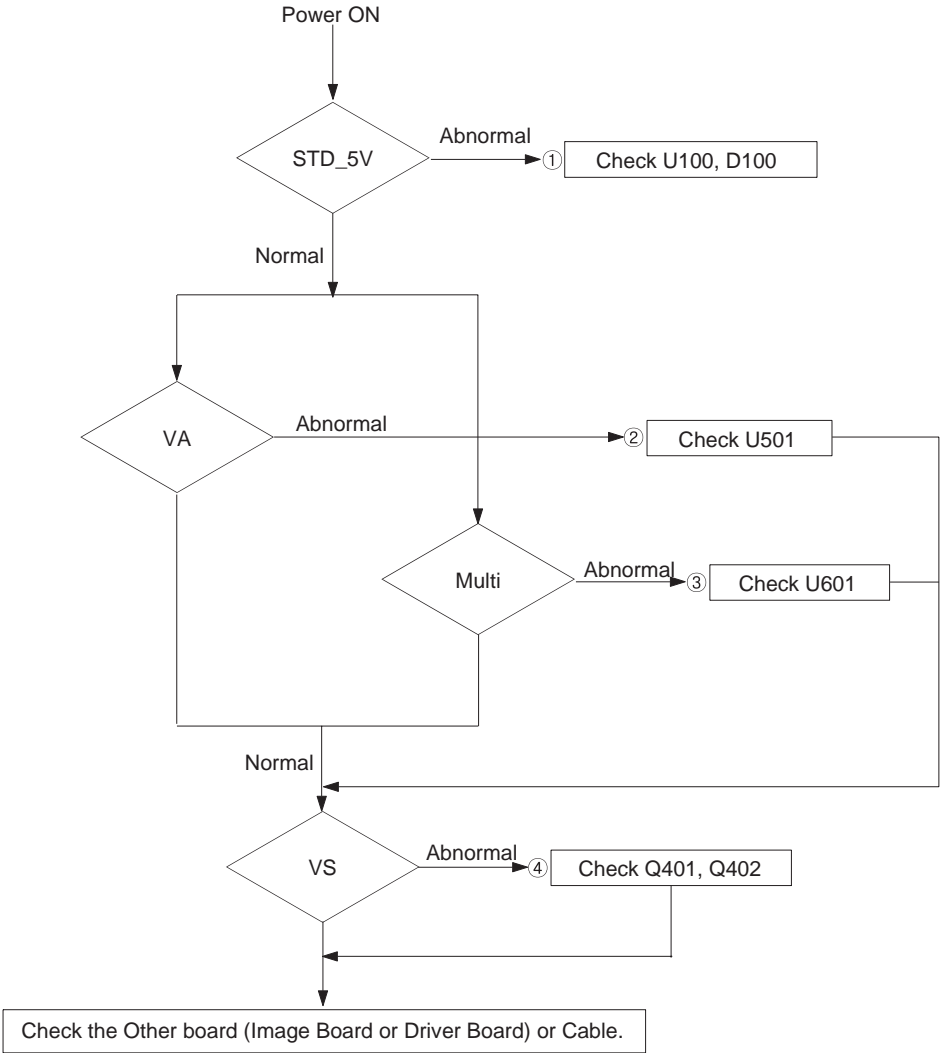

6-2-7 Drive Board Troubleshooting

1) Troubleshooting Summary

Condition Name	Description	Related Board
No Voltage Output	Operating Voltage don't exist	PSU
No Display	Operating Voltage exist, but an Image doesn't exist on screen	Y-MAIN, X-MAIN, Logic Main, Cable
Abnormal Display	Abnormal Image (not open or short) is no screen	Y-MAIN, X-MAIN, Logic Main
Sustain Open	Some horizontal lines don't exist on screen	Scan Buffer, FPC of X/Y
Sustain Short	Some horizontal lines appear to be linked on screen	Scan Buffer, FPC of X/Y
Address Open	Some vertical lines don't exist on screen	Logic Main, Logic Buffer, TCP
Address Short	Some vertical lines appear to be linked on screen	Logic Main, Logic Buffer, TCP

2) Troubleshooting Procedure in Abnormal Conditions

① No Display (Operating Voltage exist, but an doesn't exist on Screen)

► No Display is related with Y-MAIN, X-MAIN, Logic Main and so on.

This page shows you how to check the boards, and the following pages show you how to find the defective board.

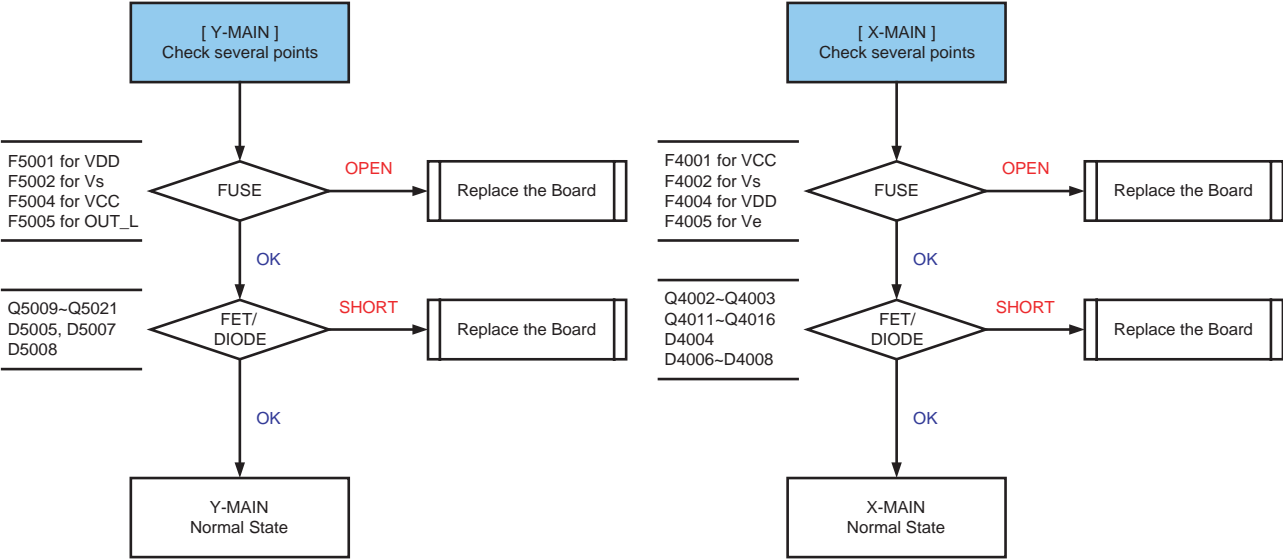
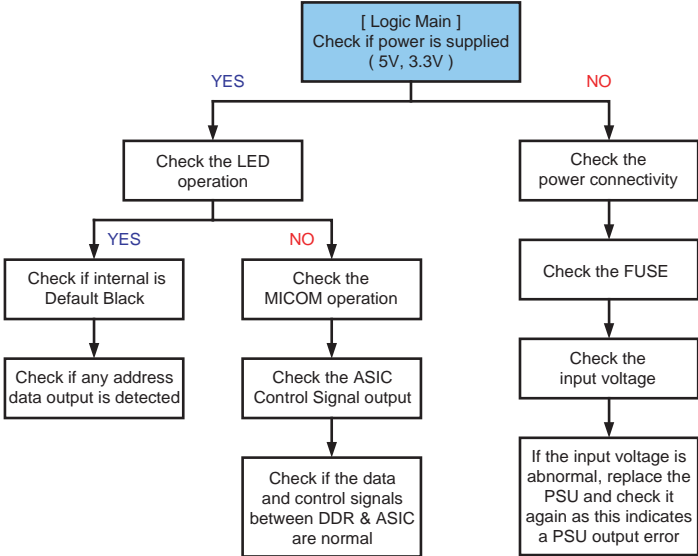
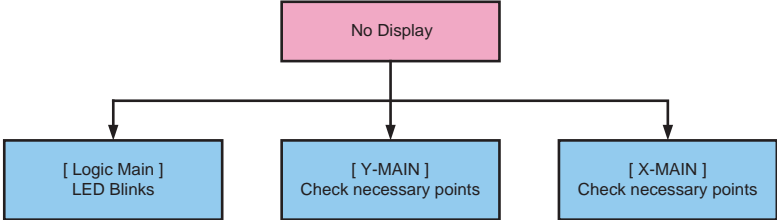

② Abnormal Display(Abnormal Image is on Screen.(except abnormality in Sustain or Address))

► Abnormal Display is related with Y-MAIN, X-MAIN, Logic Main and so on.

This page shows you how to check the boards, and the following pages show you how to find the defective board.

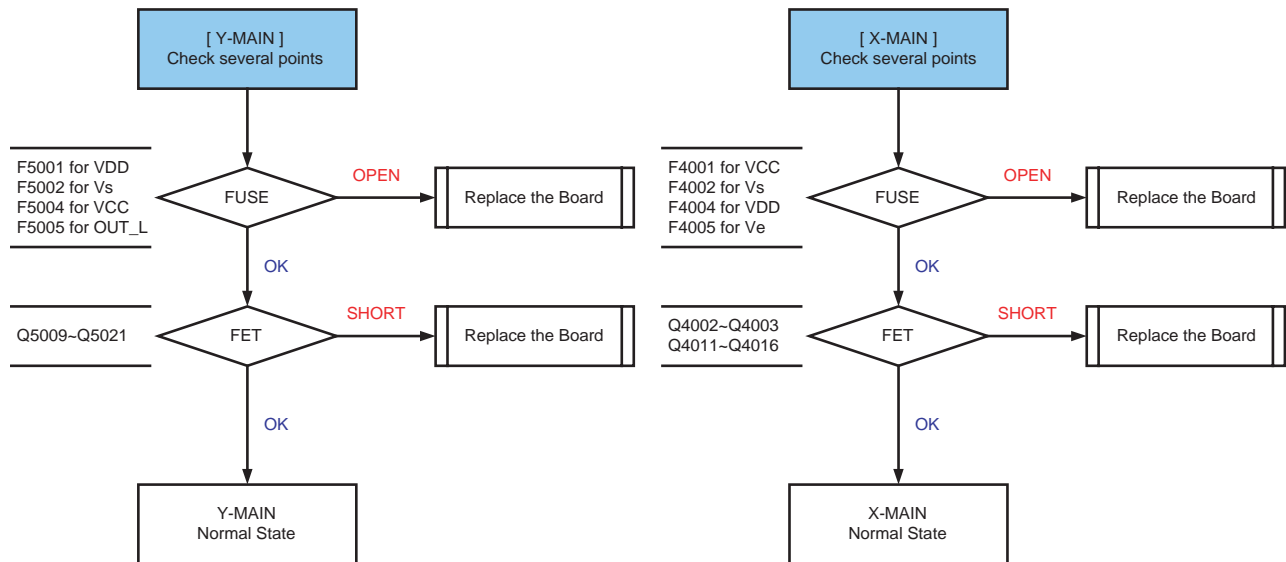
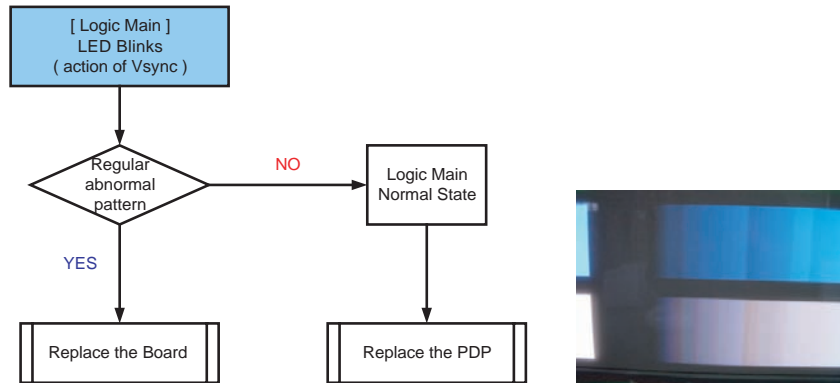
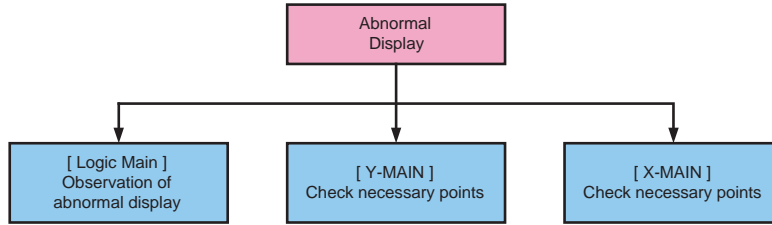

③ Sustain Open (some horizontal lines don't exist on screen)

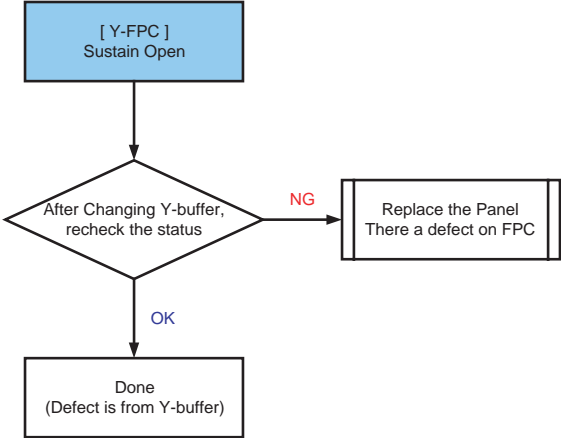

④ Sustain Short (some horizontal lines appear to be linked on Video)

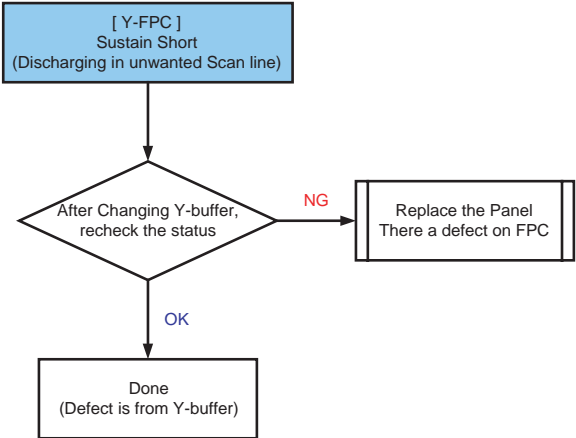

⑤ Address Open, Short(some vertical lines don't exist on screen)

▶ Address Open and Short is related with Logic Main, Logic Buffer, FFC, TCP film and so on.

This page shows you how to check the boards, and the following pages show you how to find the defective board.

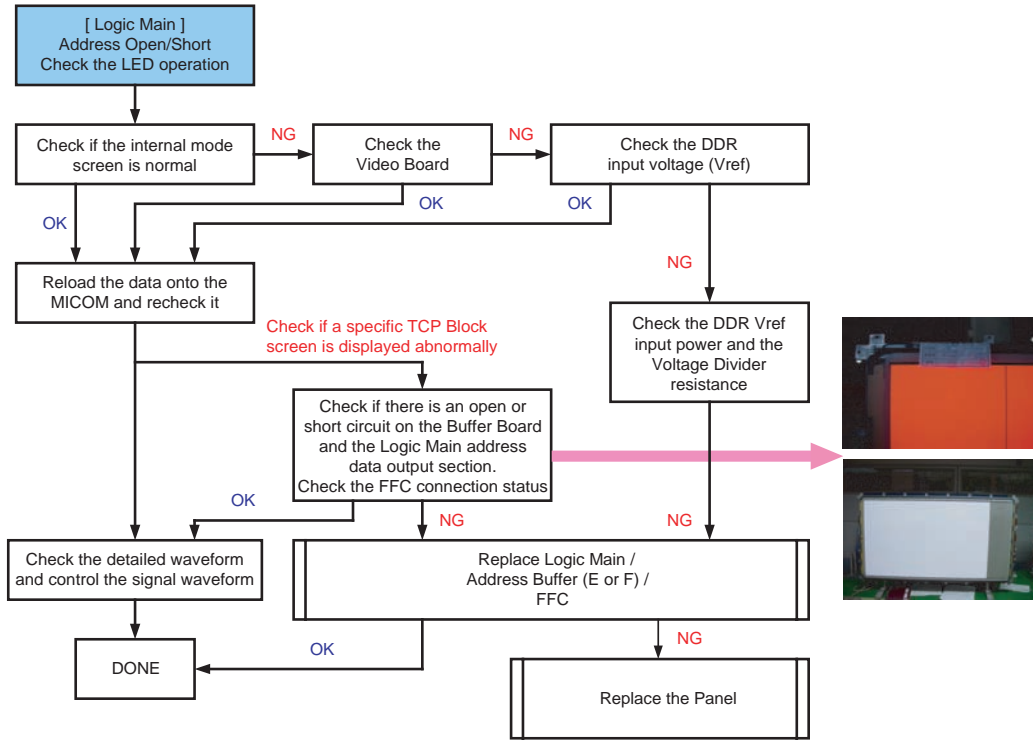

6-3 Troubleshooting Procedures by ASS'Y

※ The ASS'Y code can be changed, see "5 Chapter. Electrical Part List."

No	Assy	Code No.	Description	Major Symptoms
1	ASSY PCB P-SMPS	BN96-03252A	Main SMPS	No power, Blank screen, the Relay repeats On and Off.
2	ASSY PCB P-SMPS	BN96-01856A	DC-DC SMPS	Blank screen, the Relay repeats On and Off.
3	ASSY PDP P-X MAIN BOARD	BN96-03350A	X Main Board	Blank screen
4	ASSY PDP P-Y MAIN BOARD	BN96-03351A	Y Main Board	Blank screen
5	ASSY PDP MODULE P-LOGIC MAIN BOARD	BN96-03355A	Logic Board	Blank screen, Screen noise
6	ASSY PDP P-Y SCAN BOARD	BN96-03352A	Y Scan Board	Row Bar screen is blank
7	ASSY PDP P-ADDRESS E-BUFF BOARD	BN96-03353A	Address E Buffer Board	Corresponding Buffer Board block screen is blank.
8	ASSY PDP P-ADDRESS F-BUFF BOARD	BN96-03354A	Address F Buffer Board	Corresponding Buffer Board block screen is blank.
9	ASSY PCB MISC-MAIN	BN94-00859B	Main Board	No Power, Abnormal screen for each input source, PIP screen trouble, Sound trouble
10	ASSY BOARD P-FUNCTION	BN96-02784B	Function Key Board	The side function key does not work properly
11	ASSY BOARD P-POWER&IR	BN96-03320A	Power Button Board	The remote control does not work properly, the LED does not work properly.
12	ASSY BOARD P-SIDE AV	BN96-03075E	Side AV Board	The AV2 and S-VIDEO2 modes do not work properly

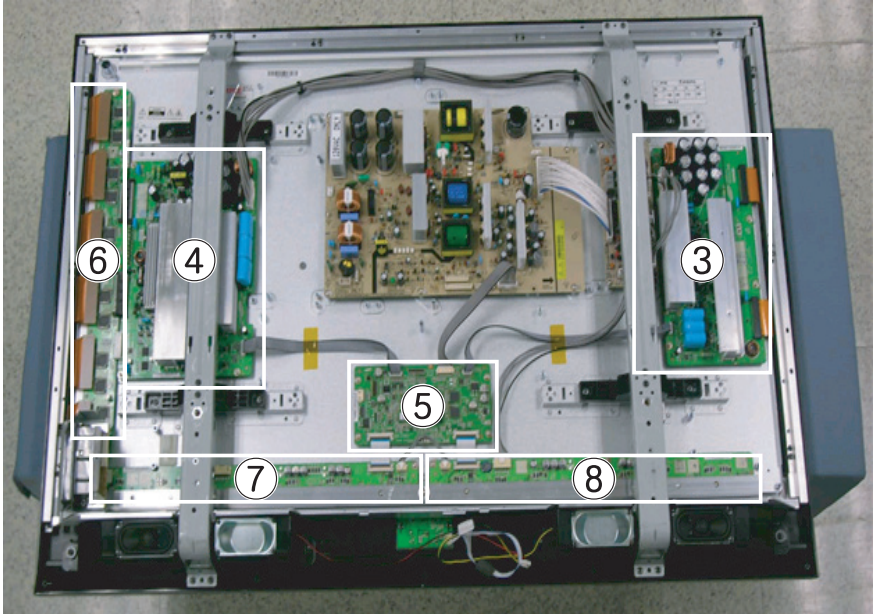
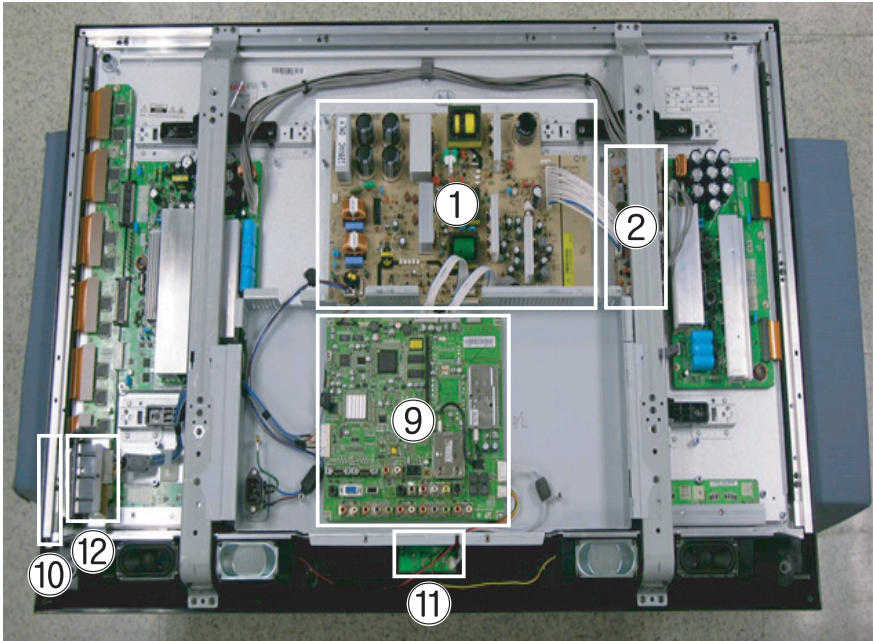

MEMO

7. Block Diagram

7-1 Overall Block Diagram

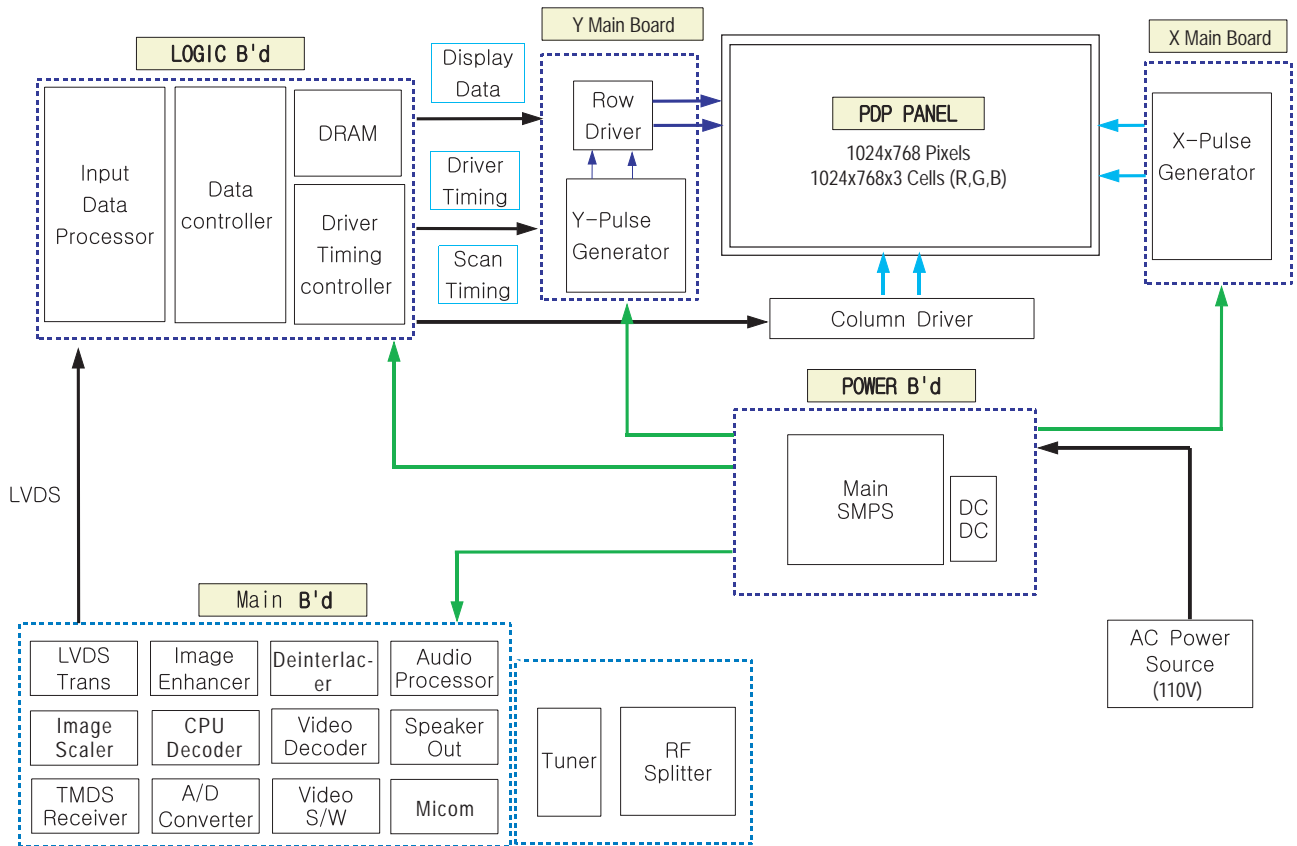

Block Diagram

CN804-1(Main SMPS) ↔ CN102(Main B'D)		CN803(Main SMPS) ↔ CN101(Main B'D)		CN810(Main SMPS) ↔ CN2085(Logic B'D)		CN2(DC-DC SMPS) ↔ CN5010(Y B'D)		CN4(DC-DC SMPS) ↔ CN4004(X B'D)	
Pin No.	Signal	Pin No.	Signal	Pin No.	Signal	Pin No.	Signal	Pin No.	Signal
1	D5.3V	1	6.5V	1	D5.3V	1	D5.3V	1	D5.3V
2	RTN	2	RTN	2	D5.3V	2	Vg	2	Vg
3	VCS	3	A12V	3	RTN	3	RTN	3	RTN
4	VCA	4	RTN	4	RTN	4	Vscan	4	RTN
5	RTN	5	18V-AMP	5	D5.3V	5	RTN	5	Ve
6	RTN	6	18V-AMP	6	RTN	6	Vset	6	RTN
7	D12V	7	RTN-AMP	7	PS_ON	7	RTN	7	RTN
8	PS_ON	8	RTN-AMP	8	N.C	8	RTN	8	Vs
9	RTN	9	VT	9	VS_ON	9	Vs	9	Vs
10	STB-5V	10	RTN	10	STB-5V	10	Vs		
11	FAN_ON								
12	FAN_D								

CN5(DC-DC SMPS) ↔ CN2710(F-Buffer)	
Pin No.	Signal
1	RTN
2	N.C
3	D5.3V
4	N.C
5	Va

7-2 Partial Block Diagram

7-2-1 Main SMPS Block Diagram

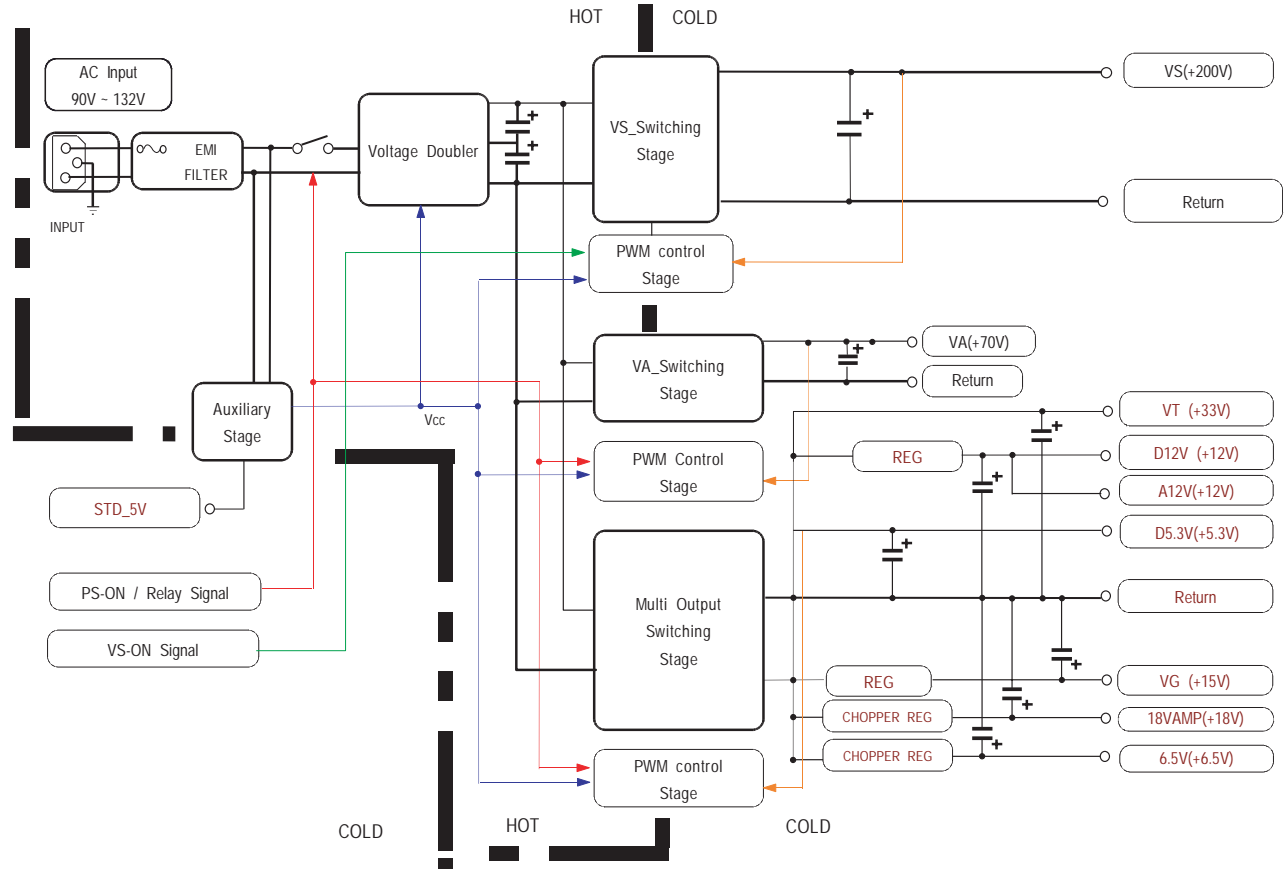

7-2-2 DC-DC SMPS Block Diagram

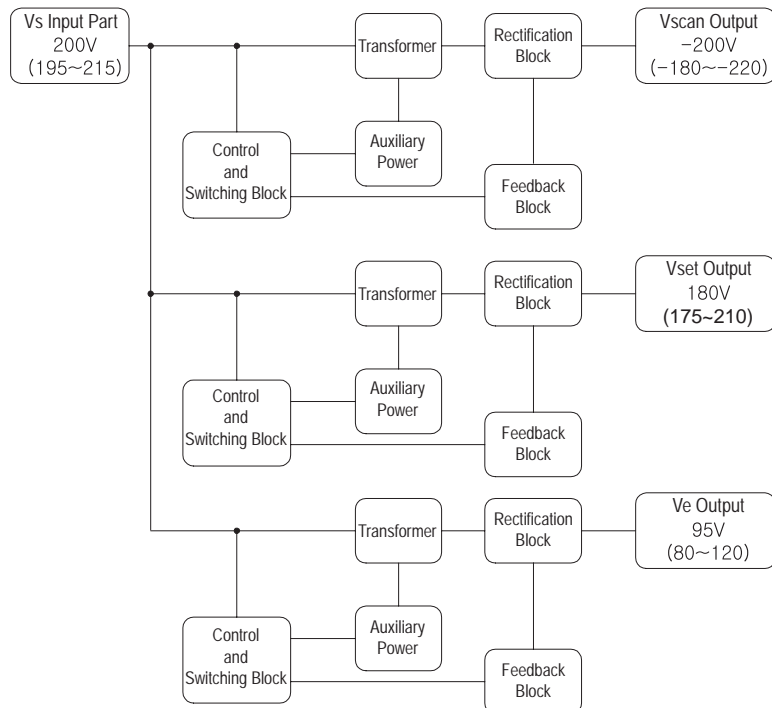

7-2-3 Module Driver Board Block Diagram

1. Y Main Board

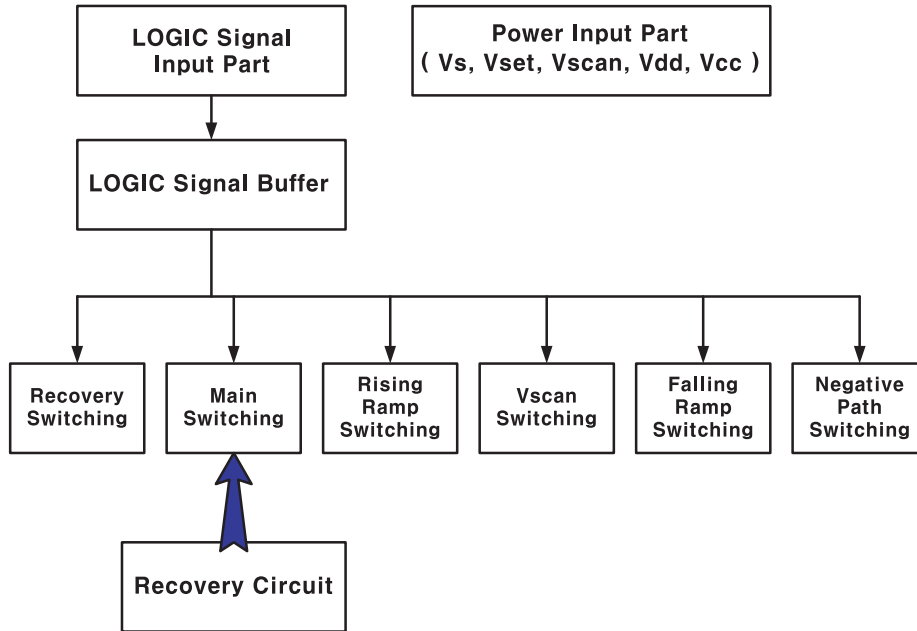

2. X Main Board

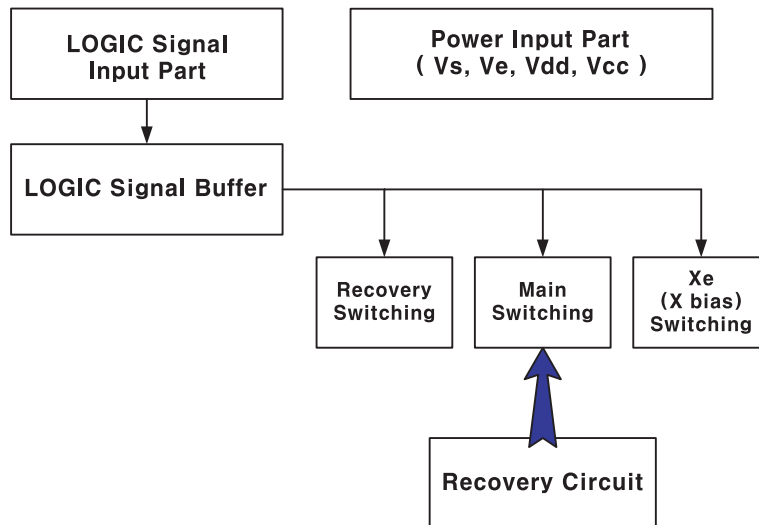

7-2-4 Logic Board Block Diagram

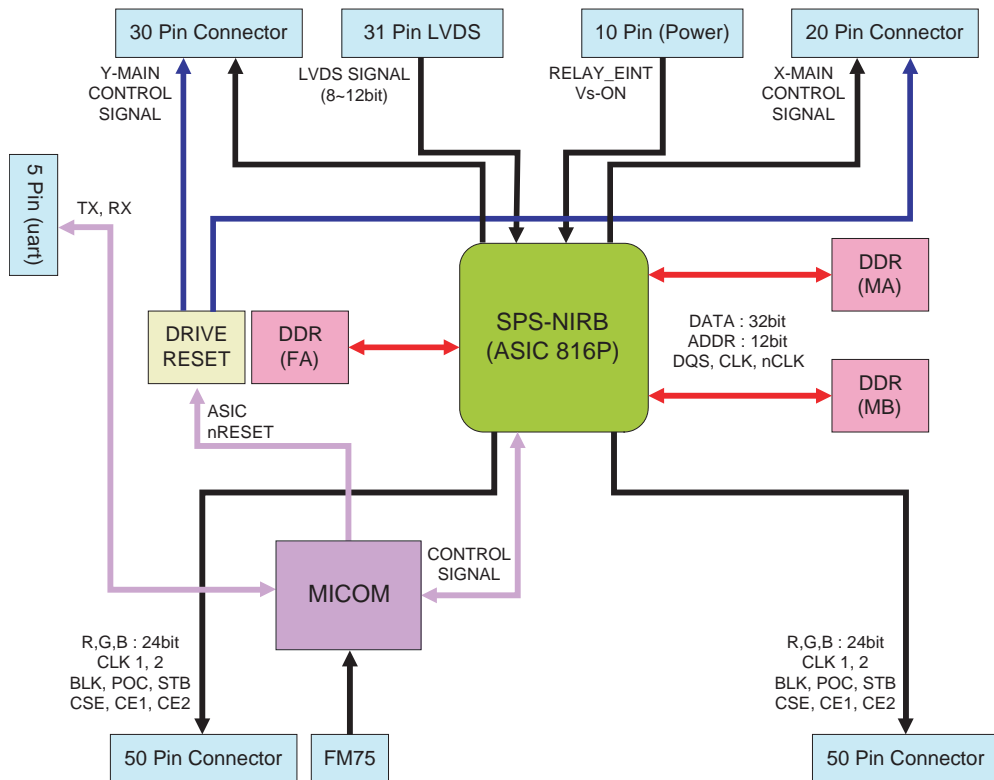

7-2-5 Main Board Block Diagram

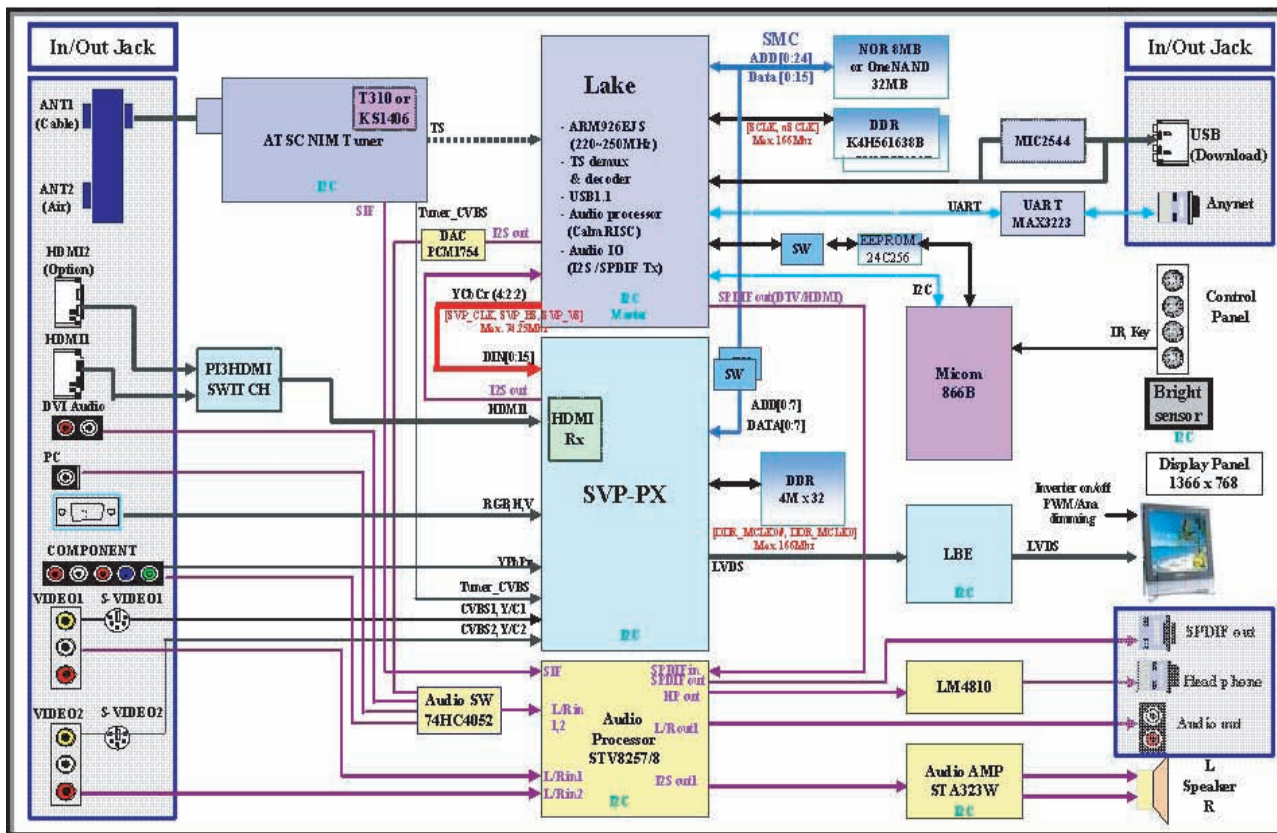

MEMO

8. Wiring Diagram

8-1 Overall Wiring

※ The ASS'Y code can be changed, see "5 Chapter. Electrical Part List."

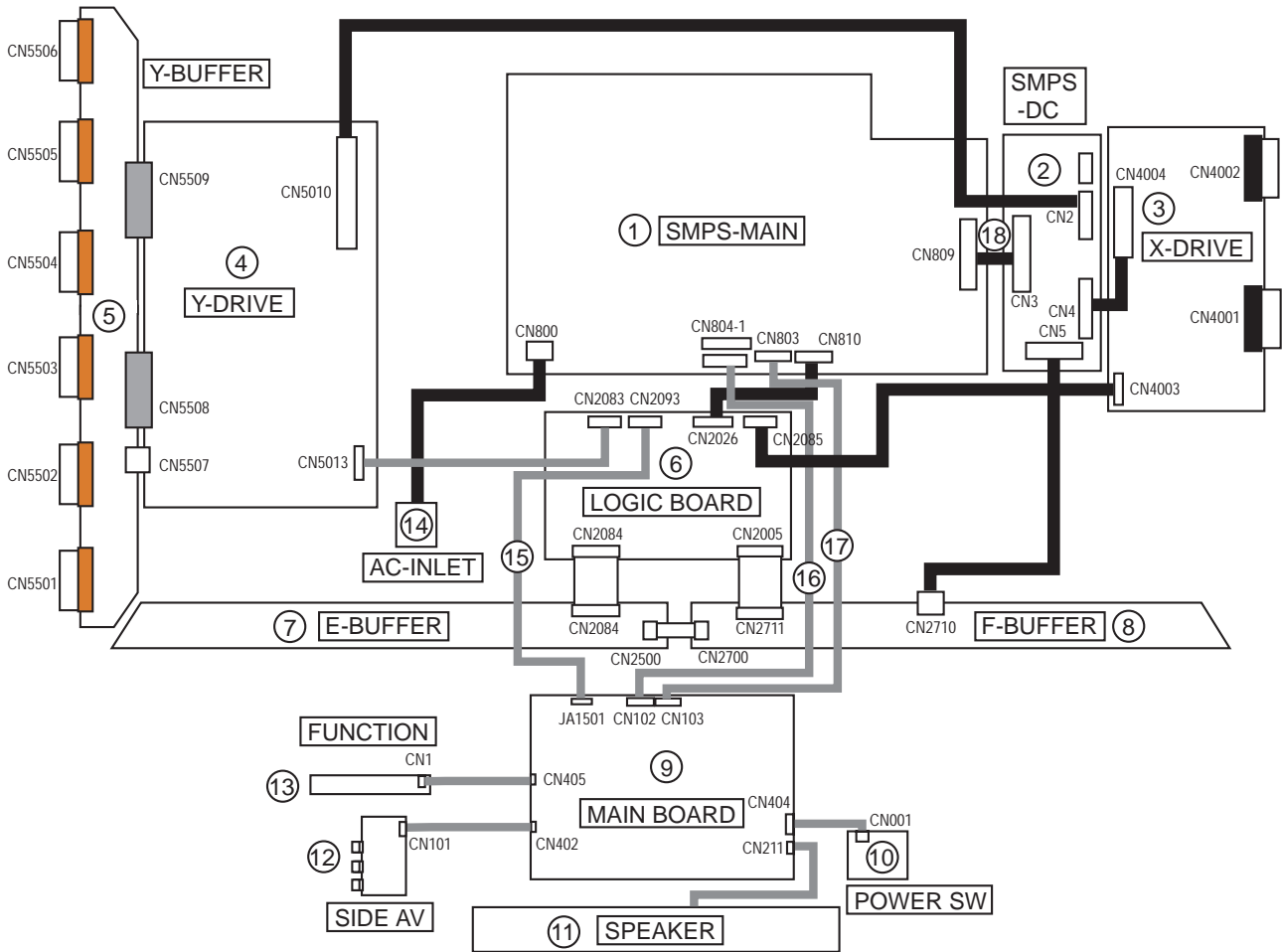

No	Assy	Code No.	Description
-	ASSY PDP MODULE P	BN96-03288A	M1,42HD,V5.1,1024*768,NTSC/PAL,complementary color,with logic
①	ASSY PCB P-SMPS	BN96-03252A	HPS4253,100V-120V,245*370mm
②	ASSY PCB P-SMPS	BN96-01856A	SPD-50P5HD(DC_DC),200Vin(DC_DC)
③	ASSY PDP MODULE P-X MAIN BOARD	BN96-03550A	42HD,PL42AX005A,V5.1,NTSC/PAL,1024*768,LJ92-01345A
④	ASSY PDP MODULE P-Y MAIN BOARD	BN96-03351A	42HD,PL42AX005A,V5.1,NTSC/PAL,1024*768,LJ92-01346A
⑤	ASSY PDP MODULE P-Y MAIN SCAN BUFFER	BN96-03352A	42HD,PL42AX005A,V5.1,NTSC/PAL,1024*768,LJ92-01344A
⑥	ASSY PDP MODULE P-LOGIC MAIN BOARD	BN96-03355A	42HD,PL42AX005A,V5.1,NTSC/PAL,1024*768,sec/sesk
⑦	ASSY PDP P-ADDRESS E BUFFER	BN96-03353A	42HD,PL42AX005A,V5.1,NTSC/PAL,1024*768,LJ92-01343A
⑧	ASSY PDP P-ADDRESS F BUFFER	BN96-03354A	42HD,PL42AX005A,V5.1,NTSC/PAL,1024*768,LJ92-01342A
⑨	ASSY PCB MISC-MAIN	BN94-00859B	HP-S4253,CADILLAC,BN41-00694A
⑩	ASSY BOARD P-POWER&IR	BN96-03320A	CADILLAC,SJ05-01-516,POWER & IR,CORE, 250MM
⑪	ASSY SPEAKER P	BN96-03392A	8ohm,Q7,10W,2Way,2speaker,Bass Reflex
⑫	ASSY BOARD P-SIDE AV	BN96-03075E	CADILLAC,SJ06-01-004E,SIDE-AV,400MM, USA
⑬	ASSY BOARD P-FUNCTION	BN96-02784B	CADILLAC,SJ06-01-006,FUNCTION,600MM, CORE
⑭	FILTER-EMI AC LINE	2901-001378	250V,6A,-,0.15uF/1000pF,50x22.5x37.2mm,BK,-
⑮	LEAD CONNECTOR-LVDS	BN39-00667C	D71C/SPD-42S5HD,UL20276#30,UL/CSA,31P,200mm,
⑯	LEAD CONNECTOR	MD39-00074H	SVP-61L2HD,UL1007#26,UL/CSA,12P,150MM,#26,SMH250-
⑰	LEAD CONNECTOR	BN39-00053D	SCHUBERT,UL1007#26,10P,150MM,#26,SMH250-10,SMH250-
⑱	LEAD CONNECTOR	BN39-00632B	PS-42E7HX/XEC,UL1617#22,UL/CSA,12PIN,150MM,#22,35156-

8-2 Partial Wiring



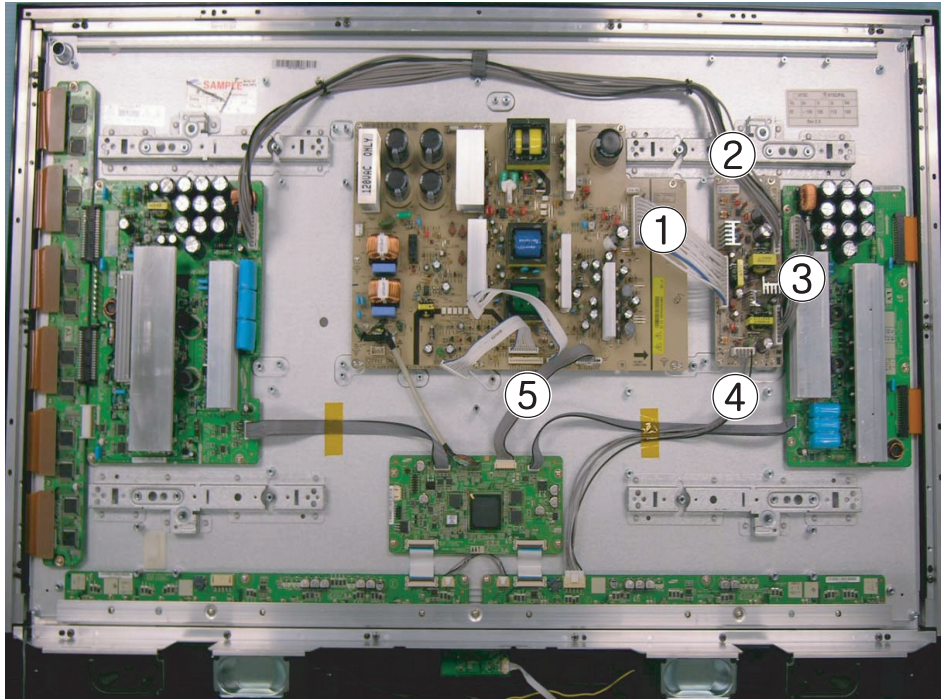

8-2-1 PDP Module ↔ SMPS Wiring

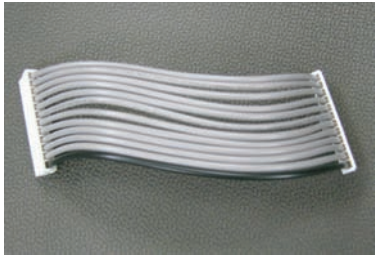

① CN809(Main SMPS) ↔ CN3(DC-DC SMPS)		② CN2(DC-DC SMPS) ↔ CN5010(Y B'D)		③ CN4(DC-DC SMPS) ↔ CN4004(X B'D)		④ CN5(DC-DC SMPS) ↔ CN2710(F-Buffer)		⑤ CN809(Main SMPS) ↔ CN2085(Main B'D)	
Pin No.	Signal	Pin No.	Signal	Pin No.	Signal	Pin No.	Signal	Pin No.	Signal
1	D5.3V	1	D5.3V	1	D5.3V	1	RTN	1	STD 5V
2	Vg	2	Vg	2	Vg	2	N.C	2	Vs-ON
3	RTN	3	RTN	3	RTN	3	D5.3V	3	N.C
4	RTN	4	Vscan	4	RTN	4	N.C	4	PS-ON
5	RTN	5	RTN	5	Ve	5	Va	5	RTN
6	RTN	6	Vset	6	RTN			6	D5.3V
7	RTN	7	RTN	7	RTN			7	RTN
8	Va	8	RTN	8	Vs			8	RTN
9	Va	9	Vs	9	Vs			9	D5.3V
10	N.C	10	Vs					10	D5.3V
11	Vs								
12	Vs								

8-2-2 Connect Cables

※ The code number of cable(Lead-connector) can be changed, see "5 Chapter. Electrical Part List."

Use	SMPS 12P	LVDS 31P	POWER 10P
Code	BN39-00632B	BN39-00667C	BN39-00053D
Photo			
Use	POWER 12P		
Code	MD39-00074H		
Photo			

9. PCB Diagram

9-1 Main Board

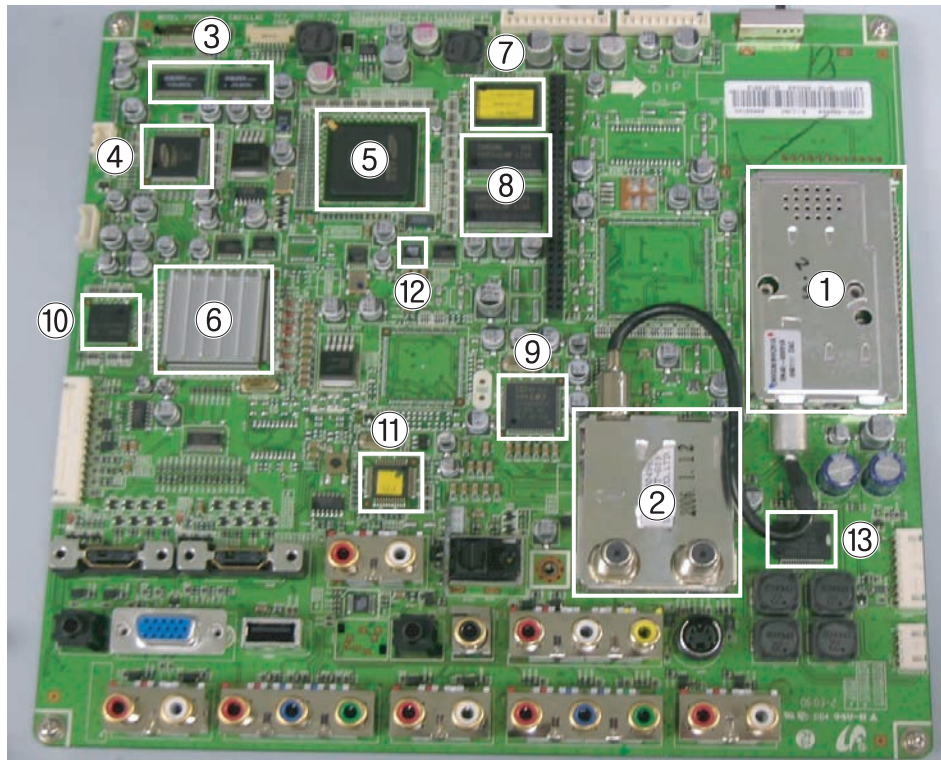

No	Loc. No.	Description
①	TU301 (DNVS303HH261A)	TUNER
②	X301 (UMX-NT-059)	MODULE-SPLITTER
③	IC1502, IC1504 (DTC34LM85A)	IC-TRANSMITTER (LVDS TRANSMITTER)
④	IC1503 (S4LD158X01)	IC VIDEO PROCESSOR (DNIE-LBE)
⑤	IC2001 (S5H2111)	IC-DECODER
⑥	IC1001 (SVP-PX56)	IC VIDEO PROCESSOR
⑦	IC2032 (28F640)	IC-FLASH MEMORY
⑧	IC2201, IC2202 (K4D551638F)	IC-DRAM
⑨	IC202 (STV8258DSX)	IC-AUDIO PROCESSOR
⑩	IC1003 (K4D263238)	IC-VIDEO RAM
⑪	IC111 (S3F866B)	IC-MICROCONTROLLER
⑫	IC505 (PCM1754)	IC-D/A CONVERTER
⑬	IC211 (STA323W)	IC-AUDIO AMP

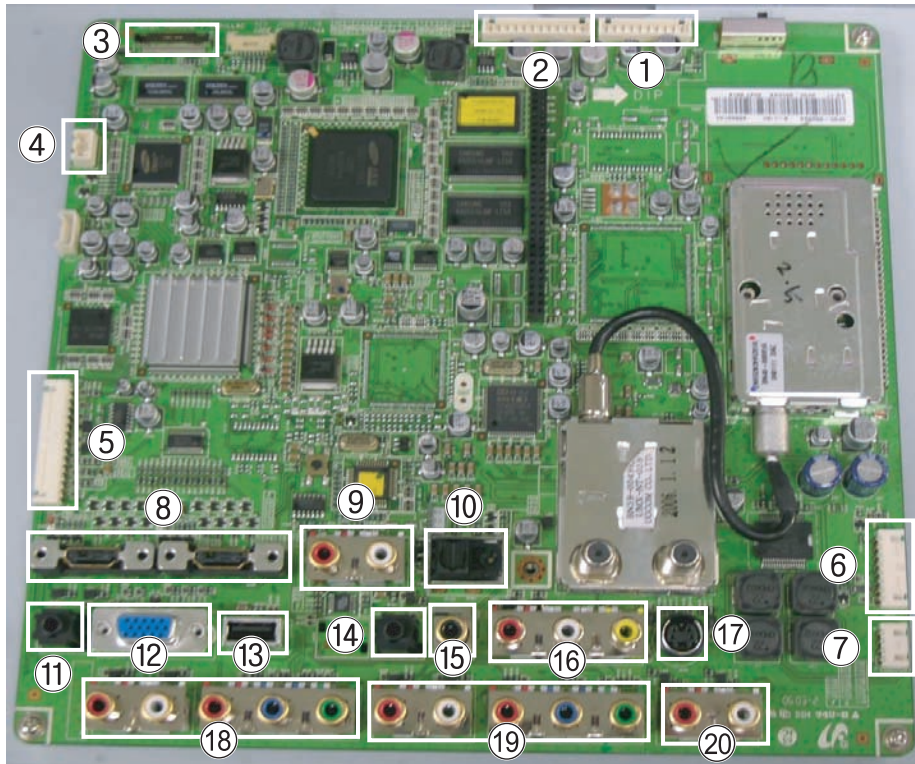

No	Loc. No.	Description
①	CN101	Analog Power
②	CN102	Digital Power
③	JA1501	LVDS out
④	CN405	Function Connector
⑤	CN402	Side-AV Connector
⑥	CN404	Power&IR Connector
⑦	CN211	Speaker out
⑧	JA502, JA503	HDMI
⑨	JA505	DVI L/R
⑩	OP401	Digital Out (Optical)
⑪	JA503	Audio IN (PC)
⑫	CN501	PC
⑬	CN2001	Service1
⑭	JA409	Service2
⑮	CN401	Digital Out (Optical)
⑯	JA401	AV IN
⑰	JA407	S-Video
⑱	JA406, JA405	Component 2
⑲	JA403, JA402	Component 1
⑳	JA404	Audio Out (L/R)

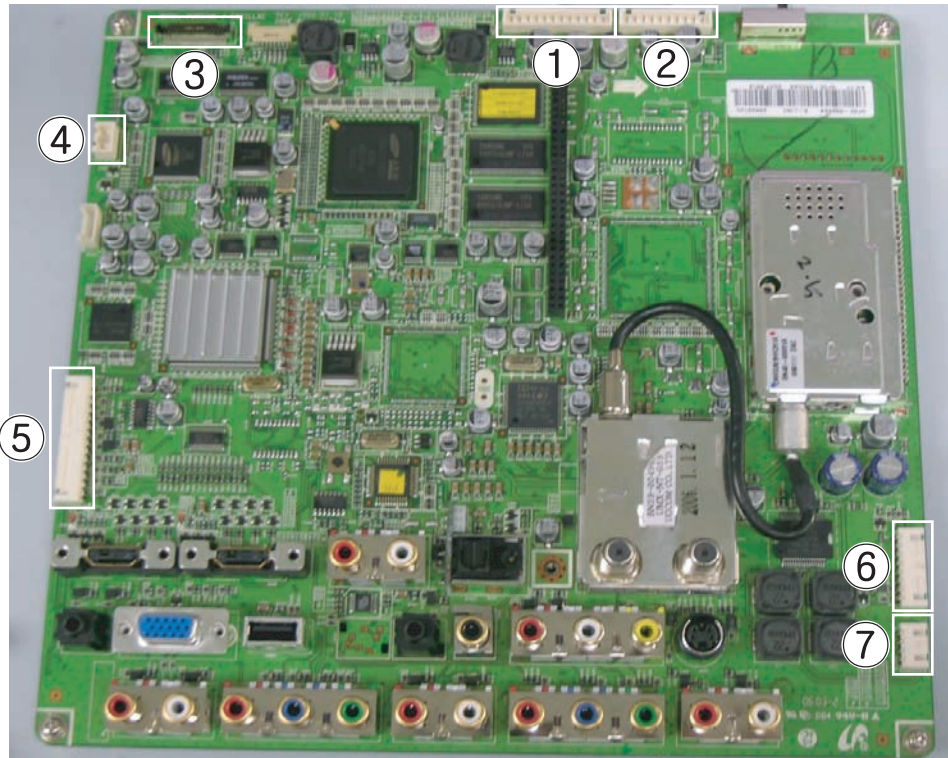

① CN1002(Main B'D) ↔ CN804-1(Main SMPS)		② CN101(Main B'D) ↔ CN803(Main SMPS)	
Pin No.	Signal	Pin No.	Signal
1	NC	1	GND
2	NC	2	B33V
3	A5V	3	GND
4	GND	4	GND
5	SW_POWER	5	+18_A
6	B12V	6	+18_A
7	GND	7	GND
8	GND	8	GND
9	NC	9	GND
10	NC	10	A6V
11	GND		
12	D6V		

③ JA1501(Main B'D) ↔ CN2093(Logic B'D)					
Pin No.	Signal	Pin No.	Signal	Pin No.	Signal
1	GND	12	12BIT_Tx_2+	23	12BIT_Tx_0b-
2	GND	13	TXOUT3B-	24	12BIT_Tx_0b+
3	12BIT_Tx_0-	14	TXOUT3B+	25	LOGIC_DPMS
4	12BIT_Tx_0+	15	12BIT_Tx_CLK-	26	GND
5	GND	16	12BIT_Tx_CLK-	27	SCL4_TV_3.3V
6	GND	17	12BIT_Tx_CLKb-	28	GND
7	12BIT_Tx_1-	18	12BIT_Tx_CLKb+	29	SDA4_TV_3.3V
8	12BIT_Tx_1+	19	12BIT_Tx_3-	30	GND
9	12BIT_Tx_1b-	20	12BIT_Tx_3+	31	
10	12BIT_Tx_1b+	21	GND	32	
11	12BIT_Tx_2-	22	I2C_READY	33	

④ CN405(Main B'D) ↔ FUNCTION	
Pin No.	Signal
1	KEY1
2	KEY2
3	GND

⑤ CN402(Main B'D) ↔ SIDE AV	
Pin No.	Signal
1	VIDEO2_CVBS
2	GND
3	VIDEO2_IDENT
4	SVHS IDENT
5	VIDEO2_SL_IN
6	HP_OUT_L
7	VIDEO2_SR_IN
8	HP_OUT_R
9	SVHS2_Y
10	GND
11	SVHS2_C
12	GND
13	HP_IDENT
14	GND

⑥ CN404(Main B'D) ↔ POWER&IR	
Pin No.	Signal
1	GND
2	LED_ON_OFF
3	A5V
4	GND
5	KEY2
6	SDA5_TV_5V
7	SCL_TV_5V
8	IR

⑦ CN211(Main B'D) ↔ SPEAKER	
Pin No.	Signal
1	R+_OUT
2	R-_OUT
3	L+_OUT
4	L-_OUT

9-2 Power & IR Board

No	Loc. No.	Description
①	RM1	Remote Control Sensor
②	SW1	Power Button
③	OP1	The Illumination sensor that senses the quantity of light. It senses the illumination and automatically adjusts the screen brightness according to the surrounding brightness when the Power Saving Mode of the User menu is set to Auto.

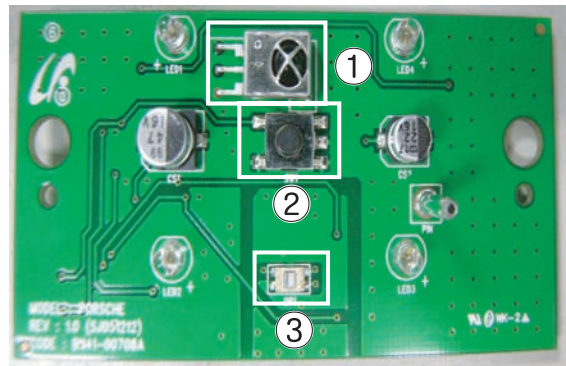

9-3 Function Board

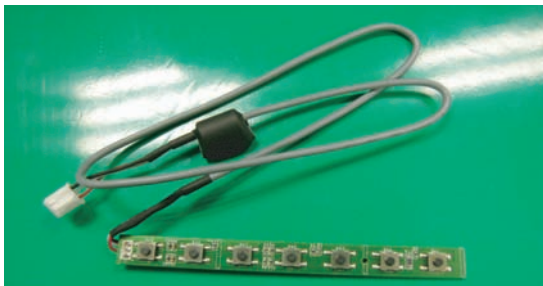

Function Key. Located on the side of the unit.

9-4 Side AV Board

No	Loc. No.	Description
①	CN102	S-VIDEO2 Input Jack
②	CN103	AV2 Input Jack
③	CN104	Earphone Jack
④	CN105	Side AV Connector

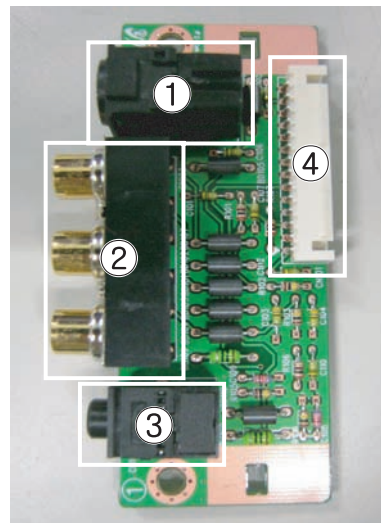

9-5 Main SMPS Board

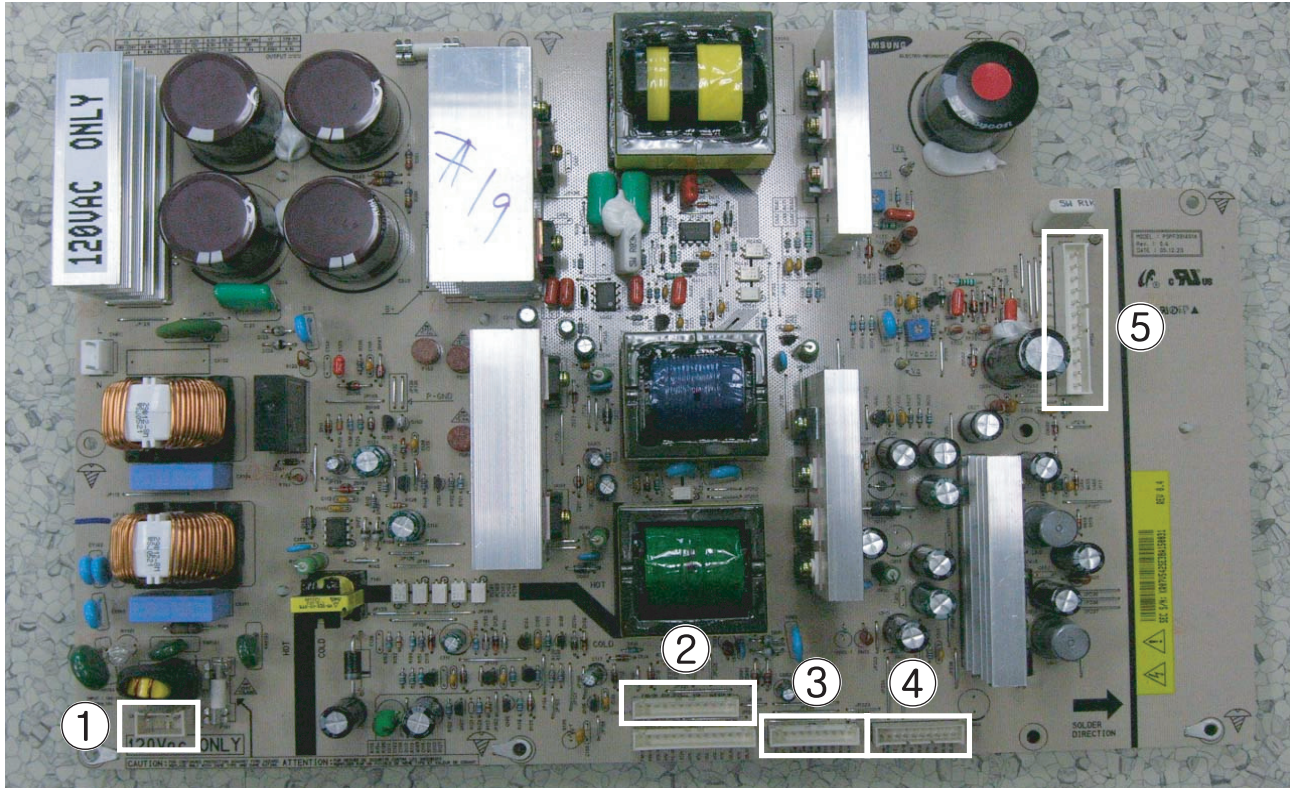

① CN800 : AC IN (110V)

② CN804-1(Main SMPS) ↔ CN102(Main B'D)		③ CN803(Main SMPS) ↔ CN101(Main B'D)		④ CN810(Main SMPS) ↔ CN2085(Logic B'D)		⑤ CN809(Main SMPS) ↔ CN3(DC-DC SMPS)	
Pin No.	Signal	Pin No.	Signal	Pin No.	Signal	Pin No.	Signal
1	D5.3V	1	6.5V	1	D5.3V	1	D5.3V
2	RTN	2	RTN	2	D5.3V	2	Vg
3	VCS	3	A12V	3	RTN	3	RTN
4	VCA	4	RTN	4	RTN	4	RTN
5	RTN	5	18V-AMP	5	D5.3V	5	RTN
6	RTN	6	18V-AMP	6	RTN	6	RTN
7	D12V	7	RTN-AMP	7	PS_ON	7	RTN
8	PS_ON	8	RTN-AMP	8	N.C	8	Va
9	RTN	9	VT	9	VS_ON	9	Va
10	STB-5V	10	RTN	10	STB-5V	10	N.C
11	FAN_ON					11	Vs
12	FAN_D					12	Vs

9-6 DC-DC SMPS Board

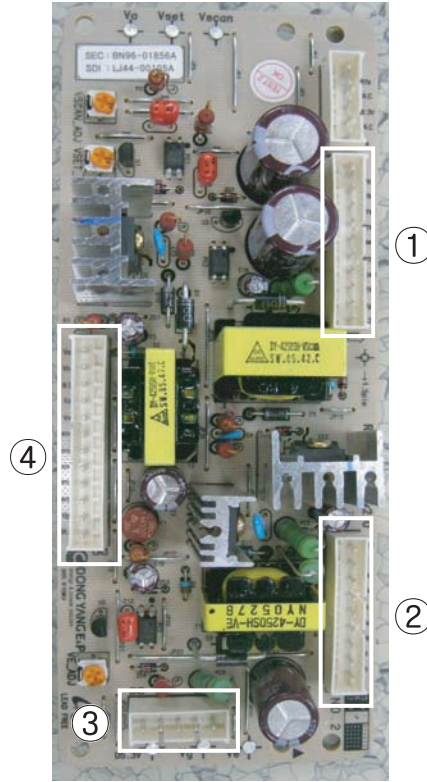

① CN2(DC-DC SMPS) ↔ CN5010(Y B'D)		② CN4(DC-DC SMPS) ↔ CN4004(X B'D)		③ CN5(DC-DC SMPS) ↔ CN2710(F-Buffer)		④ CN3(DC-DC SMPS) ↔ CN809(Main SMPS)	
Pin No.	Signal	Pin No.	Signal	Pin No.	Signal	Pin No.	Signal
1	Vs	1	Vs	1	RTN	1	D5.3V
2	Vs	2	Vs	2	N.C	2	Vg
3	RTN	3	RTN	3	D5.3V	3	RTN
4	RTN	4	RTN	4	N.C	4	RTN
5	Vset	5	Ve	5	Va	5	RTN
6	RTN	6	RTN			6	RTN
7	Vscan	7	RTN			7	RTN
8	RTN	8	Vg			8	Va
9	Vg	9	D5.3V			9	Va
10	D5.3V					10	N.C
						11	Vs
						12	Vs

9-7 PDP Module

※ The ASS'Y code can be changed, see "5 Chapter. Electrical Part List."

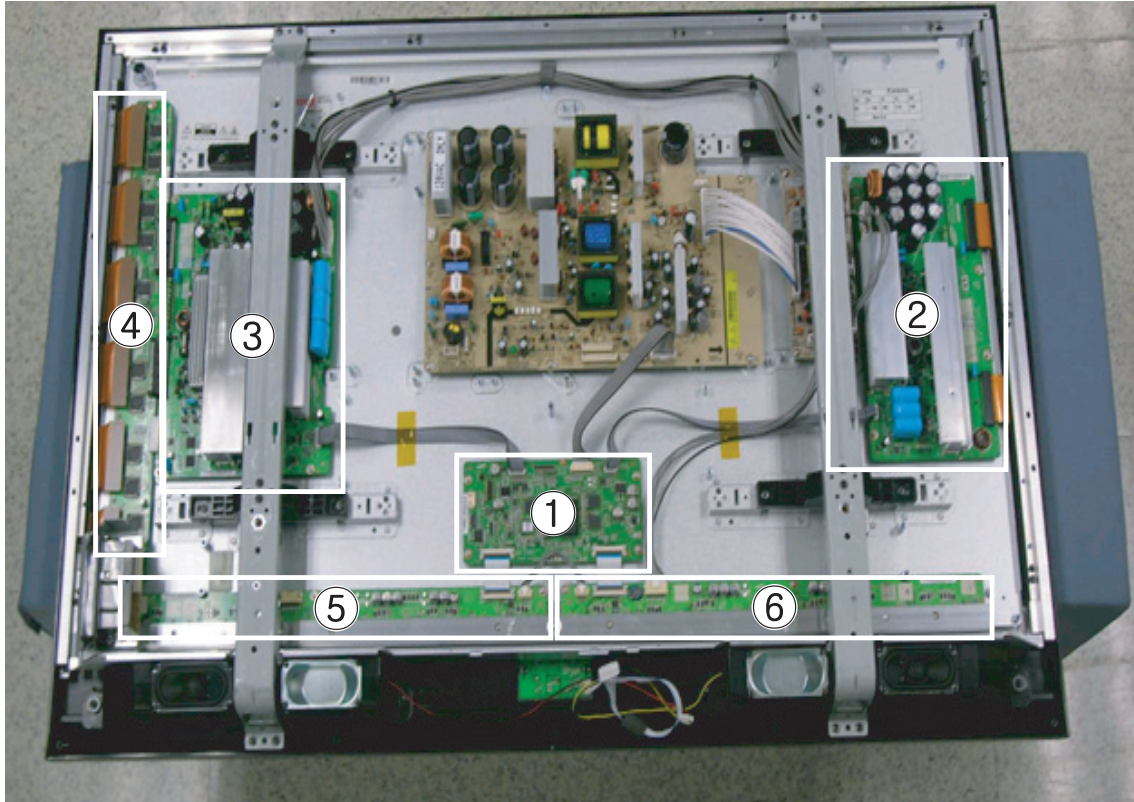

No	Assy	Code No.	Description
①	ASSY PDP MODULE P-LOGIC MAIN BOARD	BN96-03355A	Logic Main Board
②	ASSY PDP MODULE P-X MAIN BOARD	BN96-03350A	X Drive Board
③	ASSY PDP MODULE P-Y MAIN BOARD	BN96-03351A	Y Drive Board
④	ASSY PDP MODULE P-Y MAIN SCAN BUFFER	BN96-03352A	Y Buffer Board
⑤	ASSY PDP MODULE P-ADDRESS E BUFFER	BN96-03353A	Address Buffer Board
⑥	ASSY PDP MODULE P-ADDRESS F BUFFER	BN96-03354A	Address Buffer Board

10. Schematic Diagram

10-1 MAIN POWER BLOCK

This Document can not be used without Samsung's authorization.

	Power
	Signal

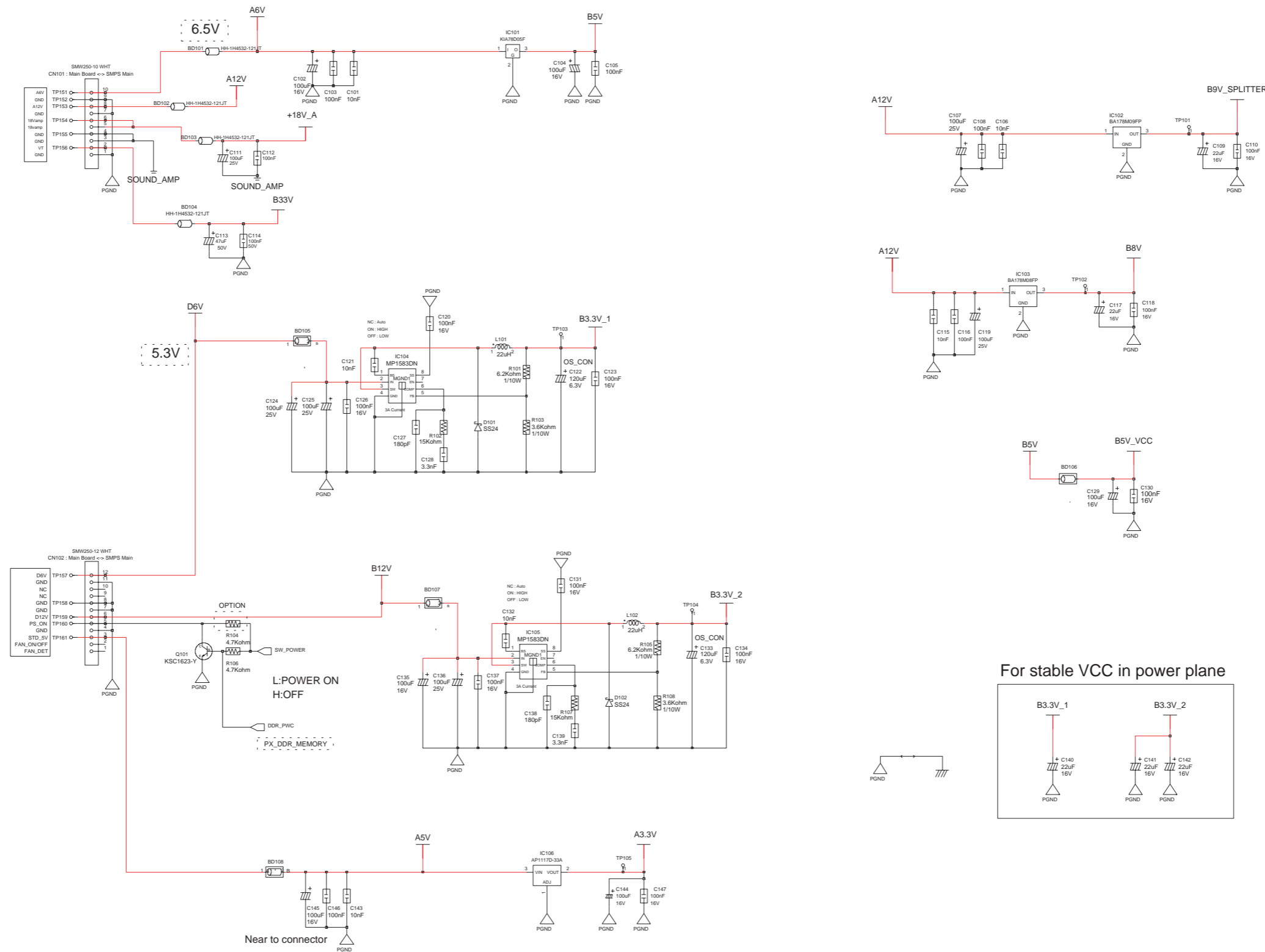

For stable VCC in power plane

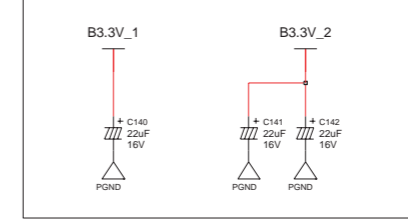

STANDBY POWER

10-2 STANDBY MICOM (S3F866B)

This Document can not be used without Samsung's authorization.

—	Power
—	Signal

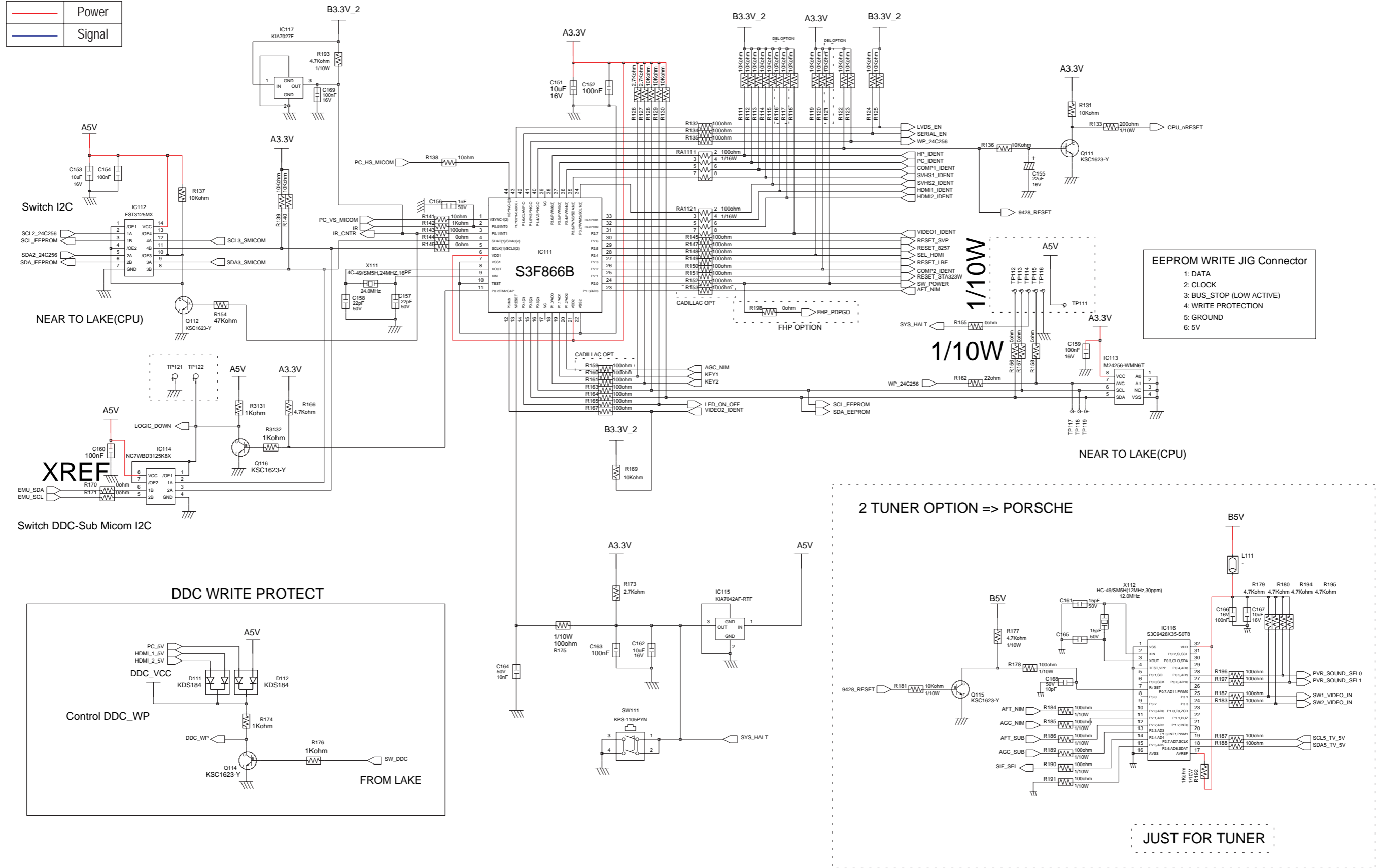

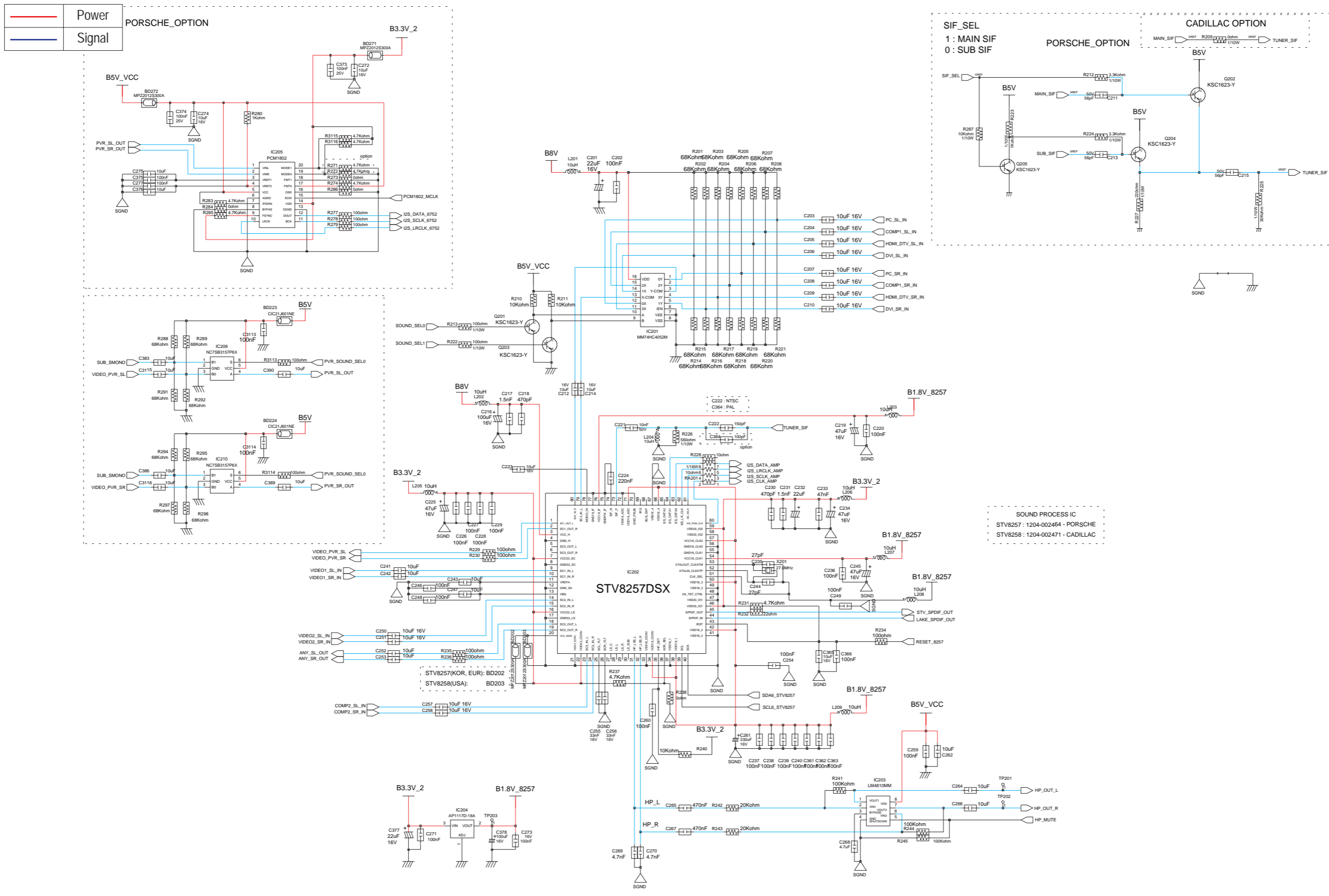

10-3 SOUND PROCESSOR (STV8257)

This Document can not be used without Samsung's authorization.



10-4 SOUND AMP (STA323W) & POP SOLUTION

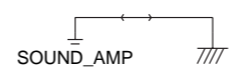
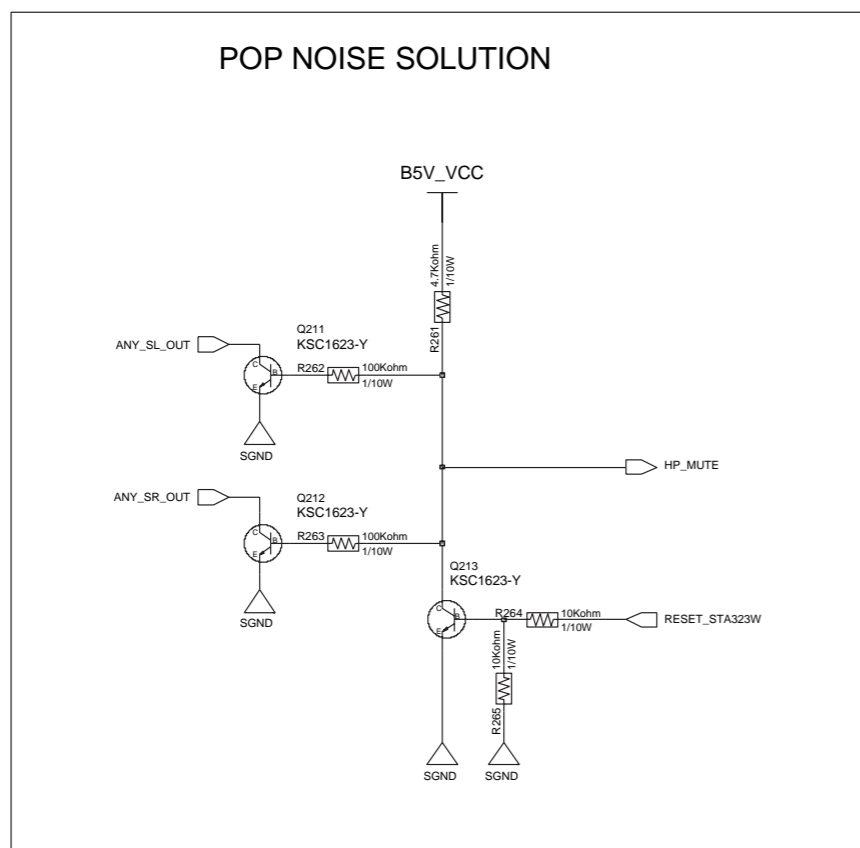
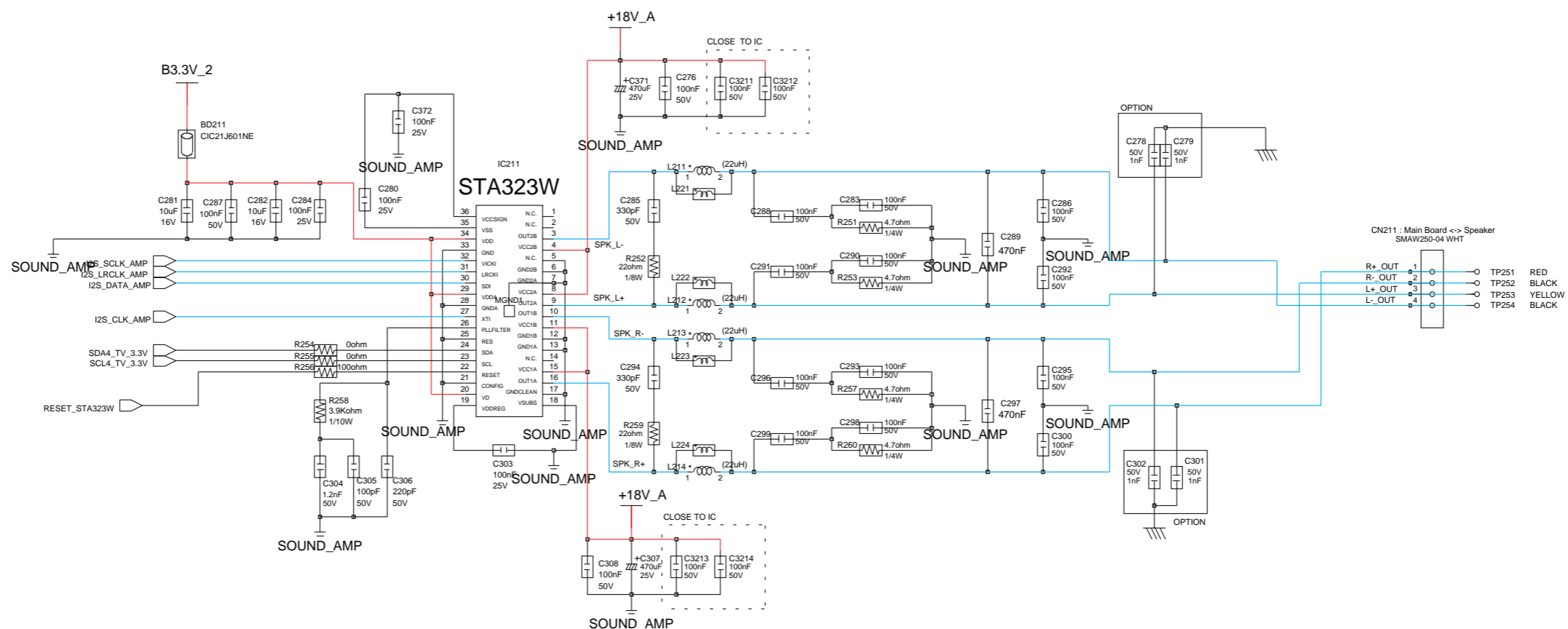

This Document can not be used without Samsung's authorization.

	Power
	Signal



10-5 TUNER & SPLITTER

This Document can not be used without Samsung's authorization.

	Power
	Signal

ATSC NIM TUNER

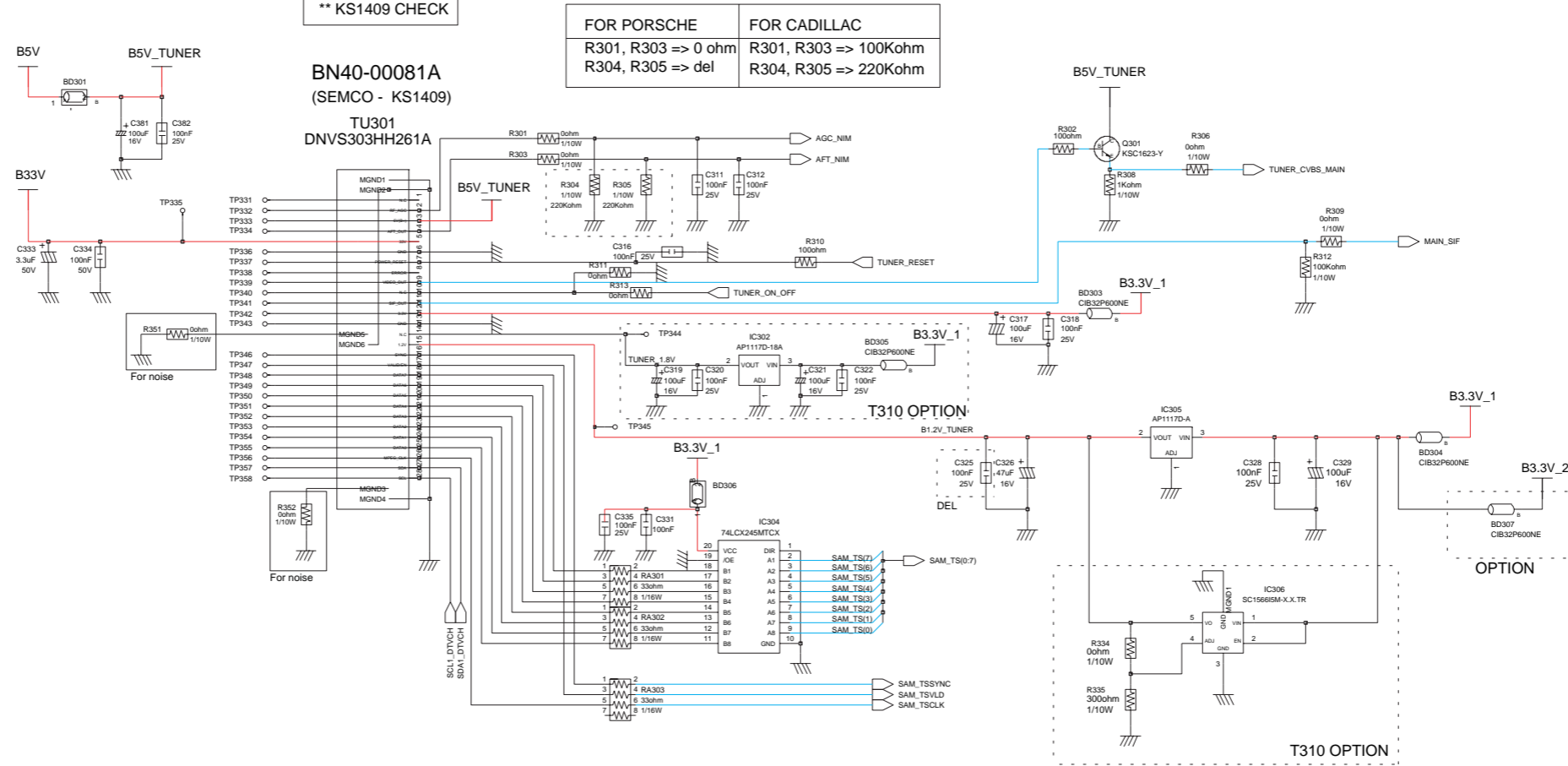

RF-SPLITTER

BN59-00498A (UMX-NT-059) => CADILLAC
 BN59-00505A (UMX-NT-063) => PORSCHE

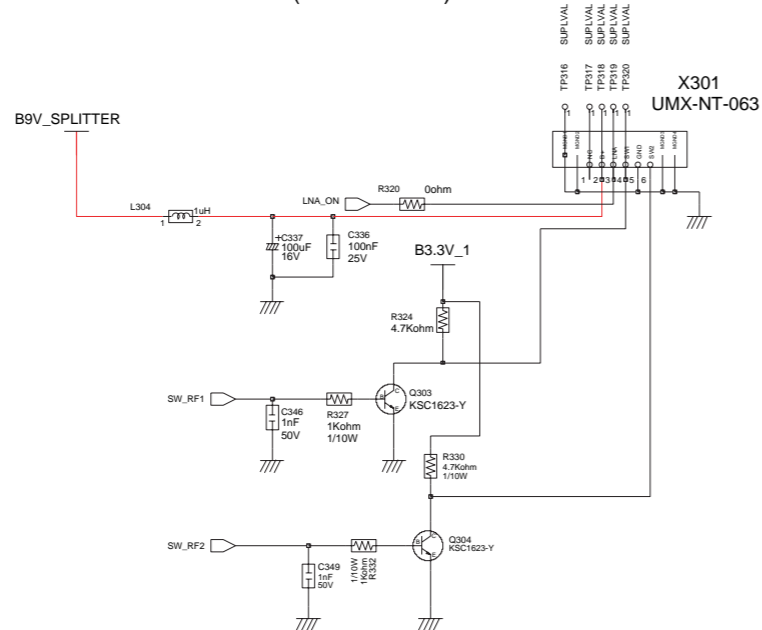

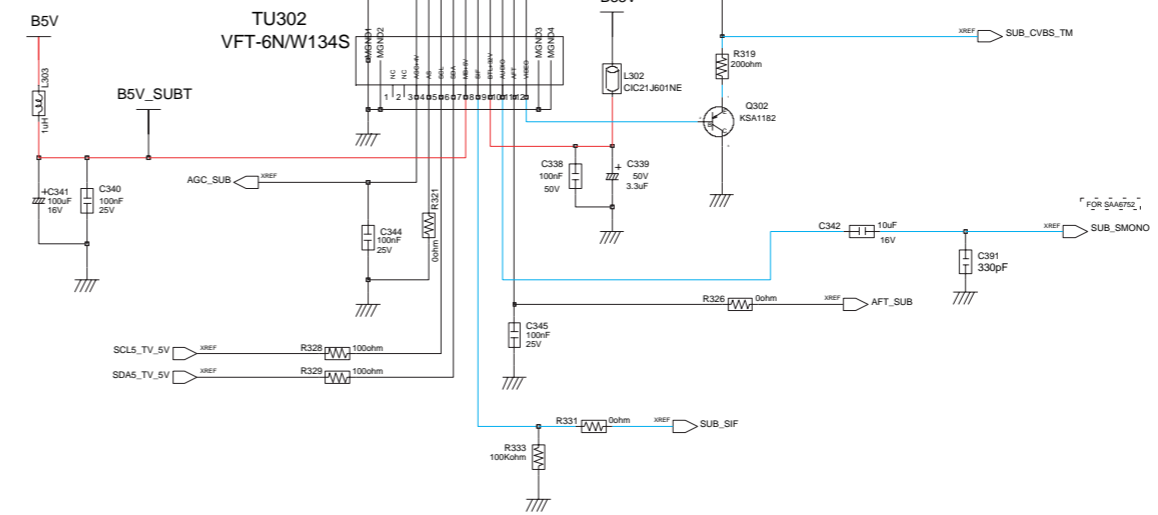

SUB TUNER

FOR PORSCHE
 XuGuang => BN40-00073A



10-6 AV INPUT / OUTPUT

This Document can not be used without Samsung's authorization.

	Power
	Signal

AV INPUT 1

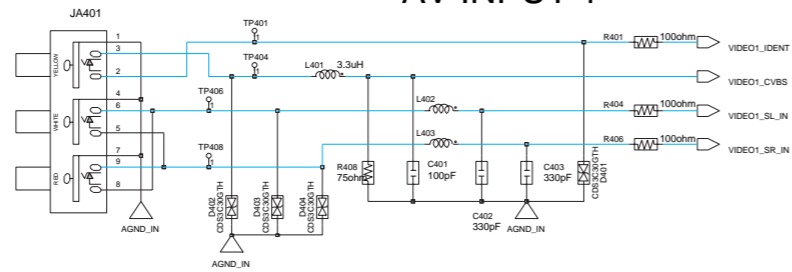

SOUND OUTPUT

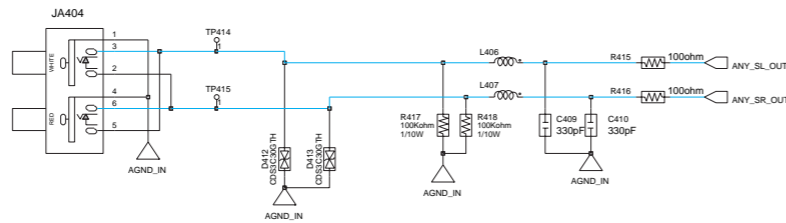

SVHS INPUT 1

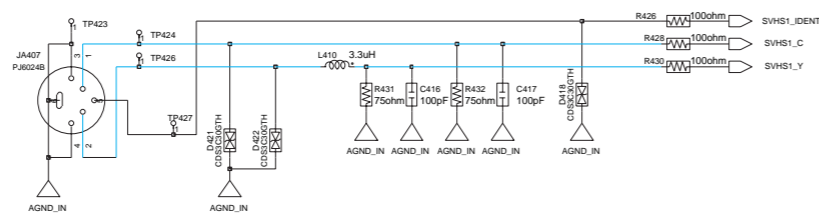

COMPONENT 1

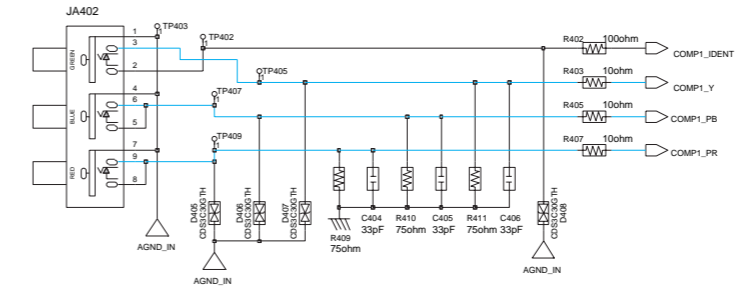

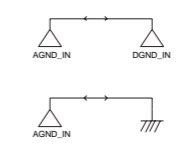
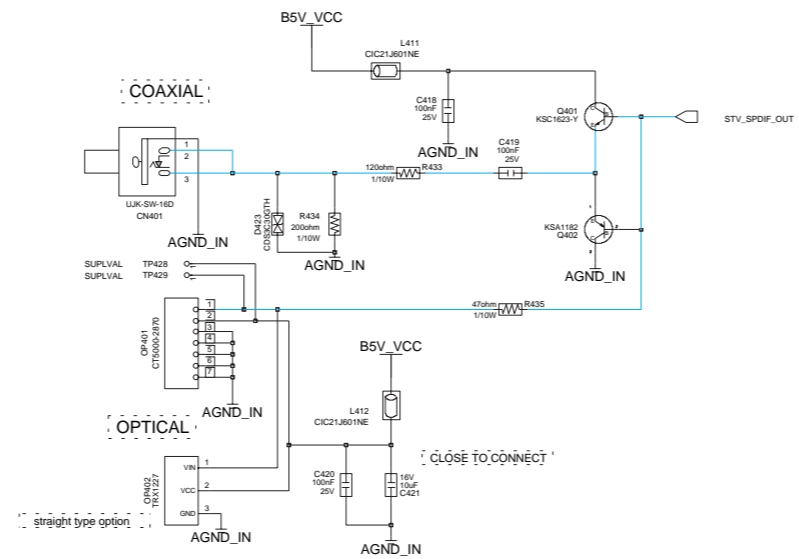
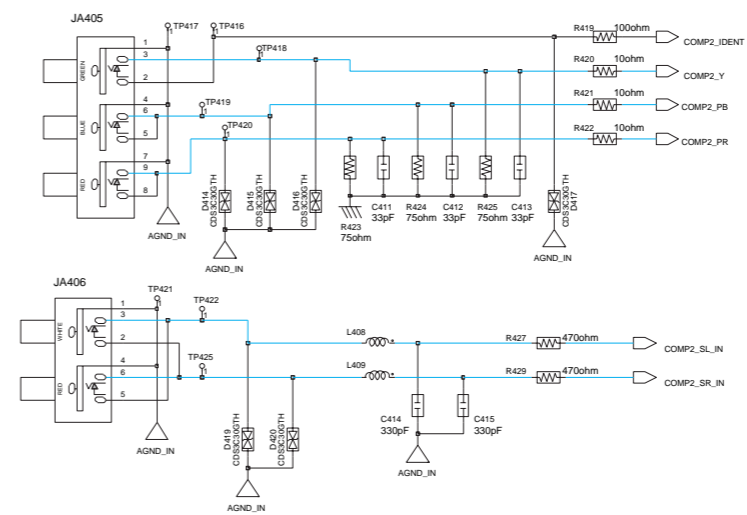

COMPONENT 2



10-7 SIDE-AV & ANYNET & SUB FUNCTION I/F

This Document can not be used without Samsung's authorization.

	Power
	Signal

SIDE_AV

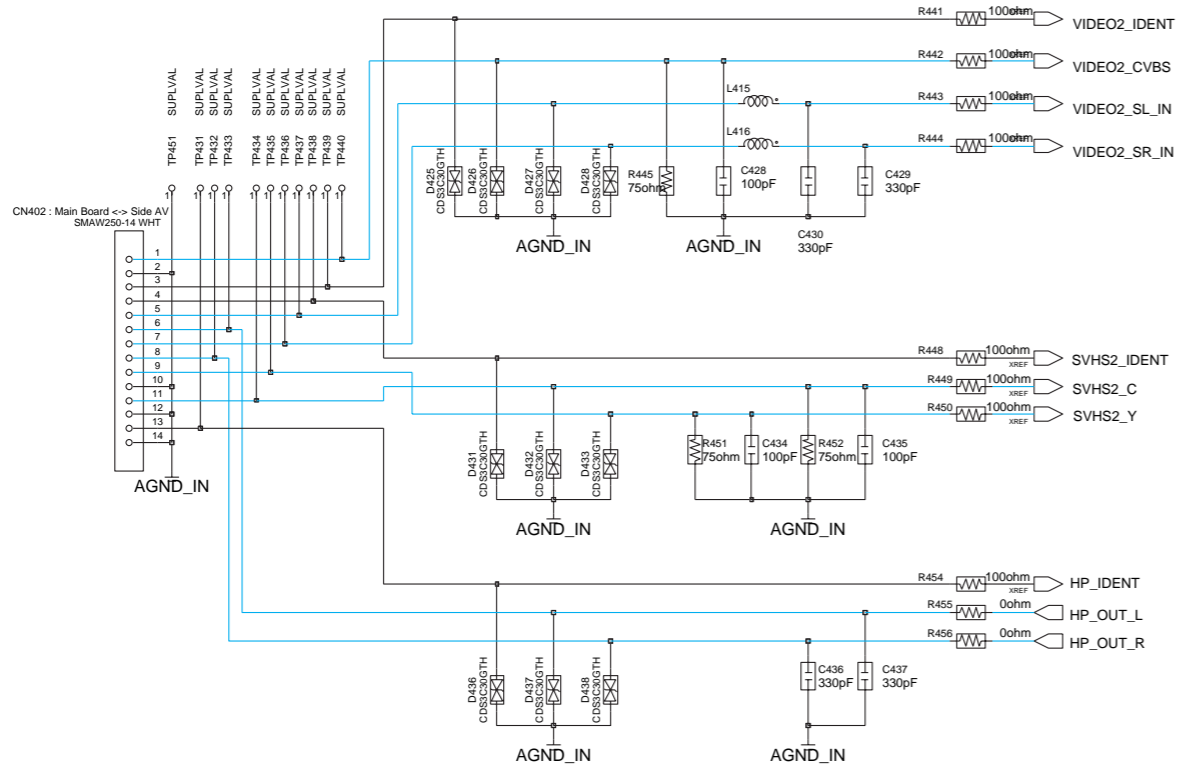

- ANYNET
- Debugger
- Logic Download

ANYNET & SERVICE I/F

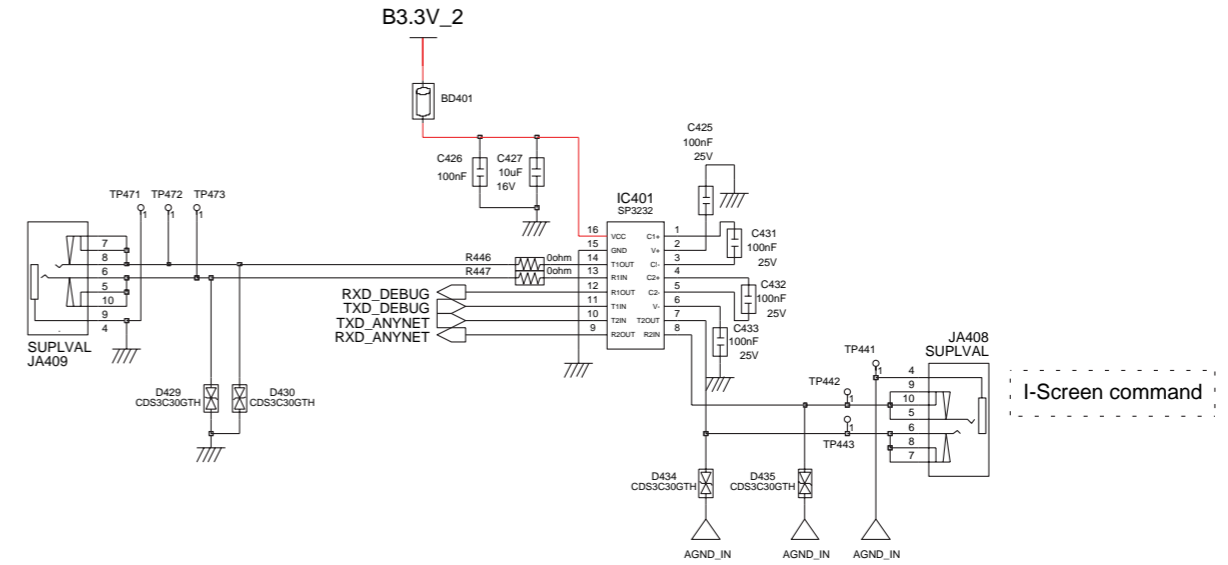

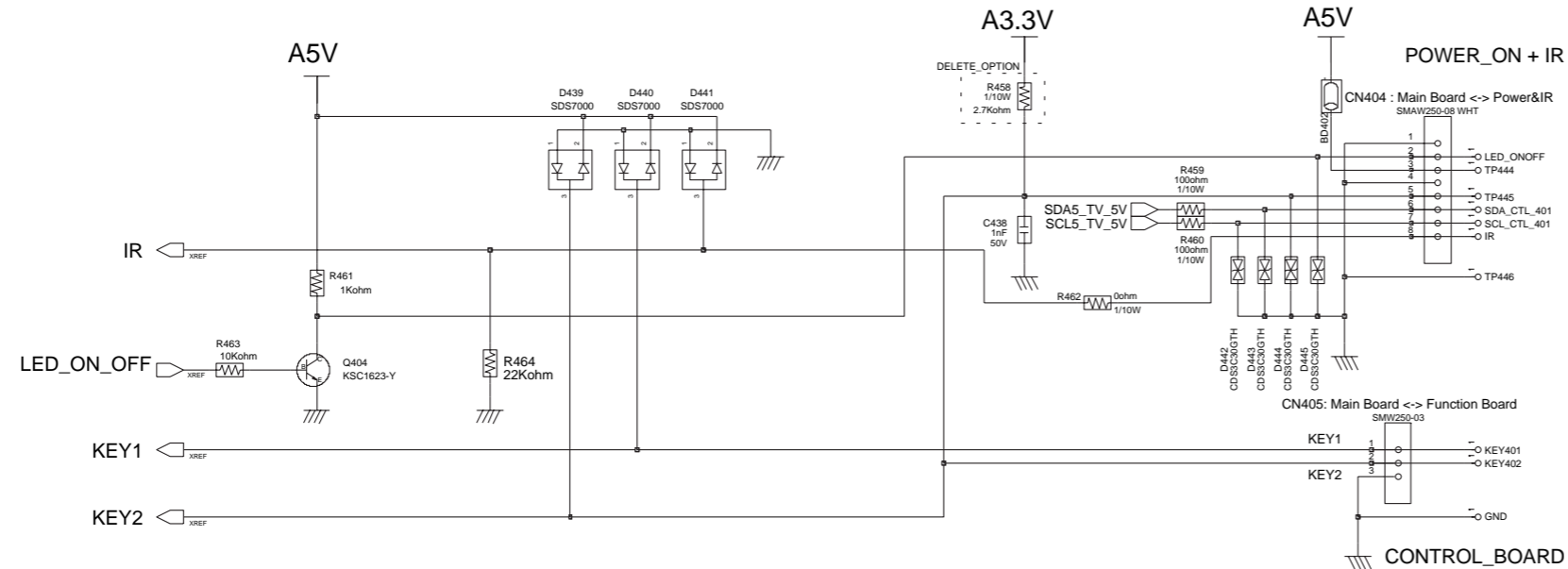

I-Screen command

FUNCTION ASSY



10-8 PC & HDMI INPUT

This Document can not be used without Samsung's authorization.

	Power
	Signal

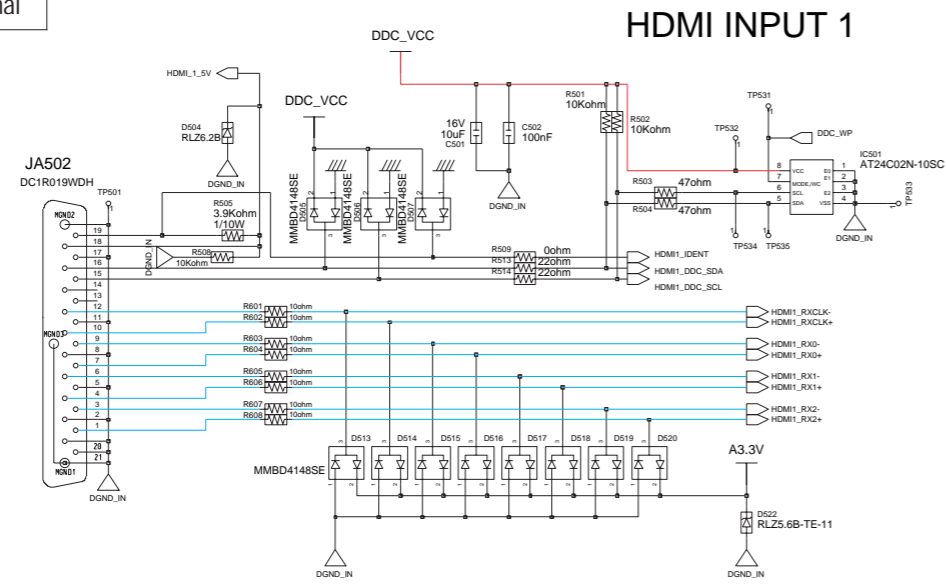

SMT TYPE

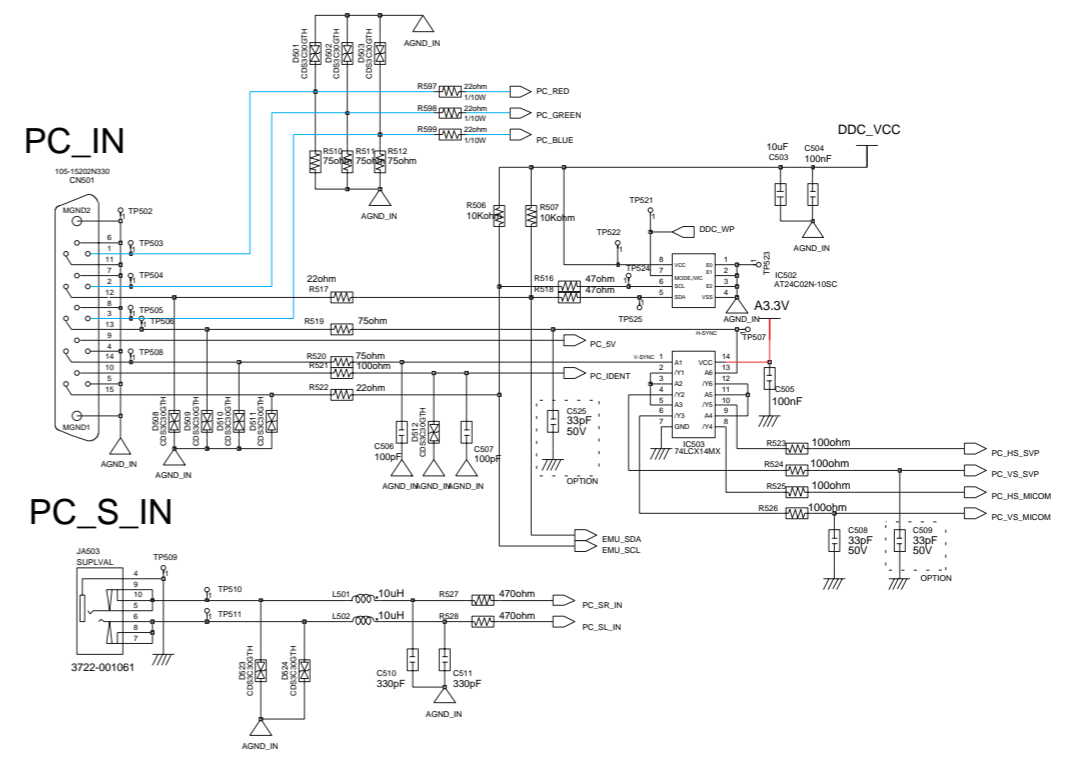
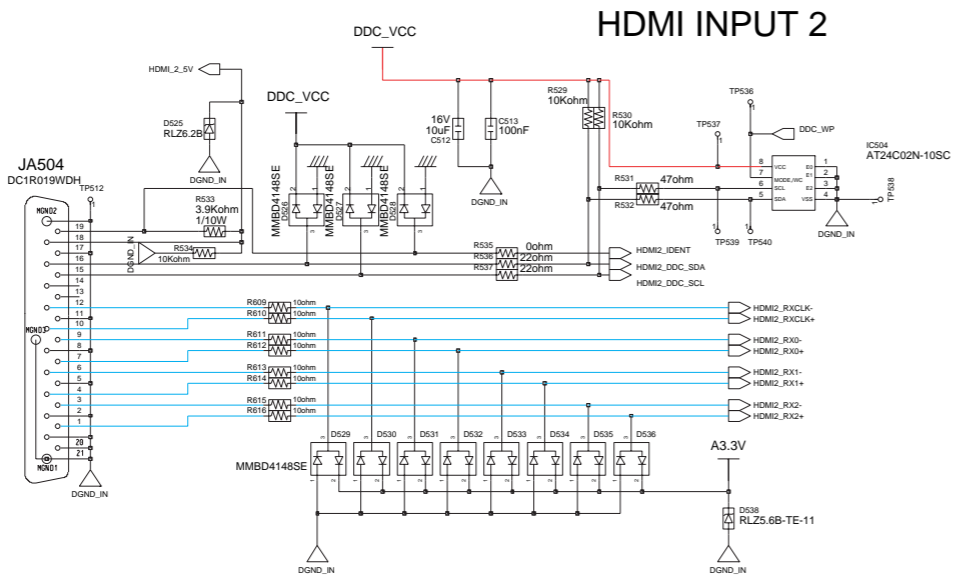

HDMI SWITCH

SEL_HDMI	HIGH	LOW
OUTPUT	HDMI2	HDMI1

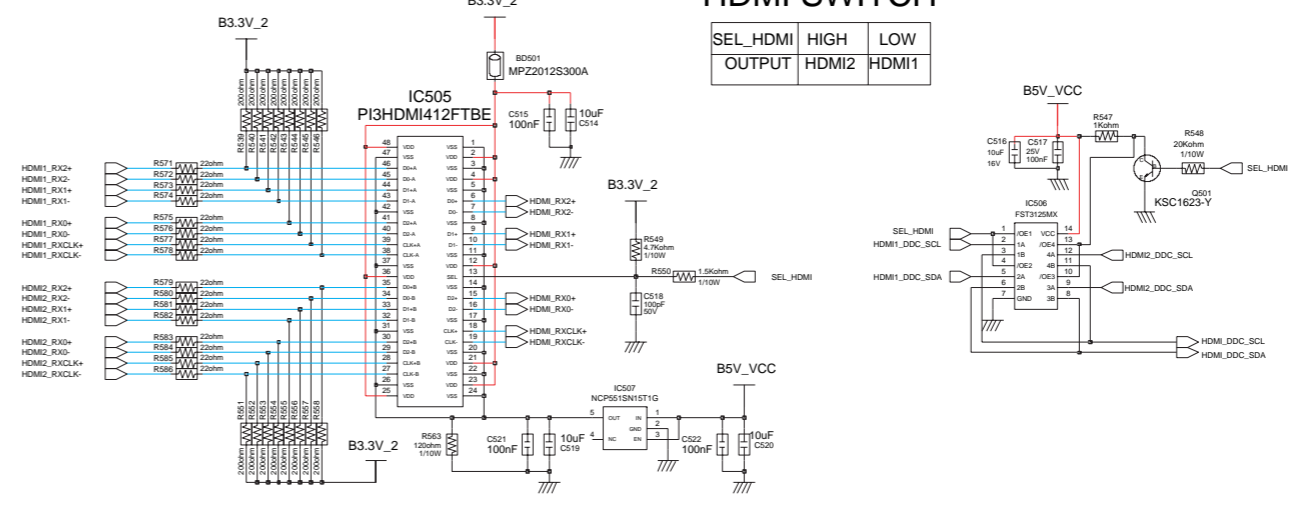

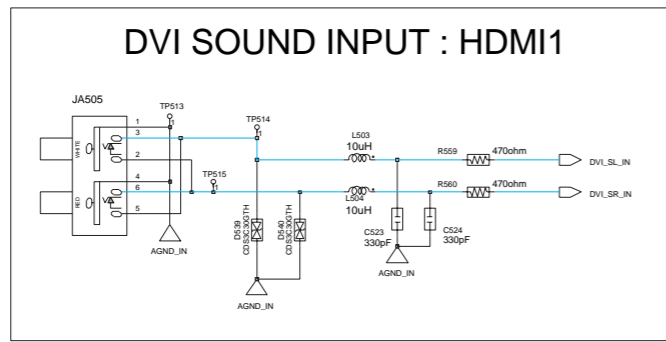

DVI SOUND INPUT : HDMI1



10-9 VIDEO DECODER & SCALER (SVP-PX)

This Document can not be used without Samsung's authorization.

	Power
	Signal

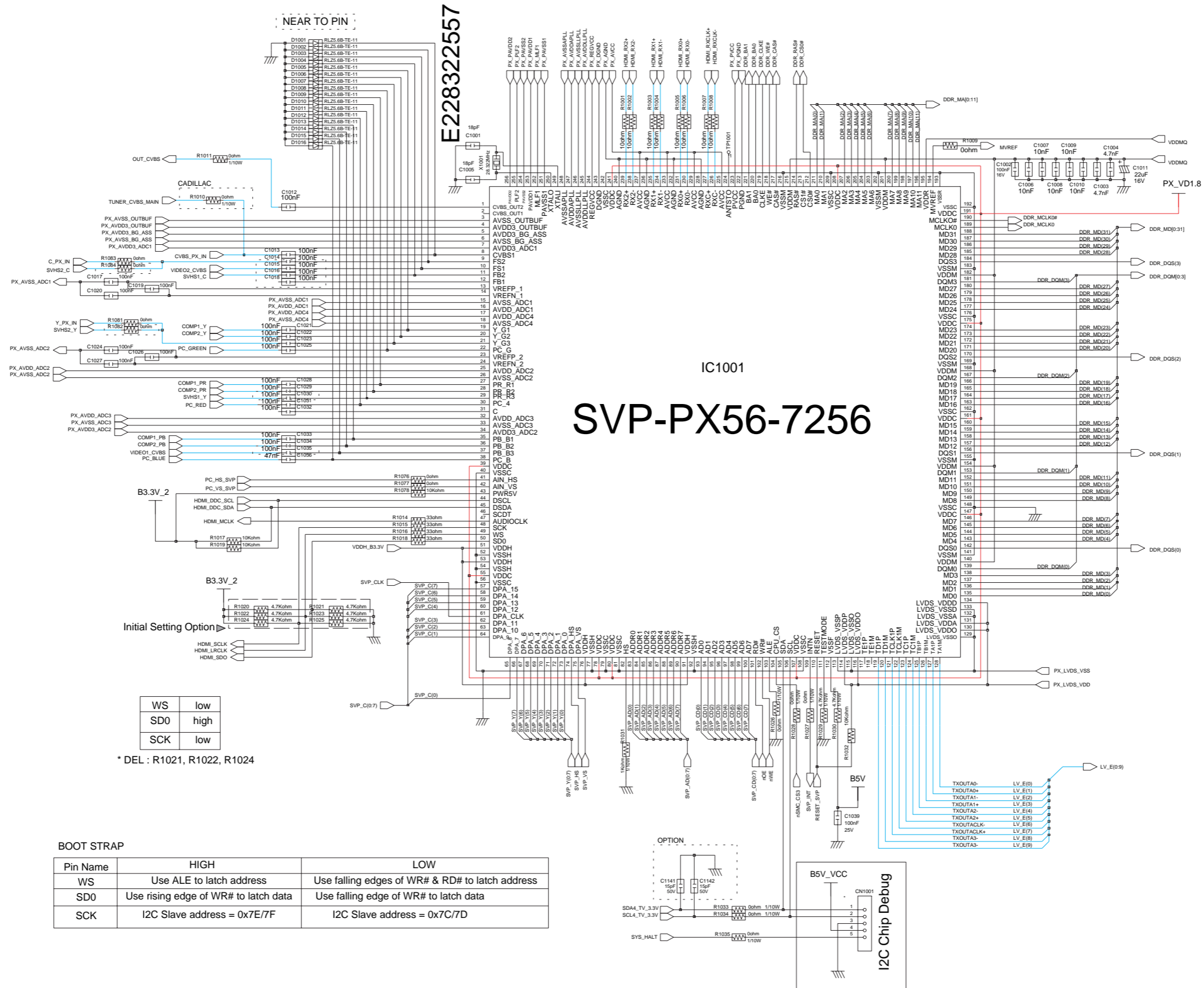

10-10 SVP-PX DDR MEMORY

This Document can not be used without Samsung's authorization.

	Power
	Signal

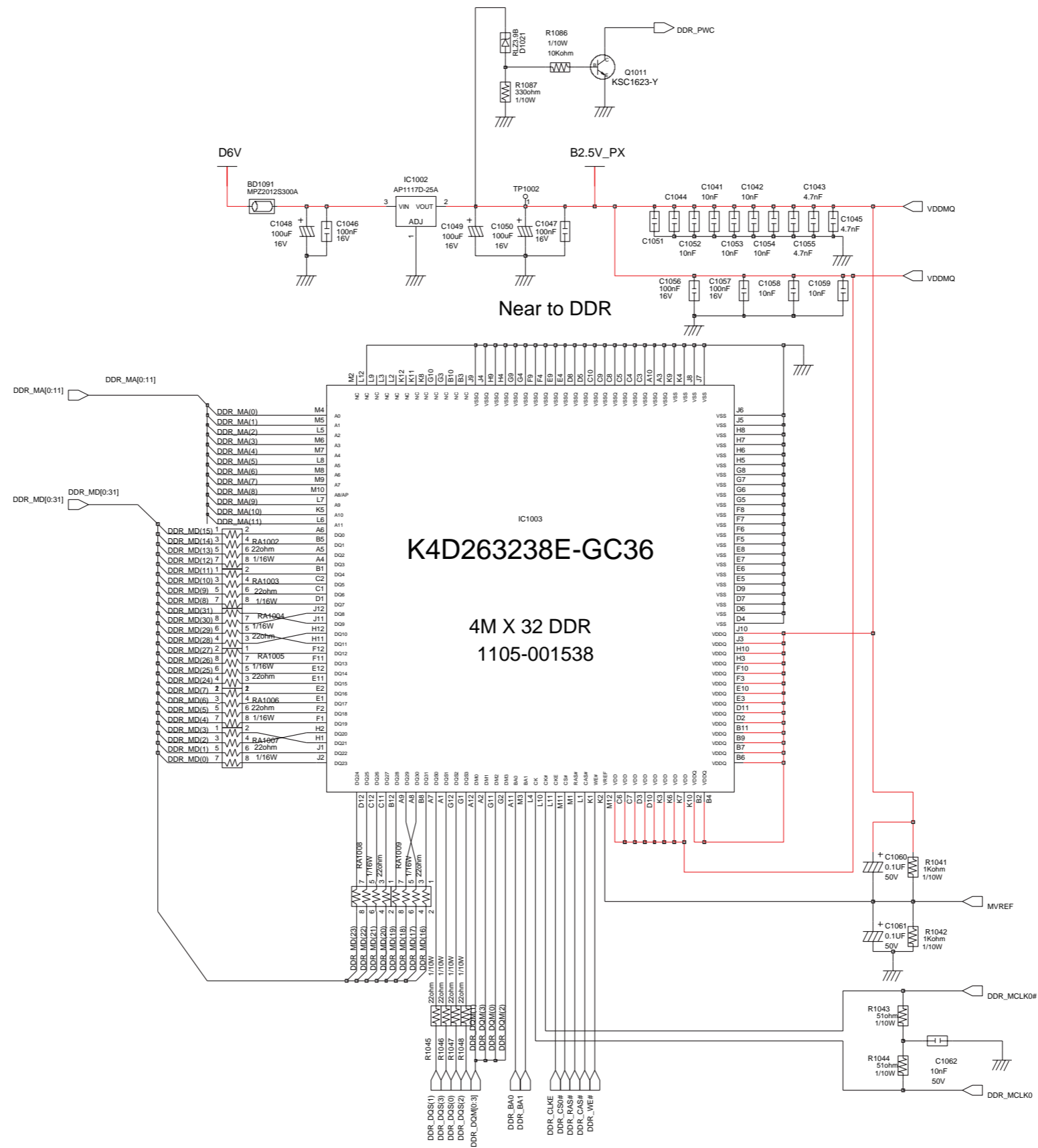

10-11 SVP-PX POWER BLOCK

This Document can not be used without Samsung's authorization.

	Power
	Signal

SVP_PX_POWER

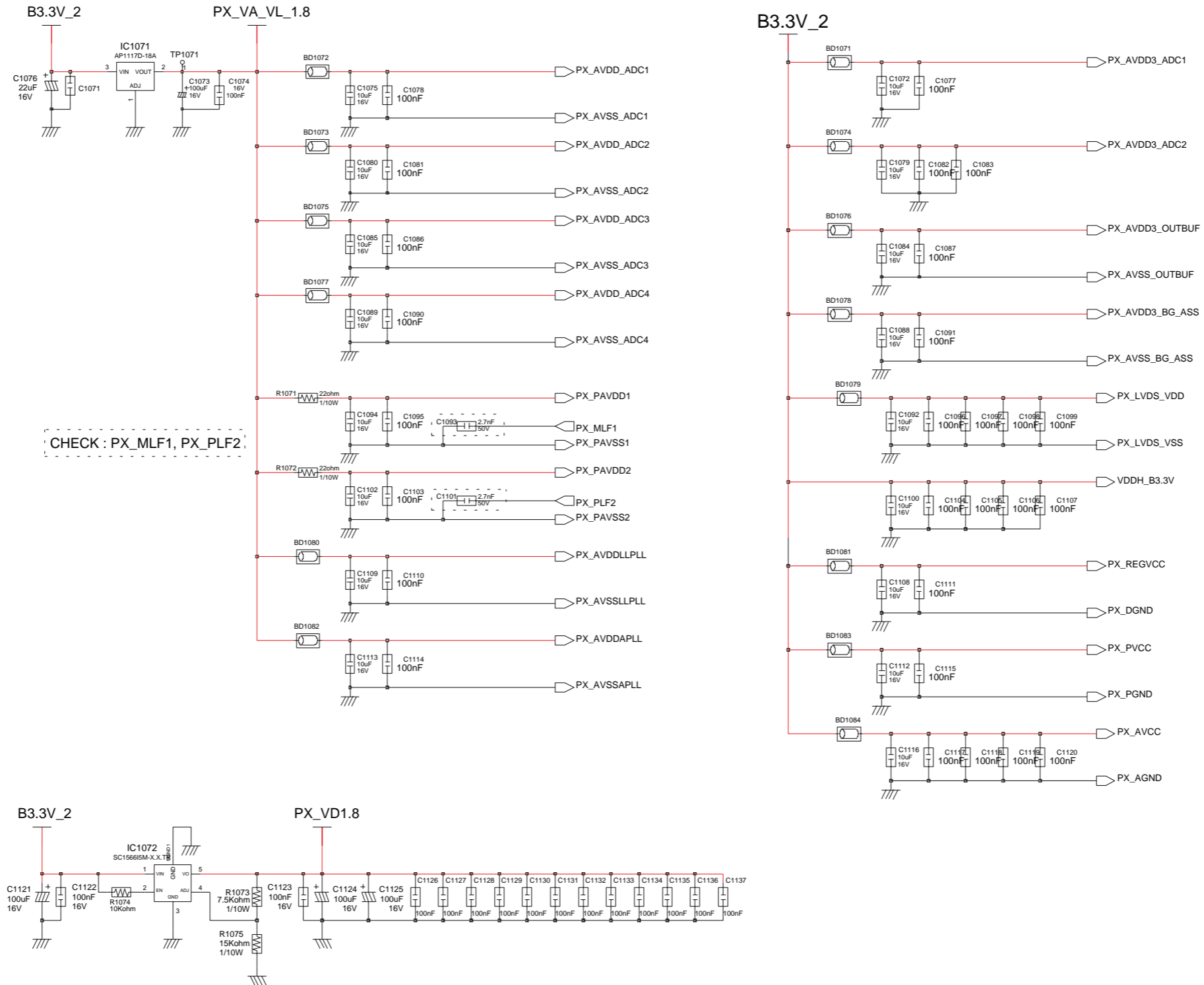

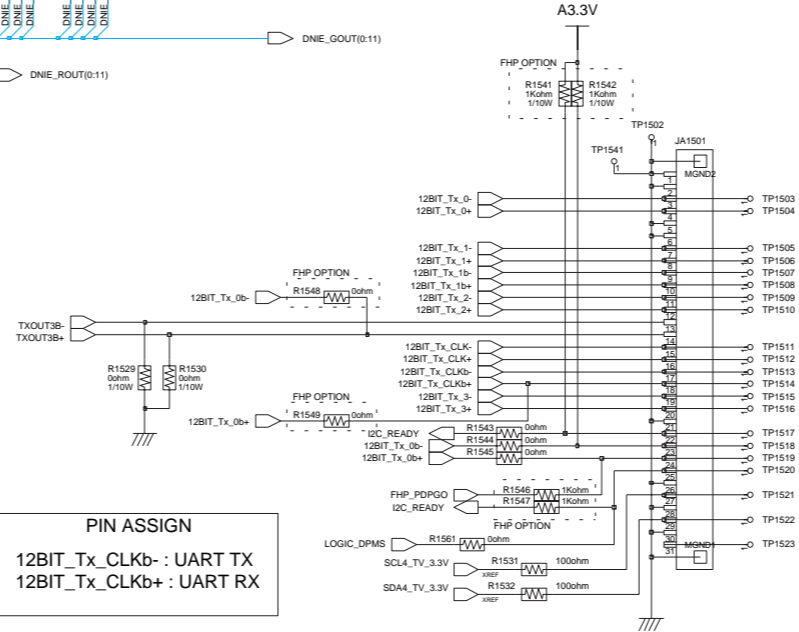
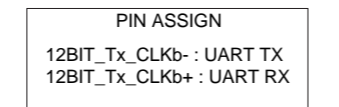
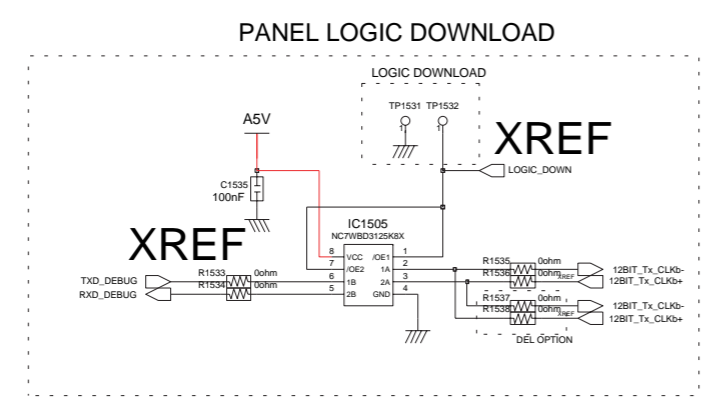
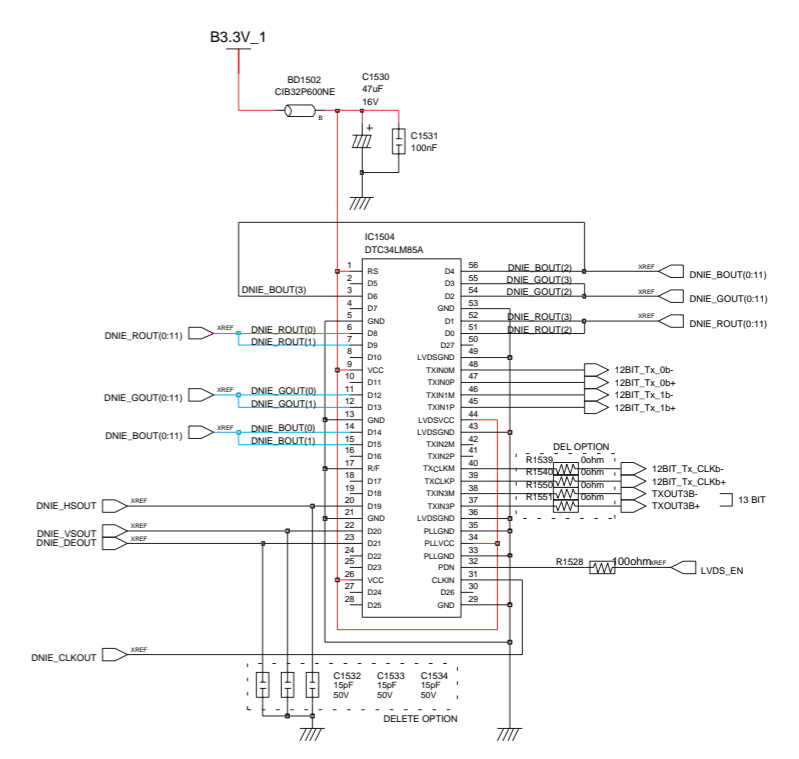
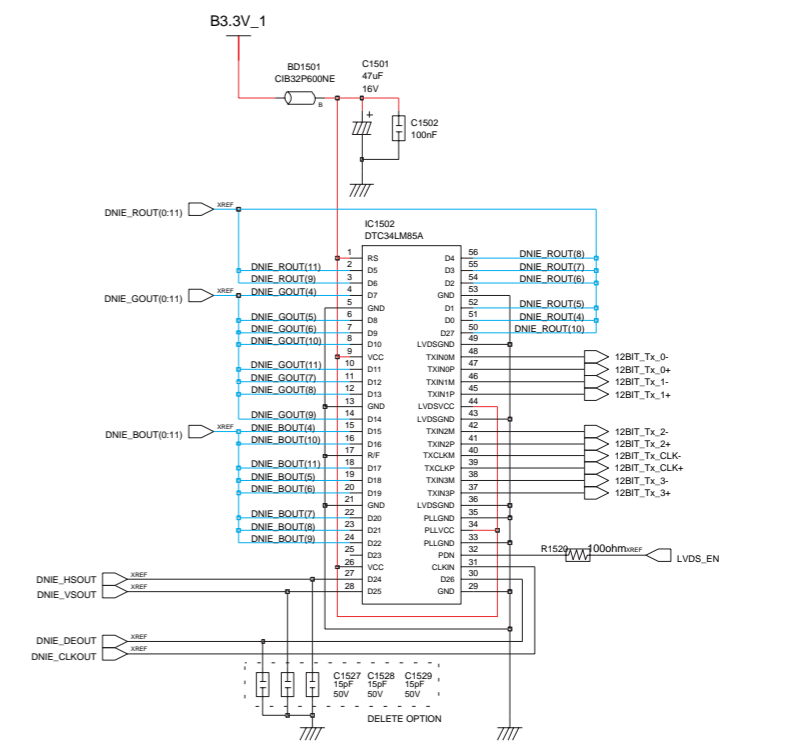
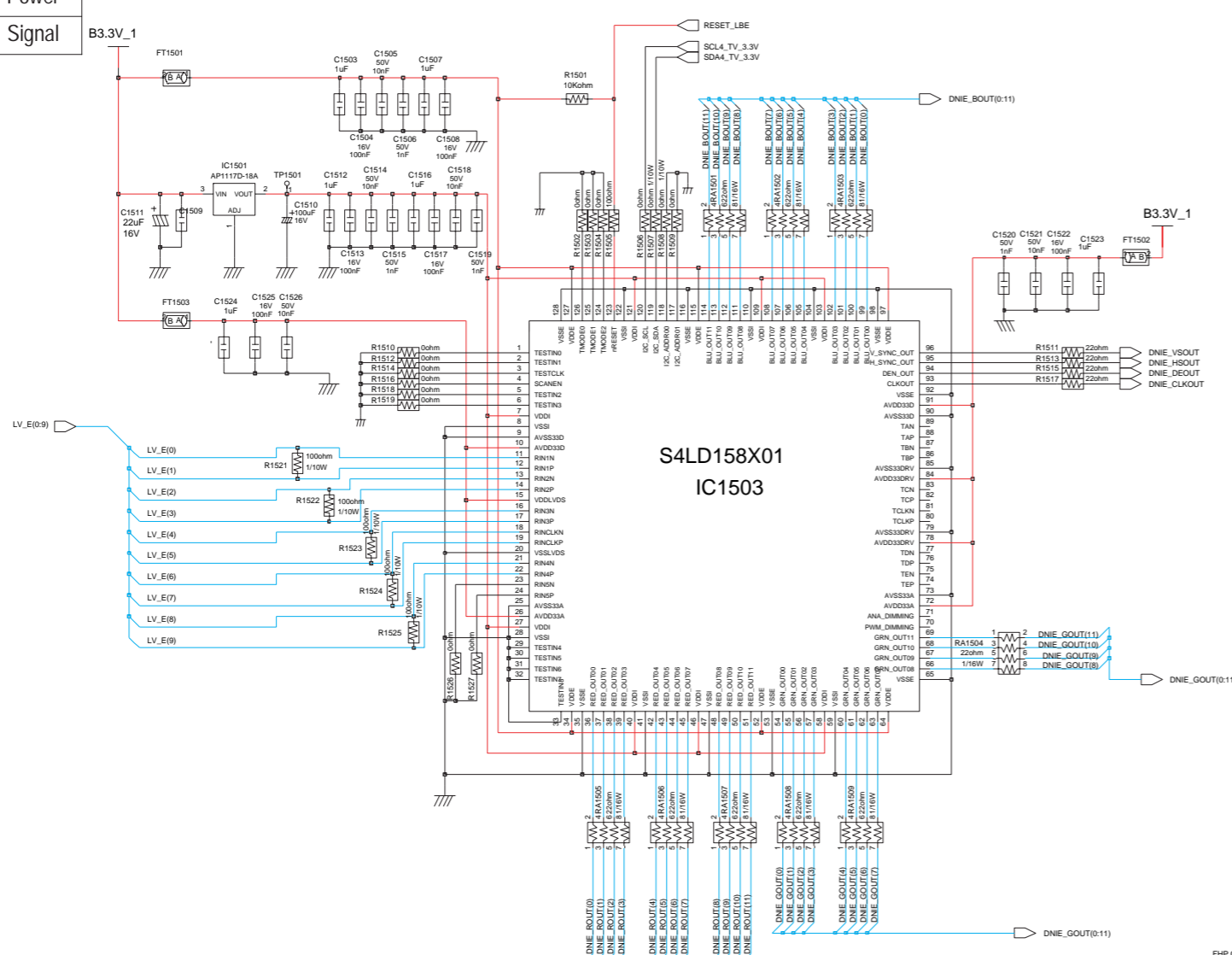
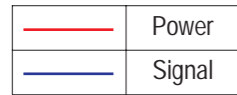

10-12 LBE & PWM CONTROL & PANEL I/F

This Document can not be used without Samsung's authorization.



10-13 LAKE (I2C & GPIO & USB & UART & INT)

This Document can not be used without Samsung's authorization.

	Power
	Signal

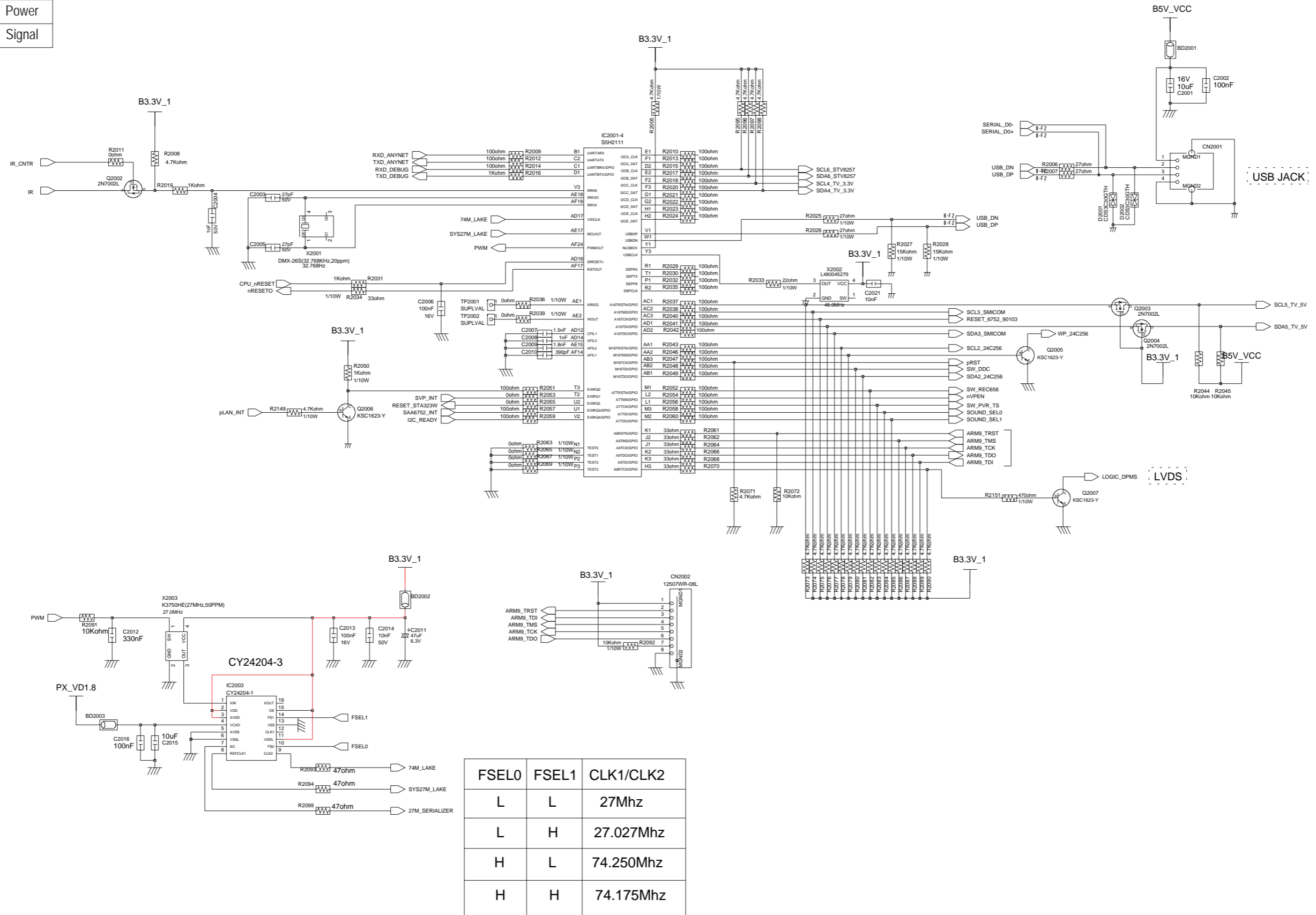

FSEL0	FSEL1	CLK1/CLK2
L	L	27Mhz
L	H	27.027Mhz
H	L	74.250Mhz
H	H	74.175Mhz

10-14 LAKE (I2S IN/OUT & TS-IN & YCbCr-OUT)

This Document can not be used without Samsung's authorization.

	Power
	Signal

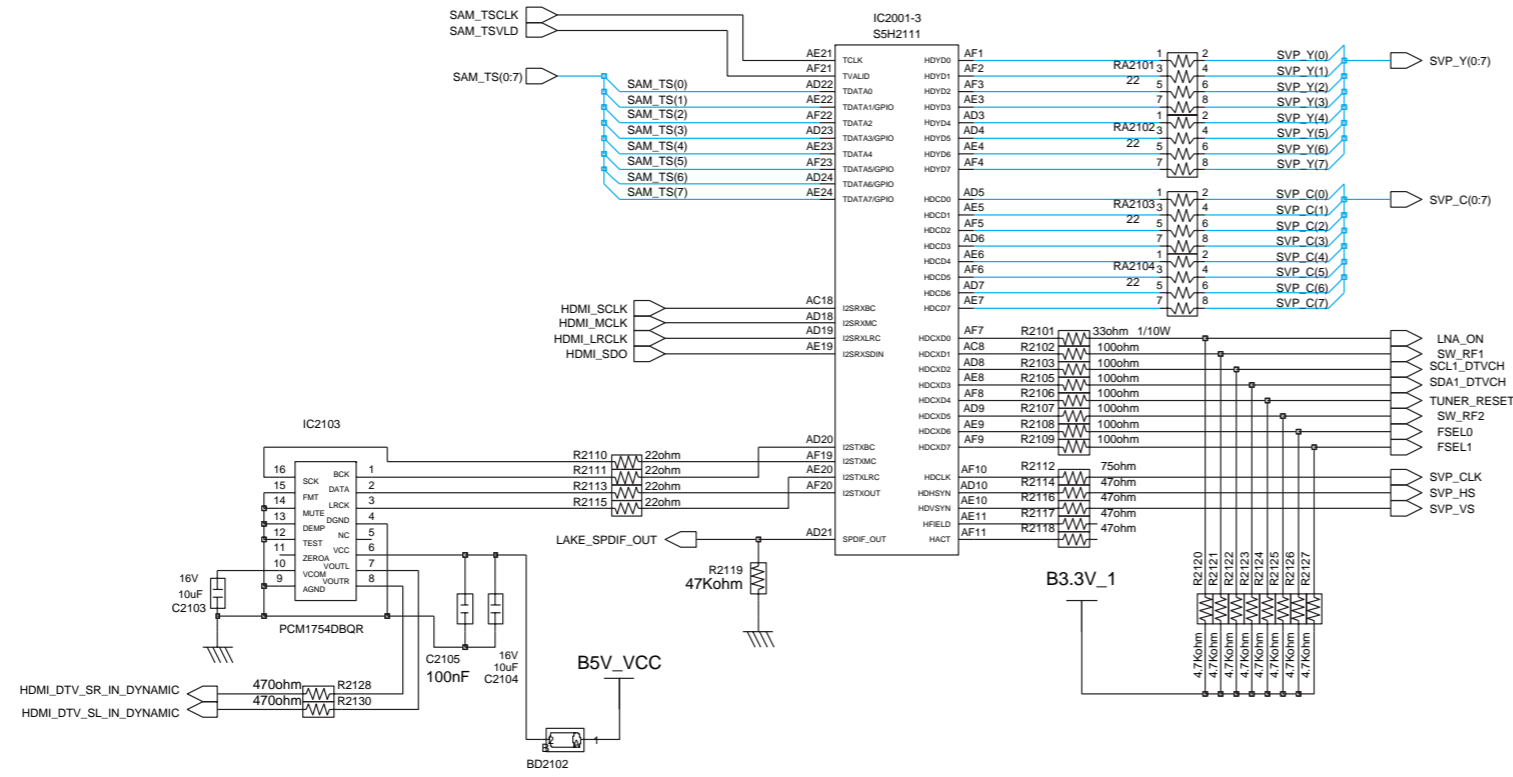

FOR PORSCHE

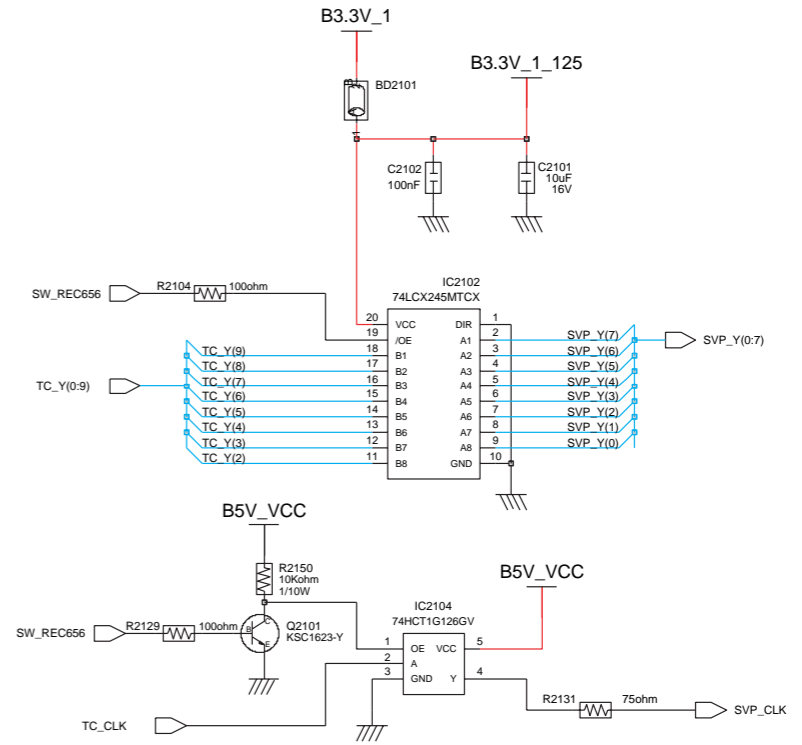

FOR DYNAMIC RANGE

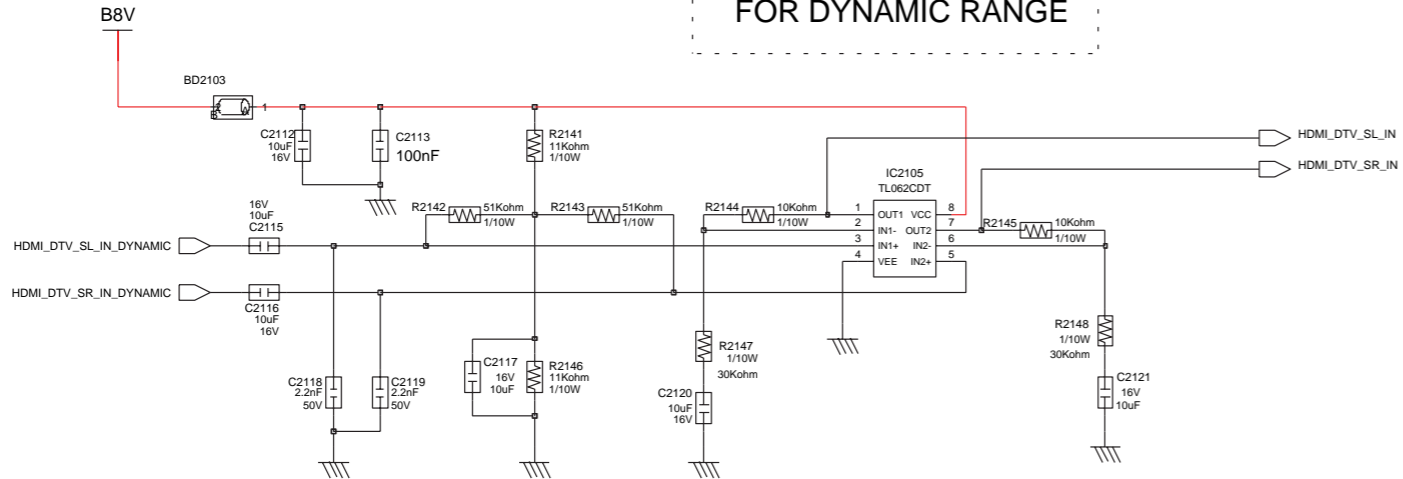

10-15 LAKE (DDR MEMORY)

This Document can not be used without Samsung's authorization.

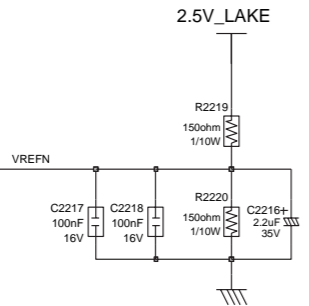
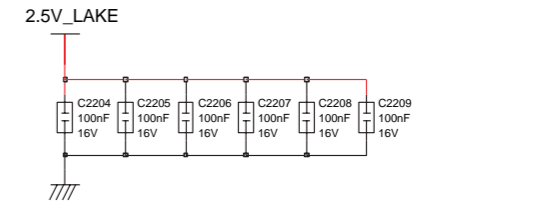
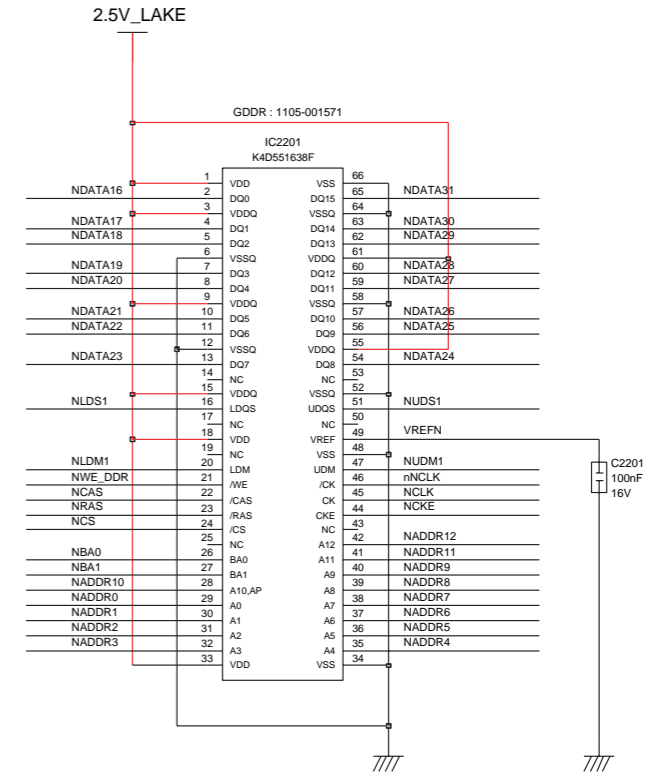
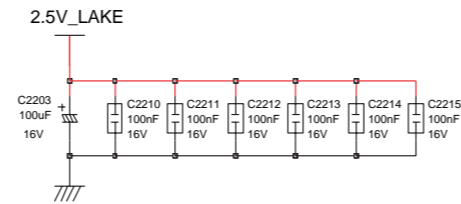
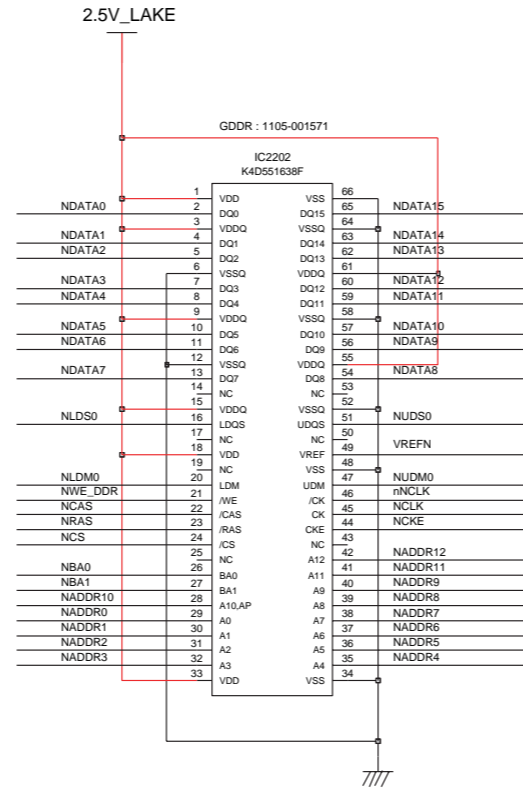
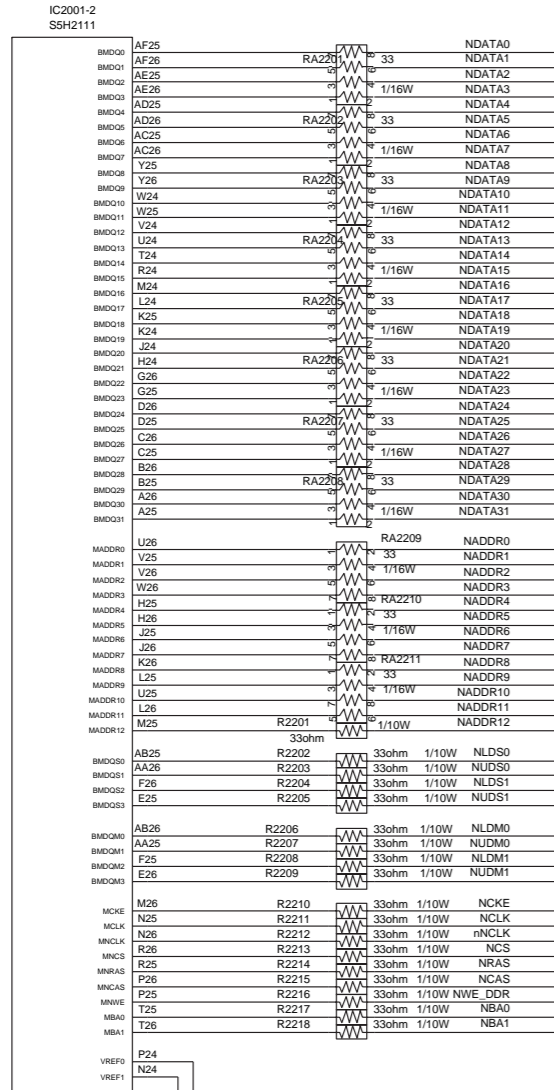
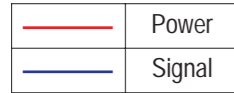

10-16 LAKE (STATIC MEMORY & DEBUG)

This Document can not be used without Samsung's authorization.

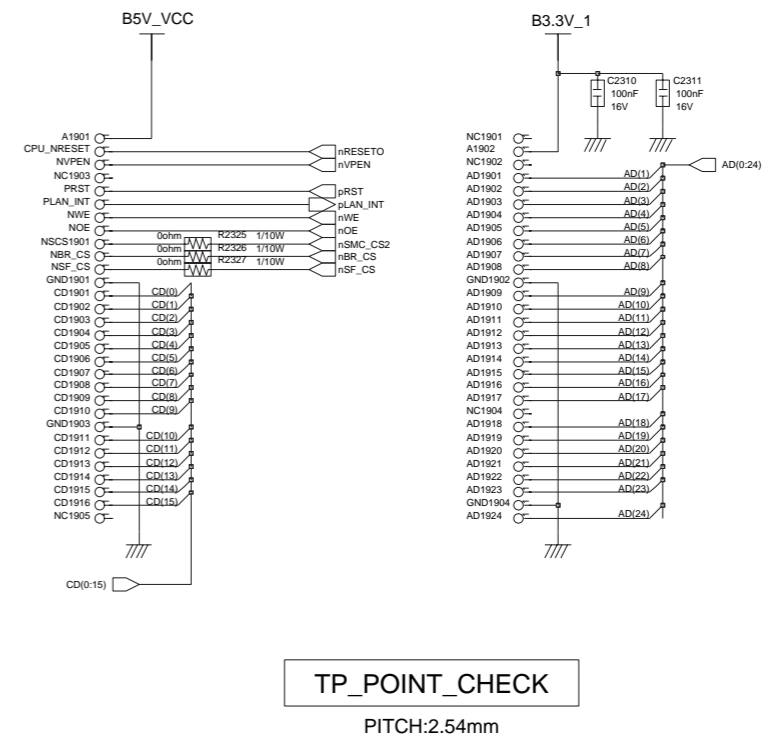
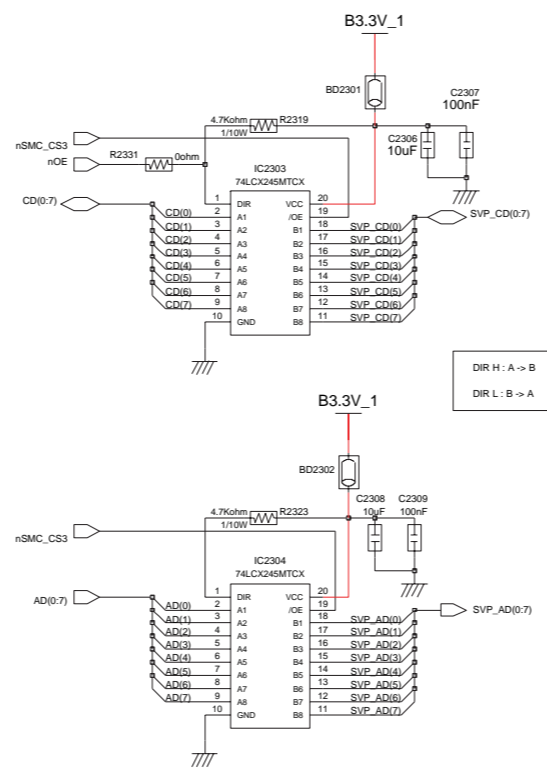
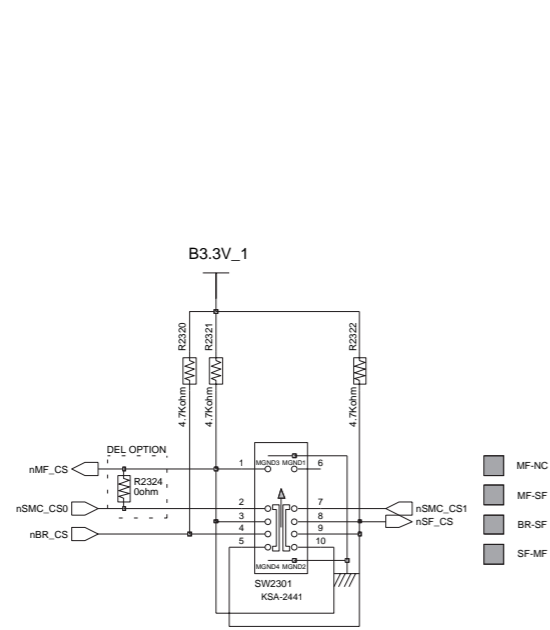
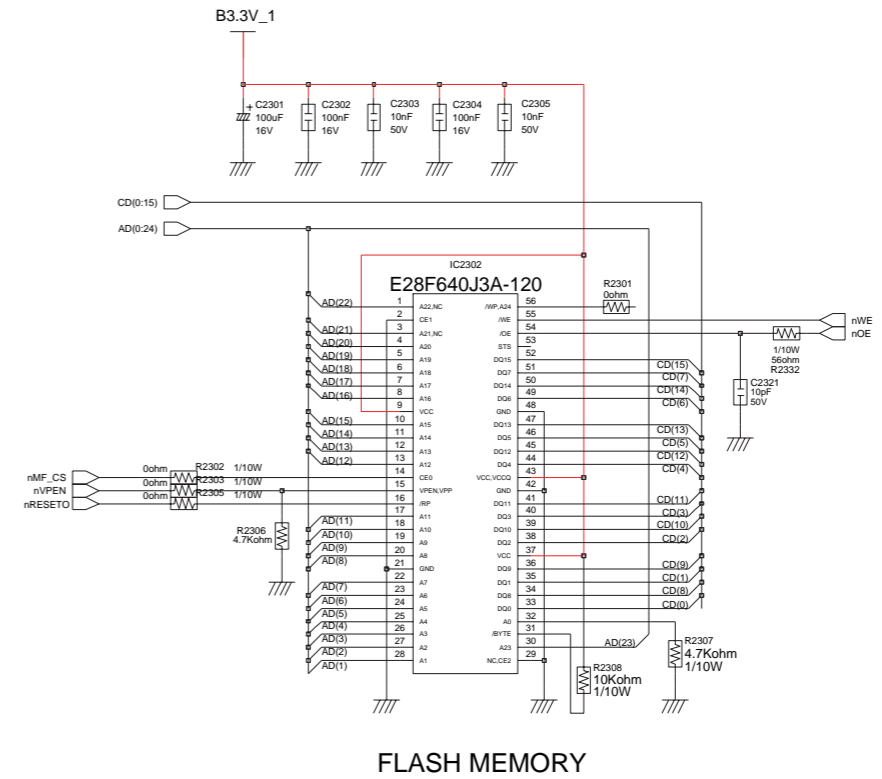
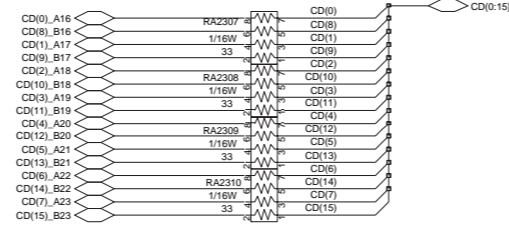
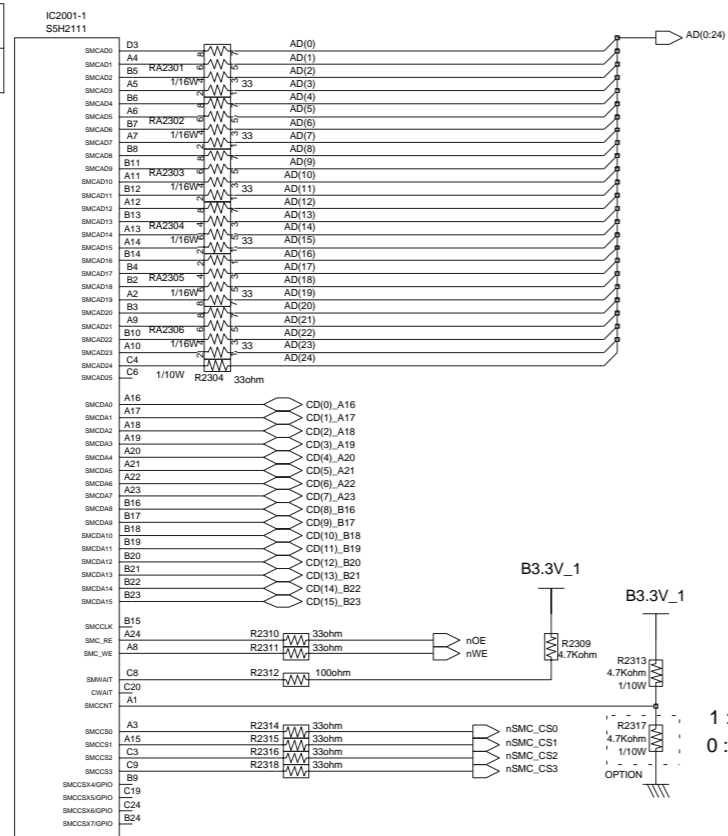
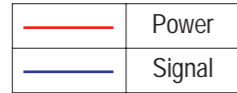

10-17 LAKE (POWER BLOCK)

This Document can not be used without Samsung's authorization.

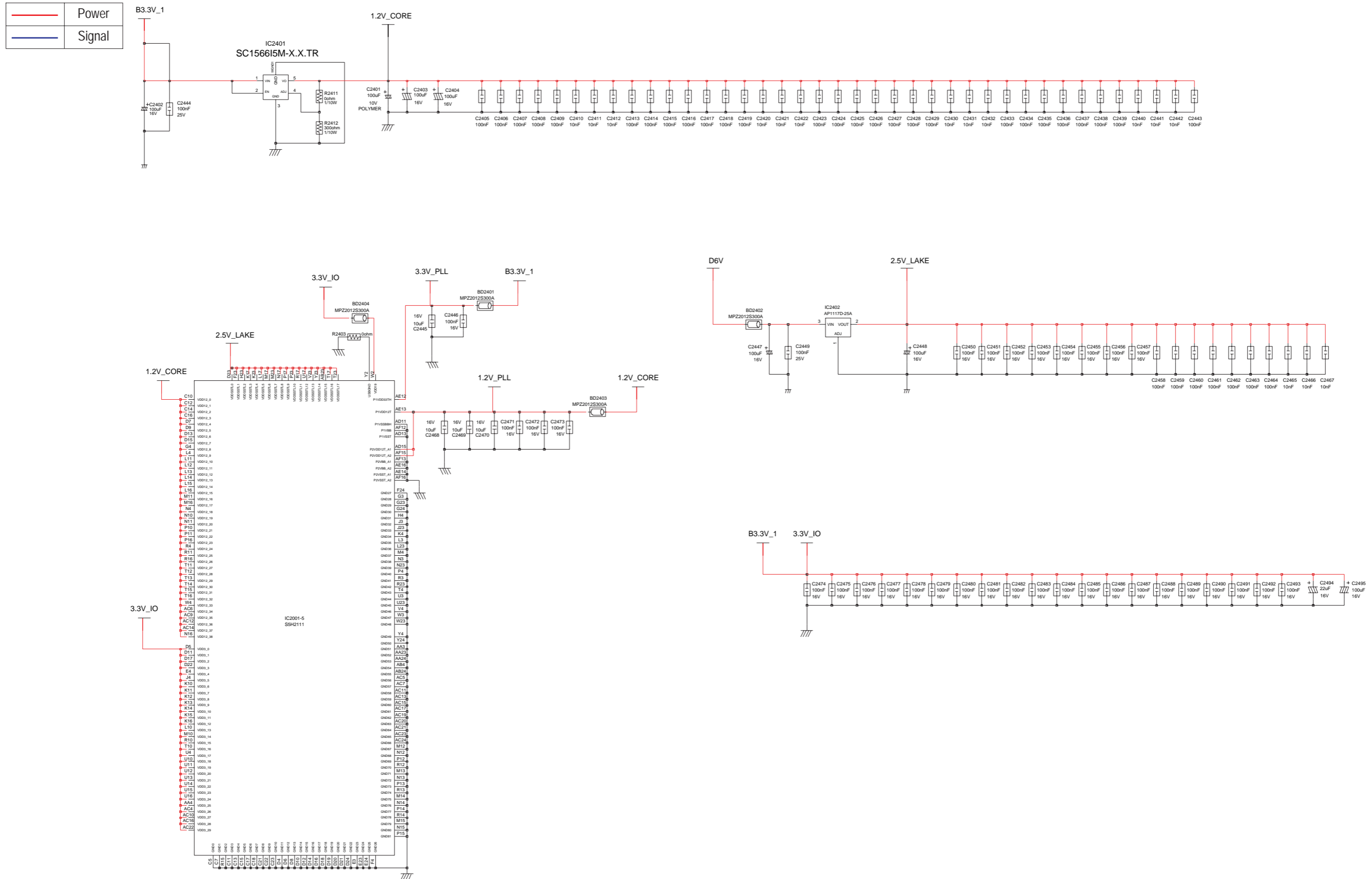

10-18 MPEG ENCODER (SAA6752)

This Document can not be used without Samsung's authorization.

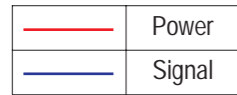

ONLY FOR PORSCHE

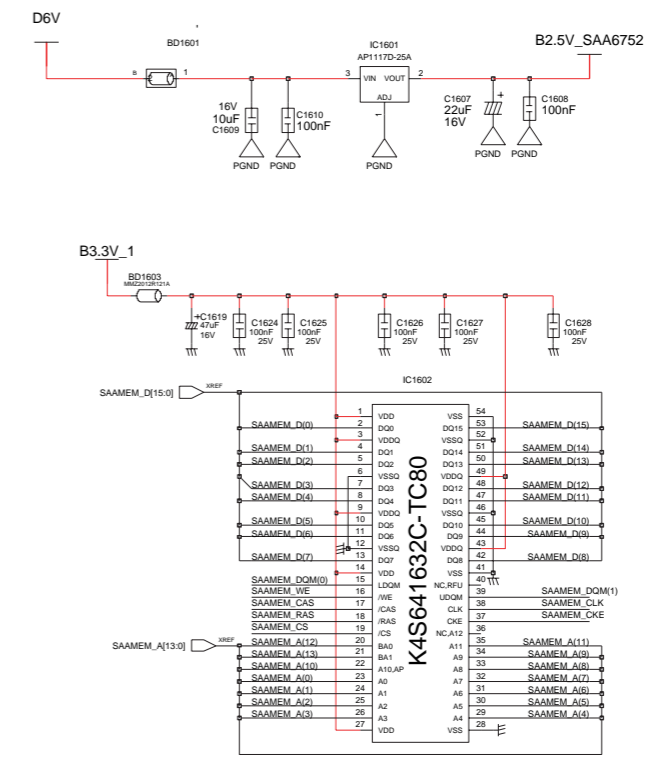
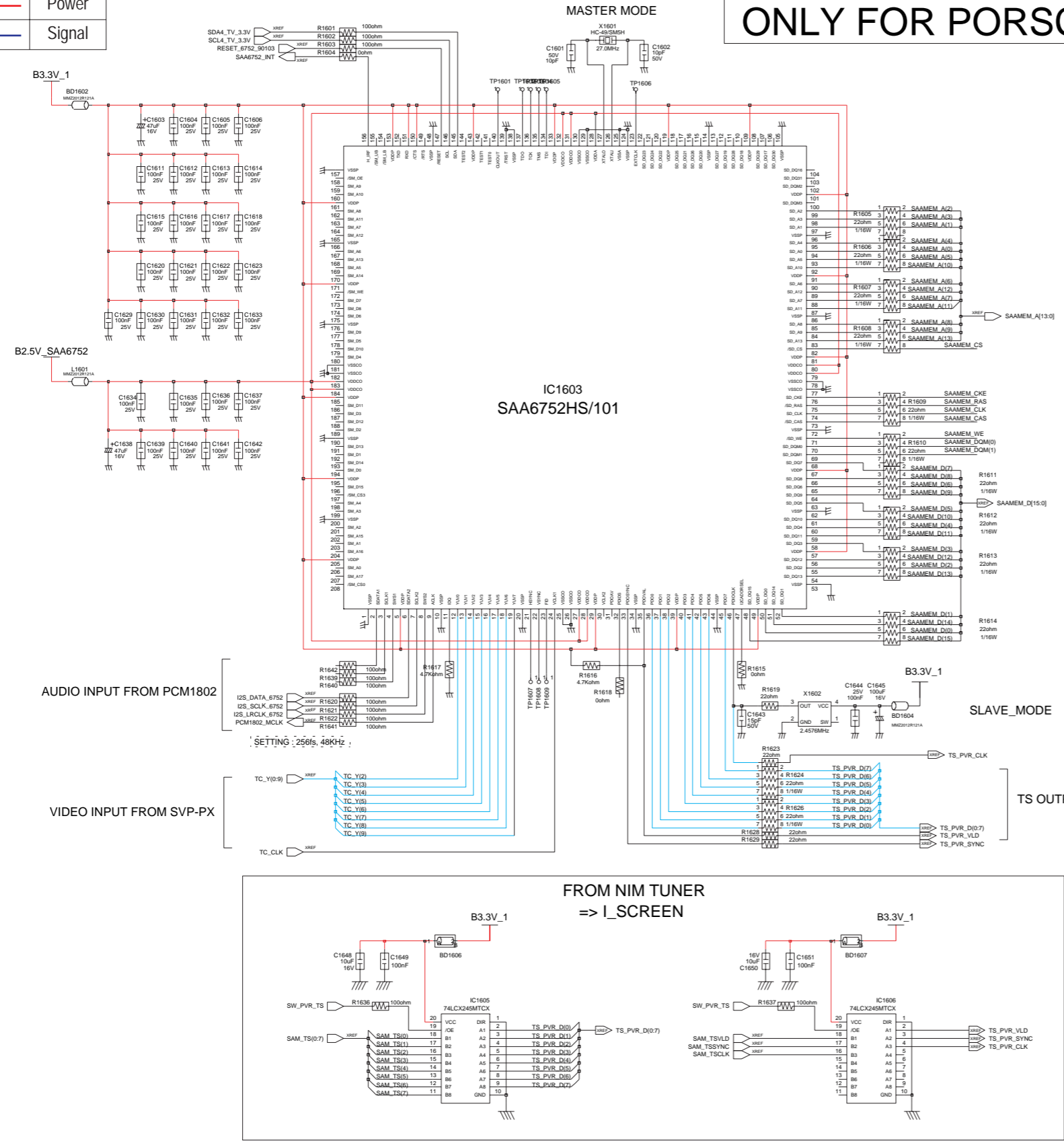

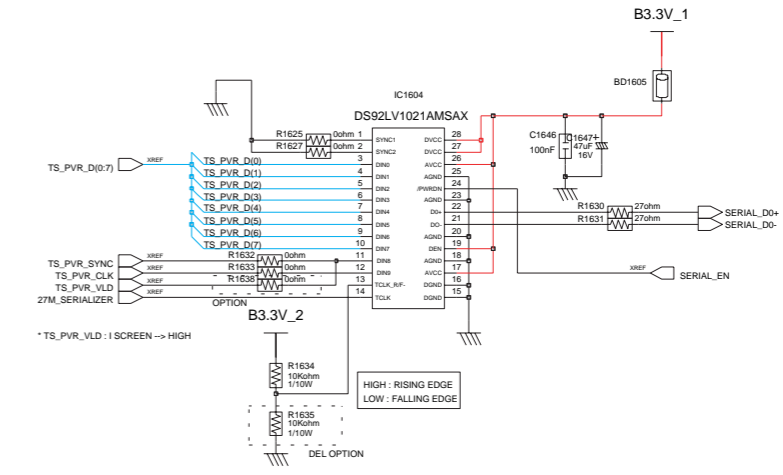

to I-SCREEN
(serializer)



10-19 TC90103AFG

This Document can not be used without Samsung's authorization.

	Power
	Signal

ONLY FOR PORSCHE

FROM TM BLCOK

Ext CVBS/YC INPUT

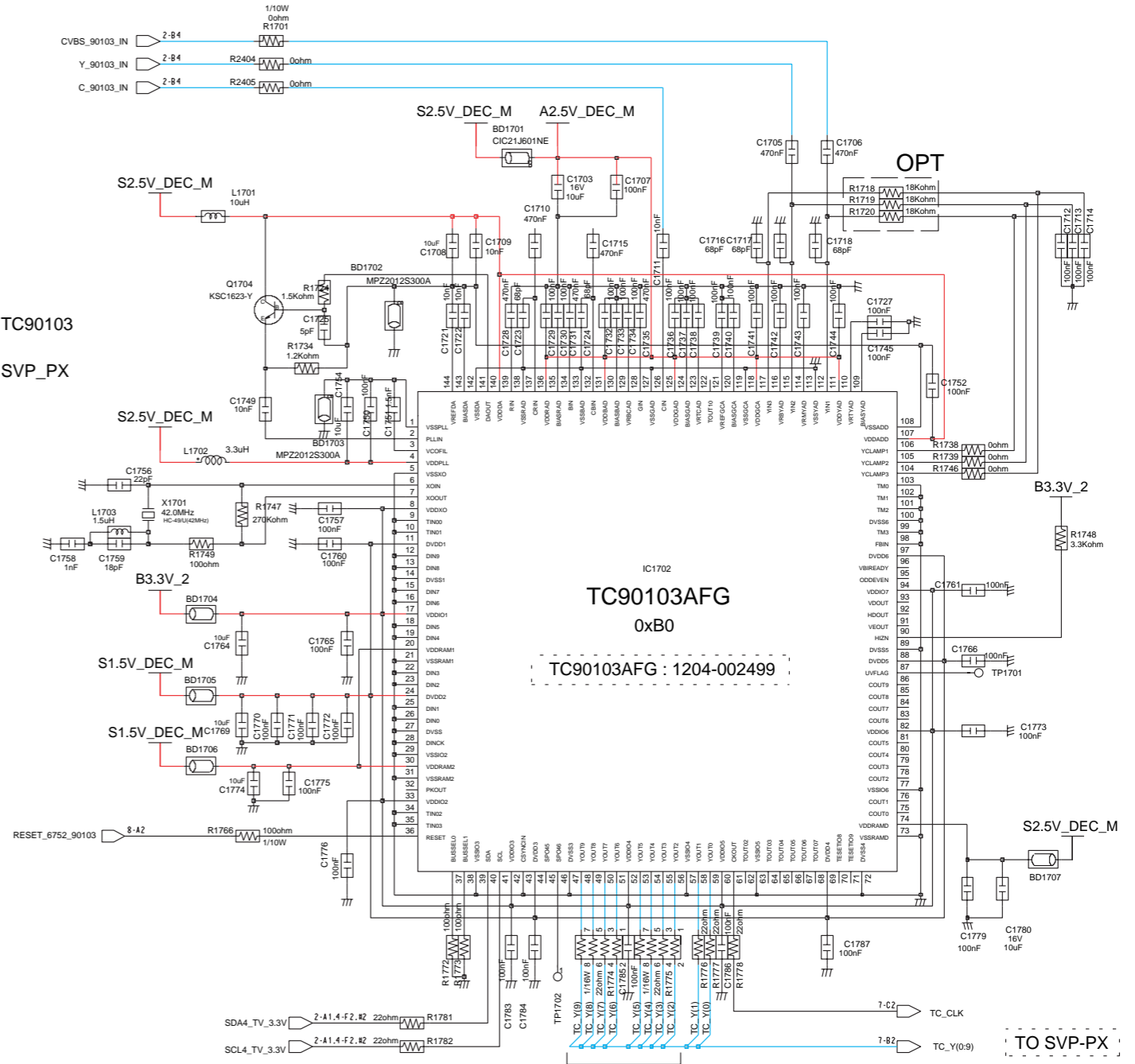
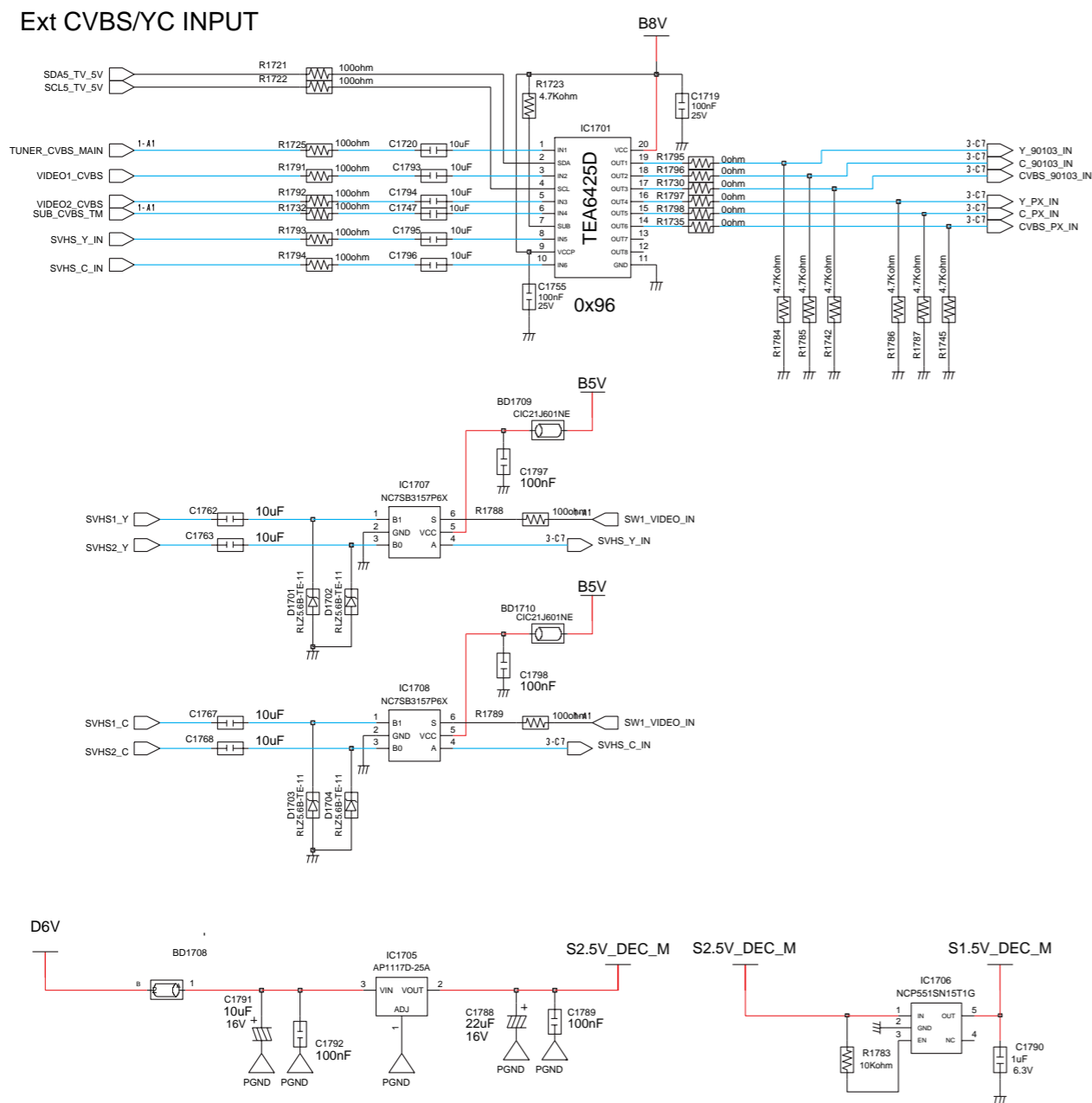

11. Operation Instruction & Installation

11-1 Product Features and Functions

11-1-1 Front Panel

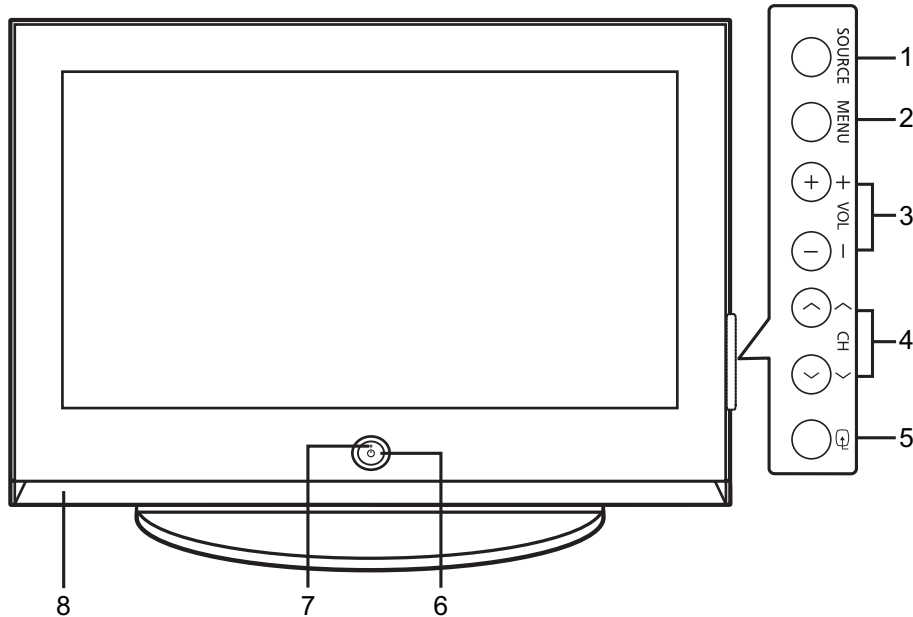

- | | |
|---|--|
| <p>1 SOURCE button
Press to display all of the available video sources (TV, AV1, AV2, S-Video1, S-Video2, Component1, Component2, PC, HDMI1, and HDMI2).</p> <p>2 MENU button
Displays the main on-screen menu.</p> <p>3 VOL +; buttons
Press to increase or decrease the volume. Also used to select or adjust items on the on-screen menu.</p> <p>4 CH(^, v) buttons
Press CH ^ or CH v to change channels. Also used to move up or down in the on-screen menu.</p> | <p>5  (Enter) button
Press to confirm a selection.</p> <p>6 Power button
Press to turn the TV on and off.

Power indicator
- Power Off : Blue
- Power On : Off</p> <p>7 Remote Control Sensor
Aim the remote control towards this spot on the TV.</p> <p>8 Speakers</p> |
|---|--|

11-1-2 Side of the TV & Rear Panel

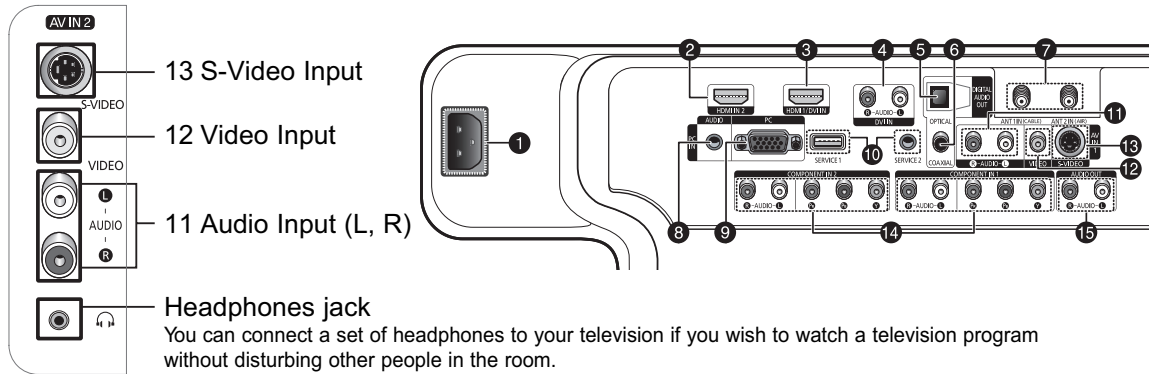

Note

- Prolonged use of headphones at a high volume may damage your hearing.

- | | |
|--|--|
| <p>1 POWER IN
Connect the supplied power cord.</p> <p>2 HDMI IN 2
Connect to the HDMI jack of a device with HDMI output.</p> <p>3 HDMI 1/DVI IN
Connect to the HDMI jack of a device with HDMI output.
These inputs can also be used as a DVI connection with separate analog audio inputs. An optional HDMI/DVI cable will be necessary to make this connection. When using the optional HDMI/DVI adapter, the DVI analog audio inputs on your TV allow you to receive left and right audio from your DVI device. (Not compatible with PC)</p> <p>4 DVI IN (AUDIO-L/R)
Connect to the DVI audio output jack of an external device.</p> <p>5 OPTICAL DIGITAL AUDIO OUT
Connect to a Digital Audio component.</p> <p>6 COAXIAL DIGITAL AUDIO OUT
Connect to a Digital Audio component.</p> <p>7 ANT 1 IN (CABLE)/ANT 2 IN (AIR)
75Ω Coaxial connector for Antenna/Cable Network.</p> | <p>8 PC AUDIO IN
Connect to the audio output jack on your PC.</p> <p>9 PC IN
Connect to the video output jack on your PC.</p> <p>10 SERVICE 1/SERVICE 2
This jack is for software upgrades.</p> <p>11 AUDIO-L/R (AV IN 1, 2)
Audio inputs for external devices, such as a camcorder or VCR.</p> <p>12 VIDEO (AV IN 1, 2)
Video input for external devices, such as a camcorder or VCR.</p> <p>13 S-VIDEO (AV IN 1, 2)
Video input for external devices with an S-Video output, such as a camcorder or VCR.</p> <p>14 COMPONENT IN 1, 2
Video (Y/P_B/P_R) and audio (L-AUDIO-R) component inputs.</p> <p>15 AUDIO OUT
Audio outputs for external devices.</p> |
|--|--|

Note

- Please be sure to match the color coded input terminals and cable jacks.

11-1-3 Remote Control

- 1 **POWER** button
Turns the TV on and off.
- 2 **Number buttons**
- 3 **-** button
Press to select additional channels (digital and analog) being broadcast by the same station. For example, to select channel "54-3", press "54", then press "-" and "3".
- 4 **ANTENNA** button
Press to select "Air" or "Cable".
- 5 **CH MGR** button
Used to displays Channel Lists on the screen.
- 6 **VCR, DVD control buttons**
Controls VCR tape or DVD disc functions: Rewind, Stop, Play/Pause, and Fast Forward.
- 7 **VOL (Volume) buttons**
Use it to adjust volume.
- 8 **MUTE** button
Press to mute the TV sound.
- 9 **MENU** button
Displays the main on-screen menu.
- 10 **ENTER** button
Confirms a selection.
- 11 **PIP** button
Activates picture in picture.
- 12 **INFO** button
Press to display information on the TV screen.
- 13 **Mode (TV/DVD/STB/CABLE/VCR) button**
Selects a target device to be controlled by the Samsung remote control (i.e., TV, DVD, STB, CABLE, or VCR).
- 14 **SOURCE** button
Press to display all of the available video sources(TV, AV1, AV2, S-Video1, S-Video2, Component1, Component2, PC, HDMI1, and HDMI2).
- 15 **PRE-CH** button
Tunes to the previous channel.
- 16 **E.SAVING** button
Press to adjust screen brightness according to surrounding environment.
- 17 **FAVCH** button
Press to switch between your favorite channels.
- 18 **CH (Channel) buttons**
Use it to switch channels.
- 19 **EXIT** button
Press to exit the menu.
- 20 **Up/Down/Left/Right buttons**
Control the cursor in the menu.
- 21 **SLEEP** button
Press to select a preset time interval for automatic shut off.

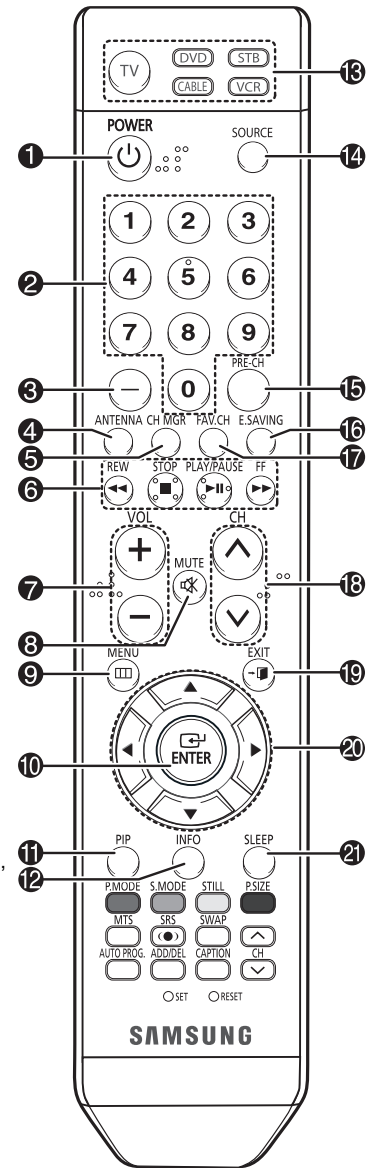

- 22 **P.MODE button**
Adjust the TV picture by selecting one of the preset factory settings (or select your personal, customized picture settings).
- 23 **S.MODE button**
Select Sound effect.
- 24 **MTS button**
Press to choose stereo, mono or Separate Audio Program (SAP broadcast).
- 25 **SRS button**
Activates TruSurround.
- 26 **AUTO PROG. button**
Press to display the memorized channels menu.
- 27 **ADD/DEL button**
Press to add or erase channels in the TV's memory.
- 28 **STILL button**
Press to pause the current screen.
- 29 **P.SIZE button**
Select Picture size.
- 30 **PIP control buttons**
SWAP: Interchange the main and sub picture.
CH (▲, ▼): Displays the available channels in sequence.
(These buttons change channels in the PIP window only.)
- 31 **CAPTION button**
Controls the caption decoder.
- 32 **RESET button**
If your remote control is not functioning properly, take out the batteries and press the reset button for about 2~3 seconds.
Re-insert the batteries and try using the remote control again.
- 33 **SET button**
Used during set up of this Samsung remote control, so that it will work compatibly with other devices (VCR, Cable Box and DVD).

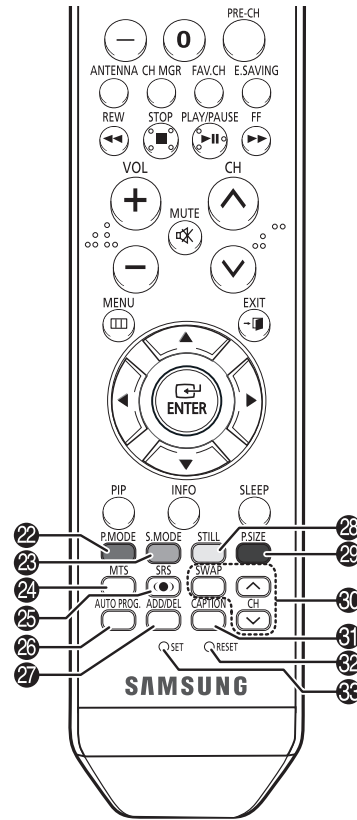

11-2 New Features

11-2-1 Dynamic Contrast

- Reproducing optimized contrast and color by automatically detecting the characteristics. (Off/On)

- OSD Operation Tree

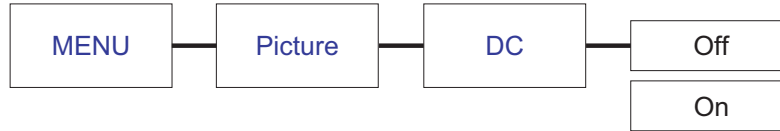

- Image change with Dynamic Contrast



DC Off



DC On

→ When the DC function is On, the contrast ratio is enhanced dynamically and statically according to the range on the screen, the dark area to be darker and the bright area to be brighter.

▶ DC Operation Mode and Release Requirement

1) Operating Modes

Source	RF	AV	S_video	Comp_1	Comp_2	HDMI	DVI	PC
Operation	⊙	⊙	⊙	⊙	⊙	⊙	⊙	⊙
Detail Operation	- PC / DNle Off : DC Off (OSD Inactive) - DVI DTV : DC On							

2) Release Requirement (Factory Reset)

- DC Function : On

11-2-2 Power Saving

- Sensing the outside brightness and controlling brightness with the Ray Sensor. (Off/On)

- OSD Operation Tree

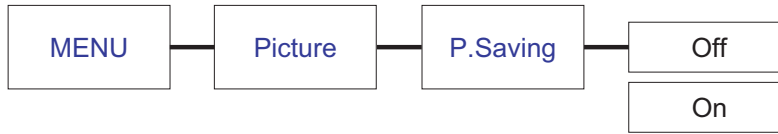

- Image change with Power Saving



P.Saving Off



P.Saving On

→ When turn the Power Saving function On, control the screen luminance with 8 Step changing width at the standard of 150 Lux. (The luminance of average house is 200 ~ 250 Lux.)

▶ Power Saving Operation Mode and Release Requirement

1) Operating Modes

Source	RF	AV	S_Video	Comp_1	Comp_2	HDMI	DVI	PC
Operation	◎	◎	◎	◎	◎	◎	◎	◎
Detail Operation	- All Modes Operation							

2) Release Requirement (Factory Reset)

- BS Function : Off

11-3 Installation Notes and Precautions

11-3-1 Installation Notes

1. Contact a professional installation service to install the wall bracket.
2. Samsung Electronics is not responsible for any damages to the product or harm to customers when the installation is done by the customer.
3. This product is for installing on cement walls. The product may not stay in place when installed on plaster or wood.
4. Connect all external devices prior to installing the wall bracket.
5. The package contents and parts supplied for the wall mount are subject to change without prior notice.

11-3-2 Parts (Wall attachment panel is sold separately)

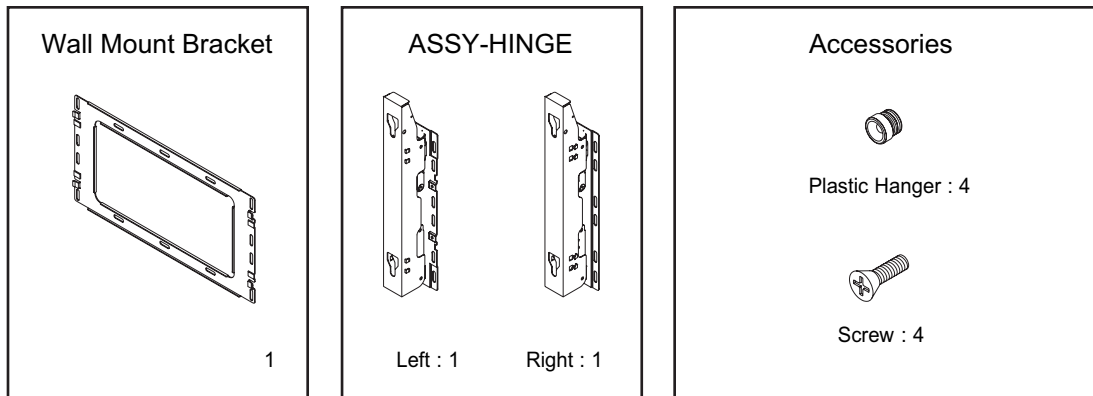

11-3-3 How to assemble the Wall Mount Bracket

- 1** The wall mount bracket is delivered separately. Please tighten the captive screw in the direction of the arrow after assembling the bracket.
Install the Wall Mount Bracket after the screws are securely inserted into the wall.

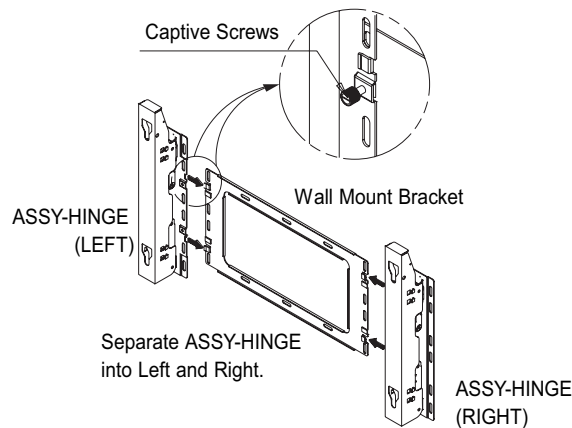

11-3-4 Fixing the TV panel to the wall attachment panel bracket

1 Remove the screws from the back of the PDP.

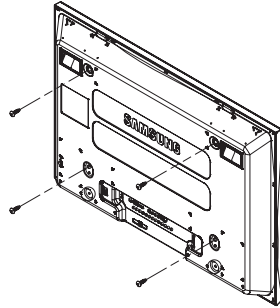

2 Use the screw and assemble the plastic hanger. (Please refer to the following picture.)



- Please ask the installers to install the wall mount bracket.
- Please be sure to check if the plastic hanger is completely secured on both the left and right side after hanging the SET on the wall mount bracket.
- Please avoid catching your fingers while installing and adjusting the angle.
- Please tightly secure the wall mount bracket to the wall to avoid injury from a falling SET.

3 Tighten the screws of the plastic hanger (shown in picture 2) to the back side of the PDP.

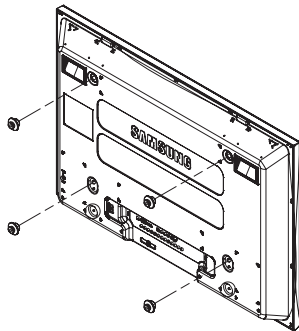

4 Remove the Safety Pins. Fasten the 4 plastic latches assembled at step (3) on the back side of the PDP using the guide holes of the wall mount, push (1) and hook (2) down to secure the PDP on the wall mount as illustrated. Secure the PDP by inserting the Safety Pins, not to fall from the wall mount.

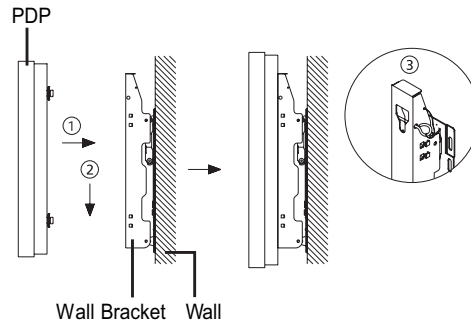

11-3-5 How to Adjust Mounting Angle

Note : Please secure the mounting bracket on the wall surface after setting its angle at 0°

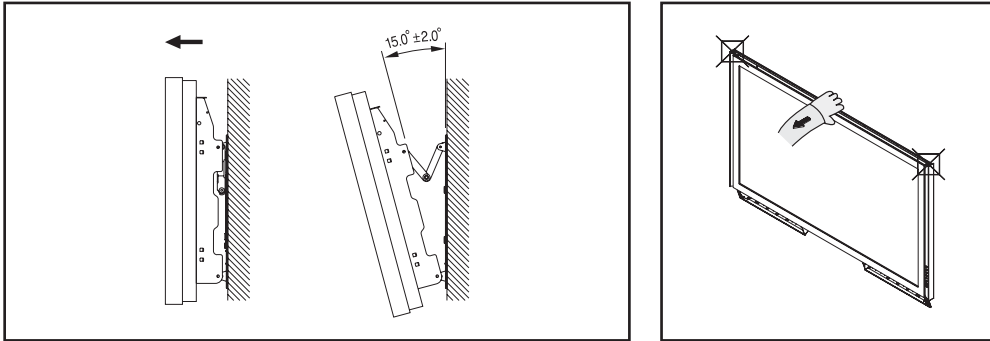

1. Secure the SET to the wall mount bracket.
(Please refer to the following instructions.)
2. Set the angle by pulling the upper end of the SET attached to bracket in the direction of the arrow.
(Refer to the illustration on the right.)
3. The angle can be adjusted from 0° to 15° by $\pm 2^\circ$.

Hold onto the middle of the PDP to adjust the angle (not the sides of the PDP).

11-3-6 Connecting External Devices to the PDP

Note : To connect external devices such as a DVD or a Home Theater System to the PDP, please refer to following instructions:

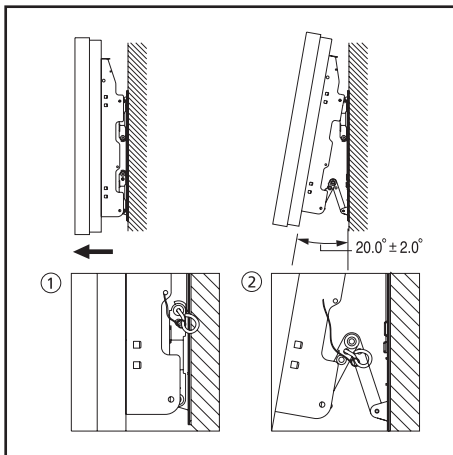

1. Be sure to remove the safety pins underneath the PDP.

Note : If the safety pins are not removed, the angle cannot be adjusted. Any attempt to do so may cause damage to the PDP.

2. Hold onto the bottom of the PDP and pull forward fully as directed by the arrow as illustrated) to adjust the angle. (0°~20° by 2°) Insert the Safety Pins to the front guide holes on both sides as illustrated in figure ②.

Note : Viewing the PDP after connecting the external devices Remove the Safety Pins to adjust the angle to 0°, and then secure the Safety Pins again.

- For safety, be sure to secure the PDP using the safety pins. If the safety pins are not used, the PDP may fall, causing serious injury.

11-3-7 How to assemble the Stand-Base

- 1 Using the 4 screws for securing the stand pegs and the monitor, firmly attach the monitor to the stand pegs. (The exterior of the set may be different than the picture.)

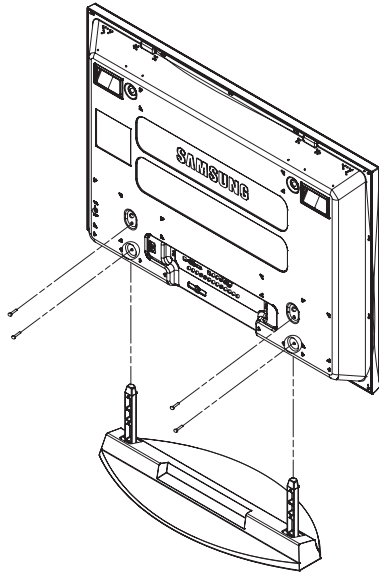

Warning

Firmly secure the stand to the TV before moving it, as the stand may fall and could cause serious injury.

- Two or more people should carry the TV. Never lay the TV on the floor because of possible damage to the screen. Always store the TV upright.

12. Disassembly & Reassembly

12-1 Overall Disassembly & Reassembly

△ Notice

- Be sure to separate the power cord before disassembling the unit.
- Discharge the capacitors first when separating PCB's with high capacity capacitors such as SMPS, X Main Board, Y Main Board, etc. (A spark may be generated by the electric charge, and there is danger of electronic shock.)
- Check that the cables are properly connected referring to the circuit diagram when disassembling or assembling the unit taking care not to damage the cables.
- Take care not to cause a flaw in the Glass Filter in the front.
- Assemble the boards in the reverse order of the disassembly.
- The plasma must be layed down on a flat padded surface for disassembly and reassembly.

12-1-1 Separation of ASSY STAND P-BASE

Part Name	Description	Description Photo
Stand	<p>① Remove 4 screws. : PH,+,WSP,S,M4,L35,ZPC(BLK)</p> <p>② Pull the ASSY STAND P-BASE down to remove it from the unit.</p> <p>△: Please lay the PDP unit face down on a soft surface when removing the stand.</p>	

12-1-2 Separation of ASSY COVER P-REAR

Part Name	Description	Description Photo
Cover Rear	<p>① Remove 4 screws. (□) : M8,L16,ZPC(BLK),SWRCH18A,WP0</p> <p>② Remove 14 screws. (○) : BH,+,B,M4,L12,ZPC(BLK)</p> <p>③ Remove 4 screws. (○) : BH,+,S,M4,L10,ZPC(BLK)</p> <p>④ Remove the ASSY COVER REAR.</p>	

12-1-3 Separation of ASSY BRACKET P-TERMINAL

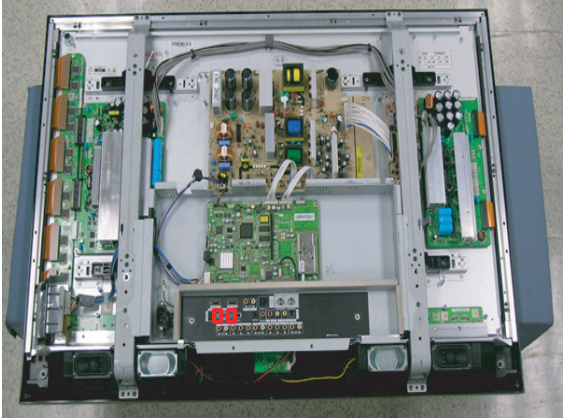
Part Name	Description	Description Photo
Bracket Terminal	<ol style="list-style-type: none"> ① Remove the 2 Hex nuts for the PC input. : #4-40,L6,NI PLT,C3601,- ② Remove Bracket Terminal. 	

12-1-4 Separation of ASSY PCB MISC-MAIN

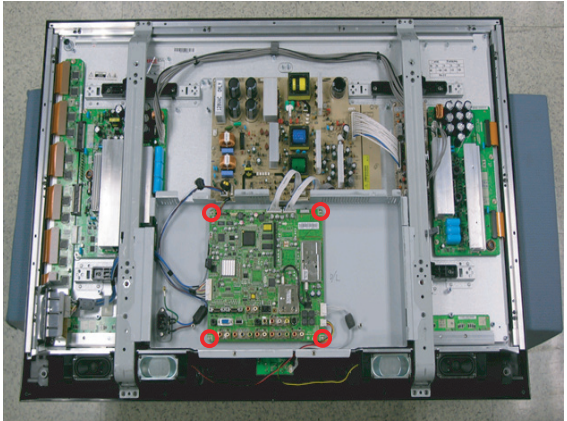
Part Name	Description	Description Photo
Main Board	<ol style="list-style-type: none"> ① Detach all connectors from the Main Board. ② Remove 4 screws. : PH,+,WWP,M3,L8,NI PLT ③ Remove the Main Board. 	

12-1-5 Separation of FILTER-EMI AC LINE

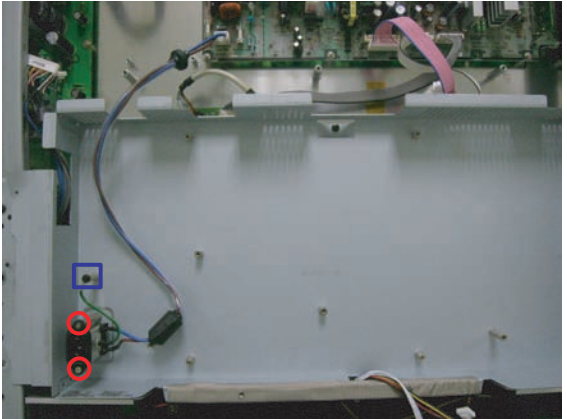
Part Name	Description	Description Photo
Filter-EMI AC LINE	<ol style="list-style-type: none"> ① Detach connector from Main SMPS. ② Remove 2 screws. : PH,+,WWP,M3,L8,NI PLT ③ Remove a screw. : BH,+,S,M4,L10,ZPC(BLK) ④ Remove FILTER-EMI AC LINE. 	

12-1-6 Separation of BRACKET-PCB

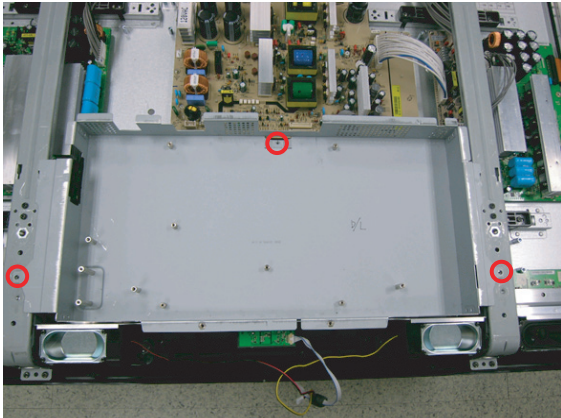
Part Name	Description	Description Photo
Bracket PCB	<ol style="list-style-type: none"> ① Remove 3 screws. : BH,+,S,M4,L10,ZPC(BLK) ② Remove the BRACKET-PCB. 	

12-1-7 Separation of ASSY BOARD P-SIDE AV

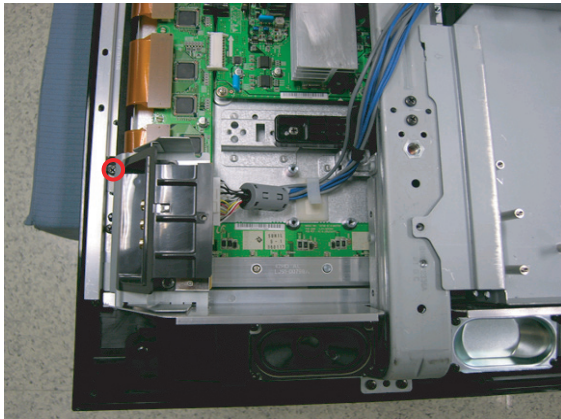
Part Name	Description	Description Photo
Side AV	<ol style="list-style-type: none"> ① Remove 1 screw. : BH,+,S,M4,L10,ZPC(BLK) ② Remove the Side AV assy. 	

12-1-8 Separation of ASSY BRACKET P-WALL

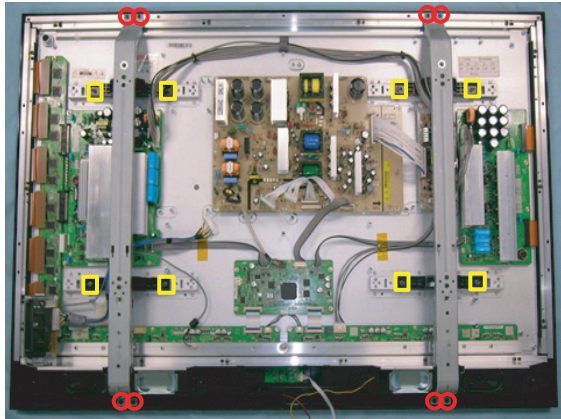
Part Name	Description	Description Photo
Wall Bracket	<ol style="list-style-type: none"> ① Remove 8 screws. : BH,+,B,M4,L12,ZPC(BLK) ② Remove 16 screws. : BH,+,S,M4,L10,ZPC(BLK) ③ Remove Wall Bracket. <p>⚠: Please lay the PDP panel face down on a soft surface when separating front cover.</p>	

12-1-9 Separation of ASSY SPEAKER P

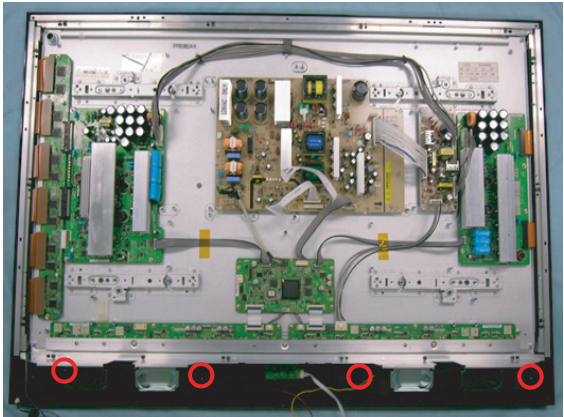
Part Name	Description	Description Photo
Speaker	① Remove 4 screws. : BH,+,WP,B,M4.0,L12,ZPC(BLK),SWRCH18A,- ② Remove the Speaker.	

12-1-10 Separation of ASSY BOARD P-POWER&IR

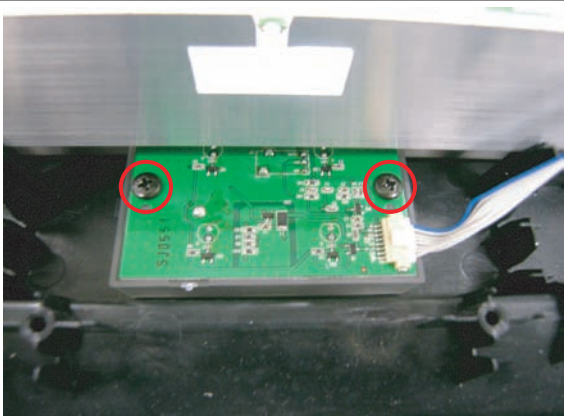
Part Name	Description	Description Photo
Power & IR Board	① Remove 2 screw. : BH,+,-,S,M4,L8,ZPC(BLK) ② Remove the Power & IR Board.	

12-1-11 Separation of ASSY PCB P-SMPS & SMPS DC-DC

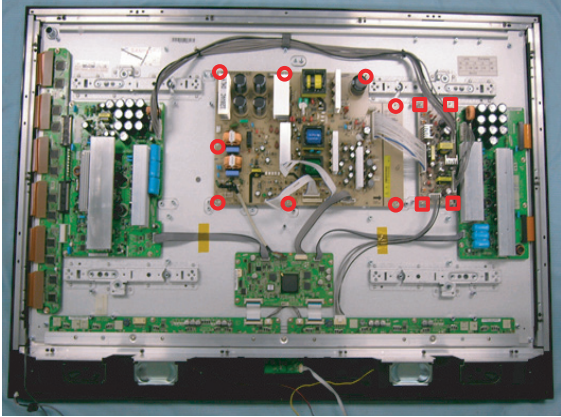
Part Name	Description	Description Photo
SMPS & SMPS DC-DC Board	<ol style="list-style-type: none"> ① Detach all connectors from the Assy PCB P-SMPS. ② Remove 8 screws. : PH,+,WWP,M3,L8,NI PLT ③ Remove the Assy SMPS PCB. ④ Detach all connectors from the Assy SMPS DC/DC Board. ⑤ Remove 4 screws. : PH,+,WWP,M3,L8,NI PLT ⑥ Remove the SMPS DC/DC Board. <p>⚠ : Wear gloves when handling the power board as there may be some remaining electrical charge in the capacitor. Specifically, avoid touching any part of the capacitor.</p>	

12-1-12 Separation of ASSY PDP MODULE P-LOGIC MAIN BOARD

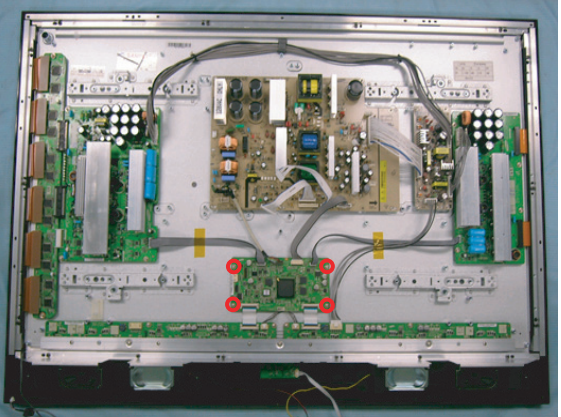
Part Name	Description	Description Photo
Logic Board	<ol style="list-style-type: none"> ① Detach all connectors from the Logic Main Board. ② Remove 4 screws. : WSP,PH,+,M3,L8,NI PLT ③ Remove the Logic Main Board. 	

12-1-13 Separation of ASSY PDP MODULE P-X MAIN BOARD

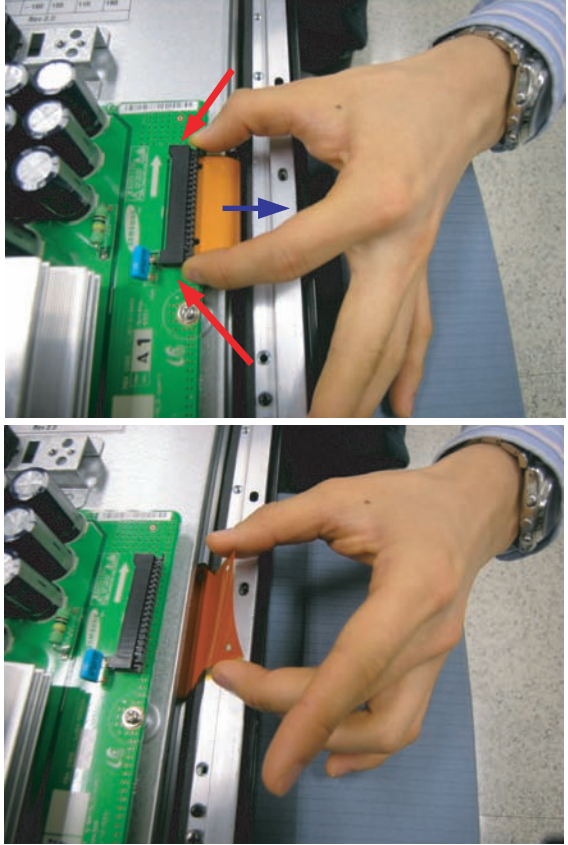
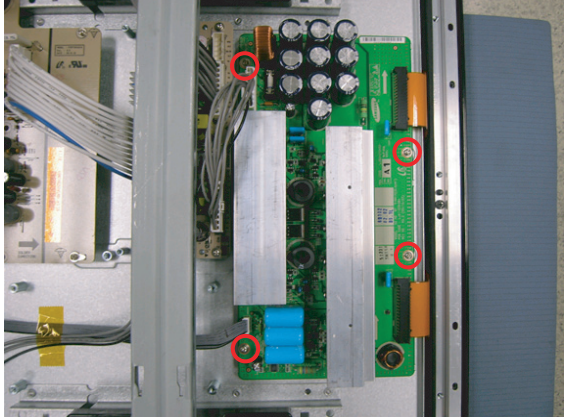
Part Name	Description	Description Photo
Flat Cable	<p>① Detach all Connectors from the X Main Board.</p> <p>※ To separate the Flat Cable of the X-Board, press the upper and the lower sides of the connector.</p>	
X-Main Board	<p>① Remove 4 screws. : PH,+,WWP,M3,L8,NI PLT</p> <p>② Remove the X-Main Board.</p>	

12-1-14 Separation of ASSY PDP MODULE P-Y MAIN BOARD

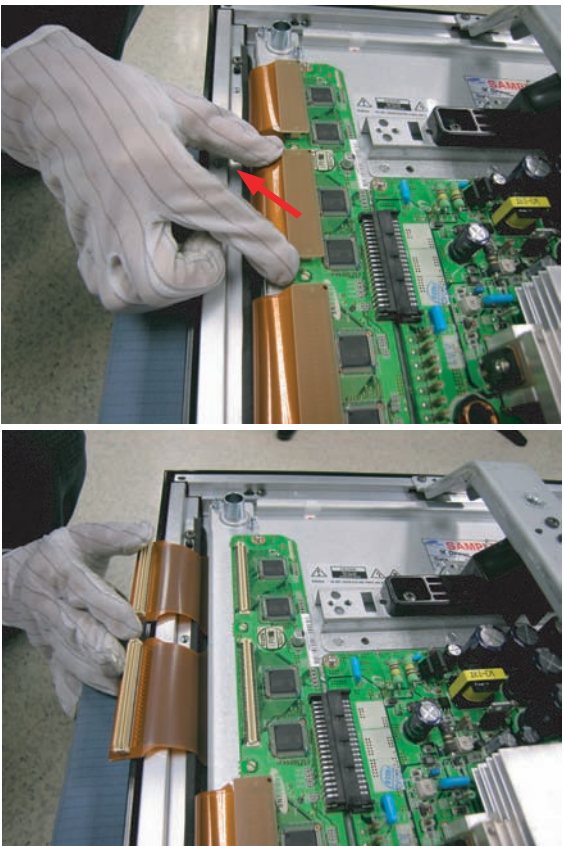
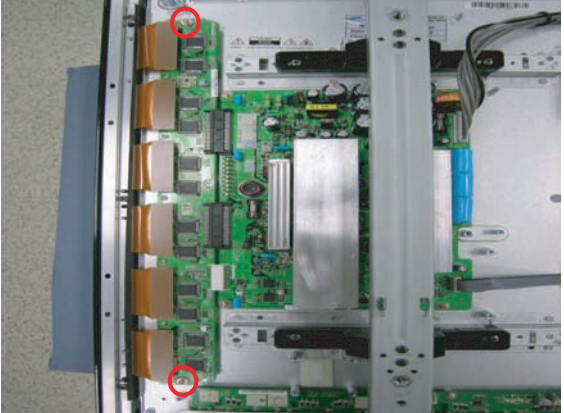
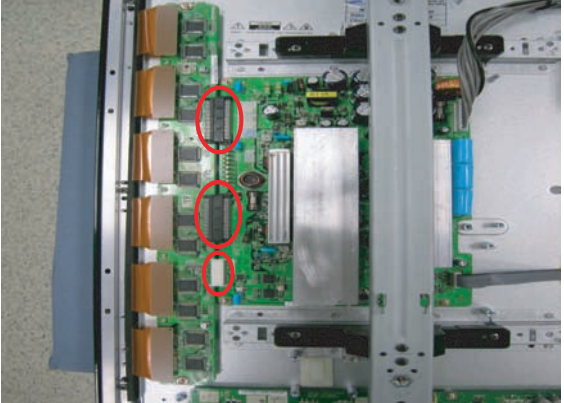
Part Name	Description	Description Photo
Flat Cable	① Detach the 6 scan board connectors from the panel by pulling the holder from both the top and bottom ends.	
Y-Scan Board	① Remove 2 screws. : PH,+,WWP,M3,L8,NI PLT	
Connectors	① Separate the scan board from the Y-Main Board by detaching the 3 connectors and remove the Scan Boards.	

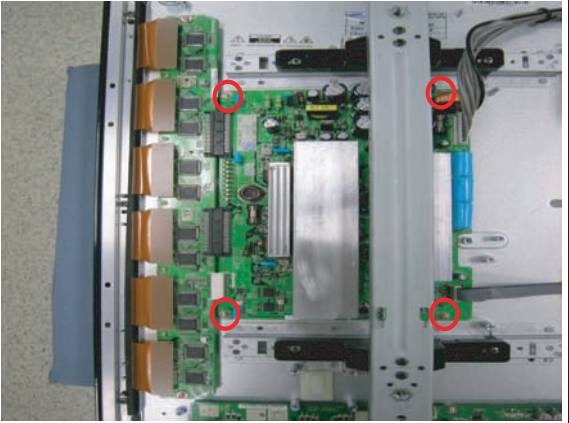
Part Name	Description	Description Photo
Y-Main Board	<p>① Remove 4 screws. : PH,+,WWP,M3,L8,NI PLT</p> <p>② Detach all connectors from the Y-Main Board.</p>	

12-1-15 Separation of ASSY PDP MODULE P-ADDRESS BUFFER BOARD

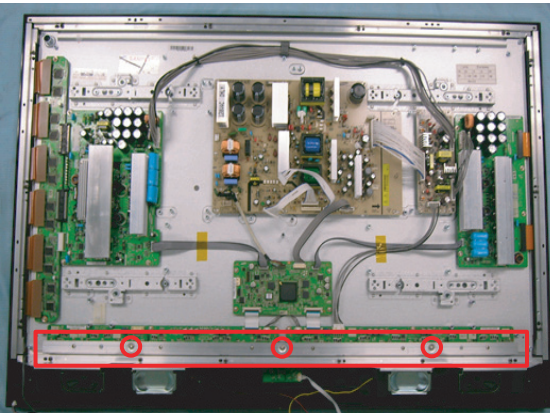
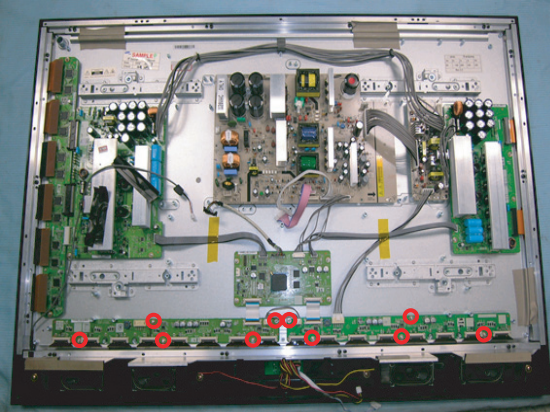
Part Name	Description	Description Photo
Still Bar	<ol style="list-style-type: none"> ① Remove 3 screws. : PH,+,WWP,M3,L8,NI PLT ② Remove the still bar. 	
Buffer Board	<ol style="list-style-type: none"> ① Detach the all connectors from the buffer board. ② Remove 10 screws. : PH,+,WWP,M3,L8,NI PLT ③ Remove the E-Board and F-Board. 	

MEMO

13. Circuit Description

13-1 Power ON/OFF Signal Timing Sequence

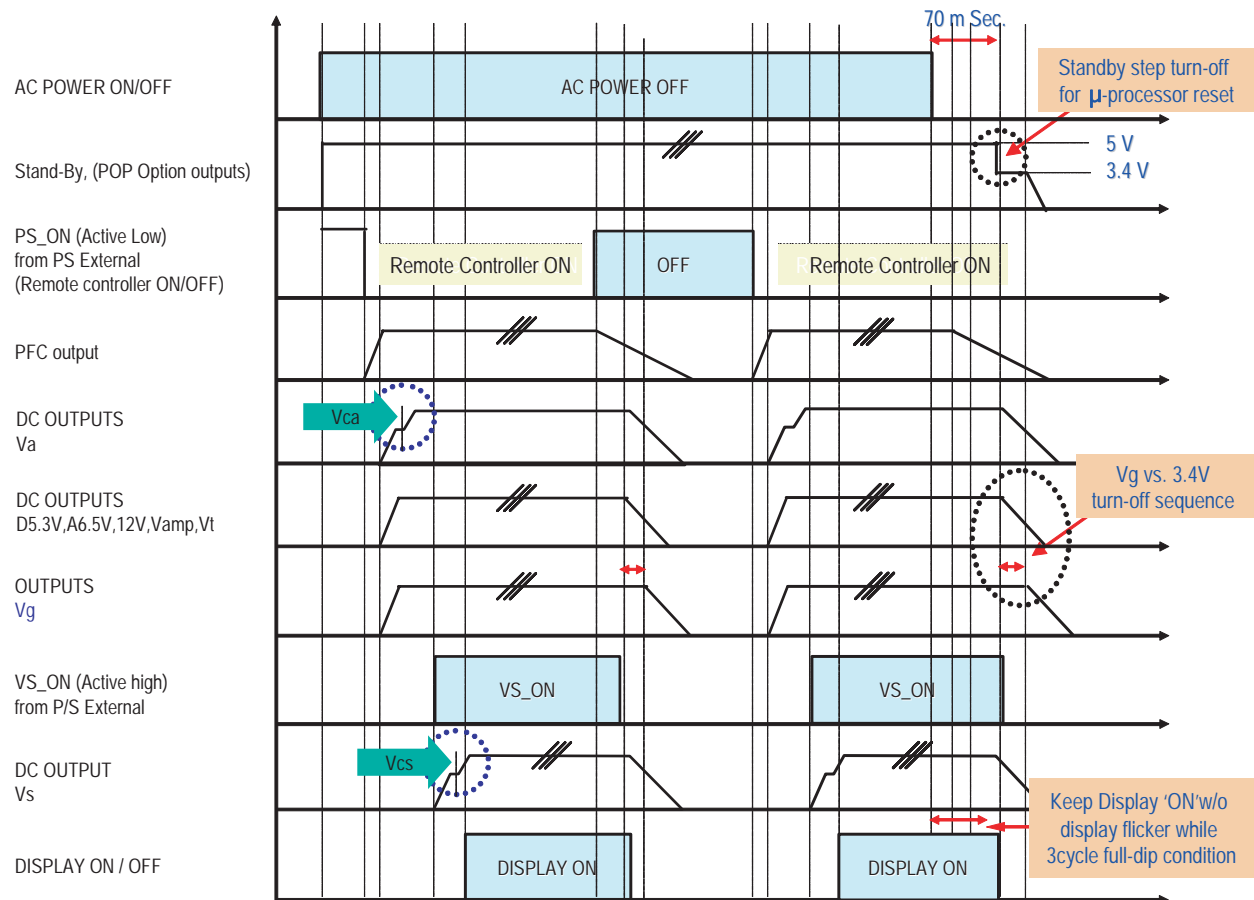

1. When connecting the AC power cord, Stand-By 5V from the Main SMPS is supplied to the Main Board (Pin 3 of CN1002 of Main Board).
2. When pressing the Power button on the remote control or on the main body, PS_ON (Pin 5 of CN1002 of Main Board) changes from High to Low.
3. If the PS_ON signal changes to Low, the Main SMPS supplies power to the Main Board and Logic Board, and Va and Vg power is supplied to the DC-DC SMPS.
4. If the VS_ON signal from the Logic Board changes from Low to High, the Main SMPS supplies VS power to the X and Y Main Board through the DC-DC SMPS, and the screen displays a picture on it.

13-2 Partial Block Description

13-2-1 Main SMPS

1. Summary

This is a service manual about the explanation of basic operation in power circuit (1H309W) for 50" PDP.

2. Input Part

This switching mode power supply (SMPS) has the input voltage range of 90 ~ 264[Vac].

Thus, at 90[Vac] input condition or any voltage level in a spec, the power board must operate even if the ac source is cut off and re-input ON.

3. Output Part

This power circuit has the 10 outputs. In steady state, the specification about the output's voltage and current is the same as following Table 1.

Table 1. PDP SMPS's output specifications (for 50")

Output Circuit	Nominal Voltage [V]	Voltage Adjustment [V]	Total Regulation	Nominal Load [A]	Load Variation [A]	Peak Current [A]	Ripple Noise [mV p-p]
Vs	210	190 - 220	± 2%	1.7	0.1 - 2.5	10.0	800
Va	70	60 - 80	± 2%	0.7	0.1 - 3.0	4.5	500
D5.3V	5.3	-----	± 5%	3.5	0.1 - 5.0	6.0	50
A6.5V	6.5	-----	± 5%	1.5	0.01 - 3.0	4.0	50
FAN_8V	8	-----	± 5%	-	0.01 - 0.2	0.5	120
Vg	15	-----	± 5%	0.5	0.01 - 1.0	1.5	120
12V	12	-----	± 5%	1.3	0.01 - 1.5	3.0	120
Vamp	18	-----	± 10%	0.1	0.01 - 2.5	3.0	180
Vt	33	-----	± 5%	5m	1m - 6m	7m	300
STBY	5.0	-----	± 5%	0.5	0.01 - 1.0	1.5	50

① Over Voltage Protection

This power circuit has the function of over voltage protection (O.V.P) in all outputs.

In condition of any over voltage in each output ports, the power supply is shut-down by O.V.P function for the protection of part's damage.

② Short / Over Current Protection

Because any output ports have small impedance (smaller than 300m ohm) at the output short condition, power circuit was designed to have the function of short / over current protection (O.C.P) in all outputs. Thus, in condition of any over current in each output ports, the power supply is shut-down by O.C.P function for the protection of part's damage. The specification about the O.C.P in each port is the same as following Table 2.

Table 2. OCP specification

Protection	Output Circuit	Trip point	Notes
Over Current	Vs	3.0 - 6.0A	Shut down by Under Voltage
	Va	3.5A or more	Short Circuit Protection
	Output except Vs&Va	-----	Shut down by Under Voltage

4. Basic Function

- ① Remote Control
This power circuit has the function of remote control by using the relay (250V, 10A)
- ② Free Voltage
This power circuit has the free voltage input range.
- ③ Power Factor Correction
This power circuit has the PFC for high power factor (higher than 0.9)
- ④ Protection
This power circuit has the function of short / O.V.P / O.C.P for the protection of part's damage.

5. Explanation of Circuit Blocks

- ① Filter Circuit
Line filter consists of Common Mode Reactor L8102; L8103, Normal Mode Reactor L8101, X-condenser C8101 · C8106, Line by-pass condenser(Y-con) C8104 · C8105 and surge protection parts ; NR8101 · NR8102 · NR8103 · NR8104 · SQ8104 · SQ8105.
This block reduces the high frequency ground noise from the original ac power source.
- ② Rectifier / DC link Circuit
This rectifier circuit creates the dc regulated voltage from AC input line.
【Power Source】
 - **Sub-power Source**
The half-wave AC voltage through the D8151 creates the sub-dc source in C8121.
 - **Main-power Source**
The full-wave AC voltage through the RC8101 creates the main-dc source for PFC input.
- ③ Inrush Current Protection Circuit
In a transient response interval of the AC source injection, the high inrush current flows from ac source to this power board because of an input capacitor having the low impedance. At that interval, the part's damage is quite within the realms of possibility. The inrush current protection circuit removes this possibility in a transient interval by adding thermistor (TH8101, TH8102). After PFC input capacitor is fully charged, (in steady state), the relays (RL8101, RL8102) are ON and input normal current flows through them without any overheat.
- ④ Sub-Power Circuit
【Basic Operation】
This Stand-by block is controlled by SMPS operation ; On/off switching FET inside of PRC [pulse ratio controlled] IC (STR-V152).
Using the switching operation, we can get the energy in an input capacitor [C8121] to transmit to output-port for STD 5V, dc source for Micom and PFC controller. The PRC controller STR-V152 can be operated by injection of the Start-up current to 8 pin of it. Output voltage is also controlled by following method ;
Controlled op-amp [Z8171] keeps the output voltage to be constant in steady state by compensating an error voltage between the dividing-resistors (R8174, RX8172 and R8175) and its reference 2.5V. And then output small signal voltage of op-amp induces a Photocoupler current level on the feedback line. Dc source voltage for PFC controller comes from secondary side link in a main transformer (3-5 pin).
【Protection Function】
 - **Over Voltage Protection**
When the Vcc voltage is higher than O.V.P level [Vcc(OVP)=31.2V(TYP)], Latch is on and power board is shut down. After Latch is on, this power board can not operate before the voltage of an electric capacitor C8123 is fully discharged for about 5 minutes.
 - **Over Current Protection**
O.C.P function in STR-V152 can be obtained by sensing the MOS-FET's drain peak current per 1 pulse (Pulse by Pulse method). This sensing value comes from the voltage across sensing-resistor(R8122) between OCP(FET source,3Pin) and GND(5Pin). Thus, this power board can protect any part's damage caused by over current flowing.
 - **Over Load Protection**
If there is an overload state in output ports due to some reason, this power board operates in UVLO mode for protection of IC's damage.

• **Over Heat Protection**

If the temperature on the chip parts is higher than about 135℃, this power board operates in thermal protection mode and makes Latch on, finally this power board is shut down.

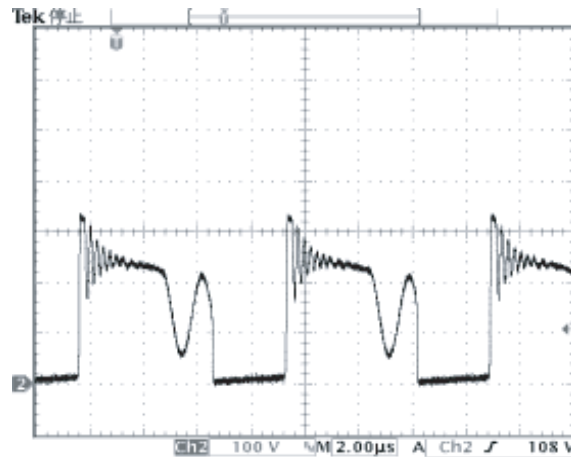

< Vds Voltage Waveform on Sub-power Circuit FET >

⑤ PFC Circuit

【Basic Operation】

After the sub-dc voltage source is on, Vcc of PFC controller IC(UCC2818A) induces the PSON port to be "L" level and this makes the oscillation with a frequency $\frac{0.6}{RT \times CT}$ (RT:R8239, CT:C8235) in it. The PFC block consists of two inside feedback

loop to control FET duty ratio. The first is the voltage loop that keeps the output voltage to be constant by sensing the output voltage in 11 pin. And the second loop controls the power factor by comparing the input line voltage (6pin) and reference in it. By this current loop, the input current waveform can be sinusoidal and now we can get the higher power factor (almost 1.0) in this power board.

【Protection Function】

• **Over Voltage Protection**

Because the PFC controller IC(UCC2818A) has the function of over voltage protection about the high output voltage limit, even if the overshoot and not-controlled state occur with the deep condition in ac input source or output step load, this controller protects the abnormal output voltage state by decreasing the FET ON ratio. The high output limit level is set to 110% value of voltage across the dividing resistors ; R8247, R8248, R8249, R8250, R8251 (this power board has also the high limit O.V.P level about 440V)

• **Over Current Protection**

PFC controller has the function of over current protection by sensing the voltage (2 pin) coming from the current-sensing resistor R8201. If the over current flows across the sensing resistor, controller decreases the FET duty ratio for protection of part's damage.

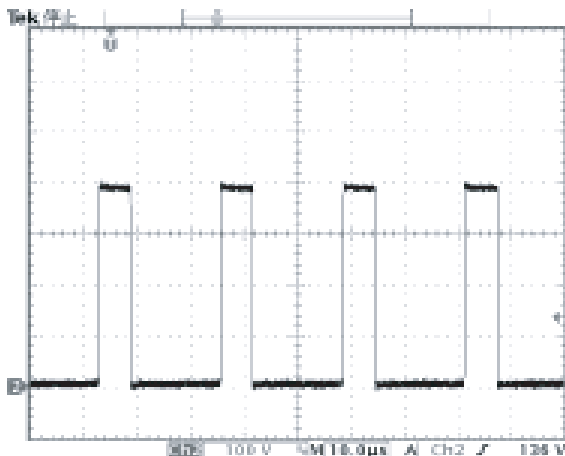

< FET Vds Waveform (100Vac input) >

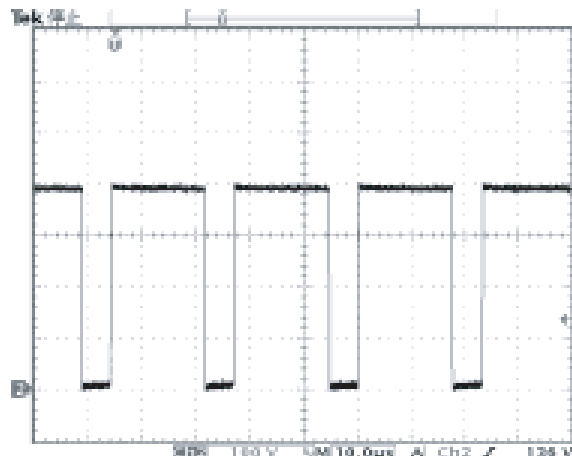

< FET Vds Waveform (230Vac input) >

6. Component Spec

Z8231	UCC2818A	18V, 20mA	TEXAS	PFC IC
Q8201, Q8202, Q8205	2SK3911	600V, 20A	TOSHIBA	PFC Switching FET
D8203	FMC-26UA	1200V, 3A	SANKEN	PFC Diode
D8205	FMX-G16S	600V, 5A	SANKEN	PFC Diode
Z8121	STR-V152	17.5V, 4A	SANKEN	ST-BY Switching IC
D8171	FMB-G14L	40V, 5A	SANKEN	ST-BY Diode
Q8301, Q8302	2SK2698	500V, 15A	TOSHIBA	Half SMZ FET
Q8502, Q8503	2SK2698	500V, 15A	TOSHIBA	SMZ FET
Z8333	SI-3150C	35V, 1.5A	SANKEN	Regulator
Z8334	SI-3050J	25V, 2.0A	SANKEN	Regulator
RC8336	FMX-22S	200V, 10A	SANKEN	Vamp Output Diode
D8332	1SS244	250V, 625mA	ROHM	Vt Output Diode
RC8331	FMX-22S	200V, 10A	SANKEN	Vg Output Diode
RC8332	FMB-26L	60V, 10A	SANKEN	12V Output Diode
Q8332	2SK2232	60V, 25A	TOSHIBA	6.5V Switching IC
RC8333, RC8334	FMB-26L	60V, 10A	SANKEN	6.5V Output Diode
Q8331	2SK3659	20V, 65A	NEC	5.3V Switching IC
RC8335	FME-24H	40V, 15A	SANKEN	5.3V Output Diode
Q8401	2SK2698	500V, 15A	TOSHIBA	Va FET
RC8401	FMX-G26S	600V, 10A	SANKEN	Va Output Diode
RC8551	FMG-26S	600V, 6A	SANKEN	Vs Output Diode
RC8101	RBV-1506J	600V, 15A	SANKEN	Bridge Diode
RL8101, RL8102	G5PA-1-M-E	250V, 10A	OMRON	Relay

13-2-2 PDP Module

1. Logic Board

■ A name of main part of Logic Board and vocabulary.

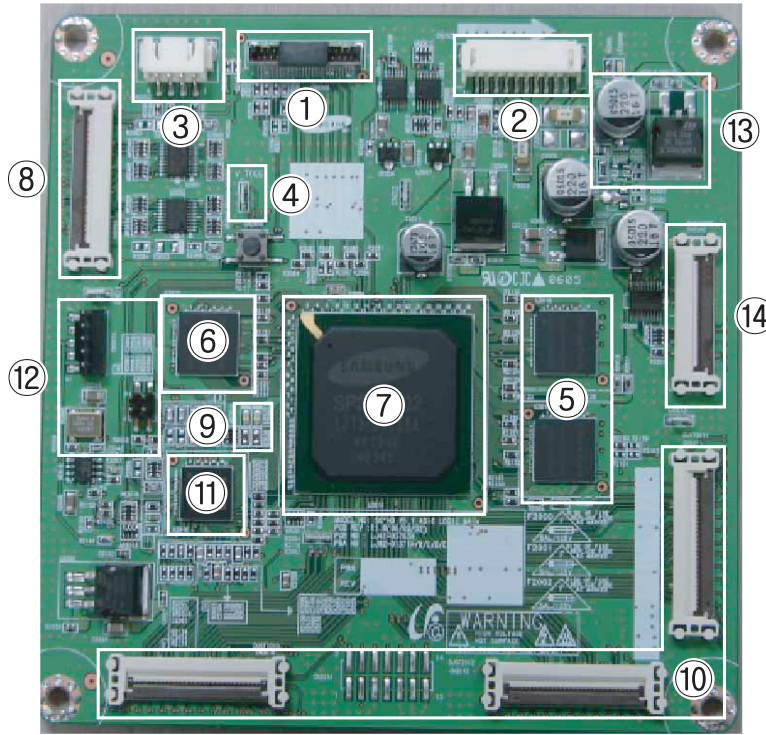

Item	Name	Explanation												
①	LVDS Connector	The connector to receive the RGB, H, V, DATAEN and DCLK signals that have been LVDS encoded through the video board.												
②	Power Connector	The connector receiving the power (5V) and control signal with the logic board.												
③	Communications Connector	The connector connecting the Keyscan which controls the pattern and registry value and the Window Manager and the page board for 512K loading.												
④	V-TOGG	V-SYNC output pin.												
⑤	DDR MEMORY (MENCON)	The Memory to restore Address output data.												
⑥	DDR MEMORY (SFP)	The memory for the drive output and frame delay data storage.												
⑦	ASIC CHIP	The main processor that generates and outputs the logic drive signal and the address data.												
⑧	Y Connector	The connector to output the control signal for the Y drive board.												
⑨	Operating Status LED	The LED that shows whether the Sync and Clock signal is properly supplied to the logic board. (Normal Status: Blinks at 0.5 second intervals) LED2001 Lights up for 2 seconds at the initial operation, and LED2002 flickers at an interval of 0.5 seconds.												
⑩	CN2010, CN2011, CN2012	The connector to output the address data and the control signal to the E, F, G-buffer board.												
⑪	ARM-PROCESSOR	IC block Control-signal to drive logic main.												
⑫	Micom Loading 5Pin Connector Initial image option PIN	The connector to load the Micom drive program. (CN2015) The program is loaded by connecting to the GA-WRITER. Initial image select F/W or BLACK : Jumper Yes : <table border="1" style="display: inline-table; vertical-align: middle;"><tr><td>4</td><td>3</td></tr><tr><td>2</td><td>1</td></tr></table> or <table border="1" style="display: inline-table; vertical-align: middle;"><tr><td>4</td><td>3</td></tr><tr><td>2</td><td>1</td></tr></table> Full White, Jumper No : <table border="1" style="display: inline-table; vertical-align: middle;"><tr><td>4</td><td>3</td></tr><tr><td>2</td><td>1</td></tr></table> Black	4	3	2	1	4	3	2	1	4	3	2	1
4	3													
2	1													
4	3													
2	1													
4	3													
2	1													
⑬	Main Power Input	The power port receiving 5 V from SMPS and output 3.3 V. (L4957AD3.3V regulator applied)												
⑭	X Connector	The connector to output the control signal for the X drive board.												

■ About Logic Board

The Logic Board consists of a Logic Main board, which processes the video signal input through LVDS and creates the address driver output and XY drive signals, and a Buffer board, which buffers the output signal and outputs the signal to the Address Driver IC (TCP IC).

Logic Board		Function	Remark
Logic Main		<ul style="list-style-type: none"> - Video Signal Processing (W/L, error diffusion, APC, FCR) Built-in LVDS Application and 1 ASIC Chip - Outputs the Address Driver Control and Data Signals to the Buffer board - Outputs the XY Drive Board Control Signal - Major Drive Voltage Monitoring (MICOM Circuit Block) <ul style="list-style-type: none"> : Detects abnormal voltage applications and protects drive circuits - Temperature Induced Operating Mode (Low Temperature/Room Temperature/High Temperature) <ul style="list-style-type: none"> : Optimization of discharge by temperature 	
Buffer Board	E Buffer Board	Outputs data and control signals to the bottom left TCP IC.	Single Scan and RSDS applied
	F Buffer Board	Outputs data and control signals to the center up TCP IC.	
	G Buffer Board	Outputs data and control signals to the bottom right TCP IC.	

■ Normal Waveform

When the Operating LED blinks normally (at 0.5 second intervals), which indicates the normal operation of the PDP Set and Logic Board, and the V-SYNC and data output signals are normal.

If the set is out of order, perform troubleshooting according to the procedures below.

- 1) Visual Inspection : Check if the Operating LED on the Logic Main blinks at a 0.5 second interval.
 - ▶ If the Operating LED blinks too fast or too slow, you have to reload the data onto the MICOM, as this indicates abnormal data processing in the MICOM. To load the data, supply power to the module and load the data using GA-WRITER.
- 2) If no problem has been found through the visual inspection, check if the drive waveforms and the address data output are normal. (Check Point: Check the DAMPING R-NET output of each data output terminal.)
 - ▶ If no drive waveform or address output signal is detected, load data onto the MICOM according to the procedures described above, as this indicates a MICOM data error.
 - ▶ If data output is detected but is abnormal, it indicates a hardware short-circuit if measured for the drive waveform, or it indicates abnormal data output due to the abnormal operation of the DDR memory caused by the abnormal Vref voltage if measured in the address data. Abnormal data output due to the abnormal operation of the DDR memory or a short circuit on the board, which may be caused during the ass'y process, causes the screen to be abnormally displayed. Therefore, you have to conduct a short test for each part.
 - ▶ If the Vref voltage (Voltage Divider Voltage) is lower than 1.25V, check the resistance of the resistance output part and check if the circuit status is normal. This applies the voltage and the proper Vref voltage and results in the screen being properly displayed.
 - ▶ If the screen is abnormally displayed, even though the Vref voltage is normal, find any abnormal points by conducting a short test. If a short circuit is found and it is repairable, repair it. If a short circuit is internal, replace the board.
 - ▶ The following waveform appears when the V-sync and address data are output properly.

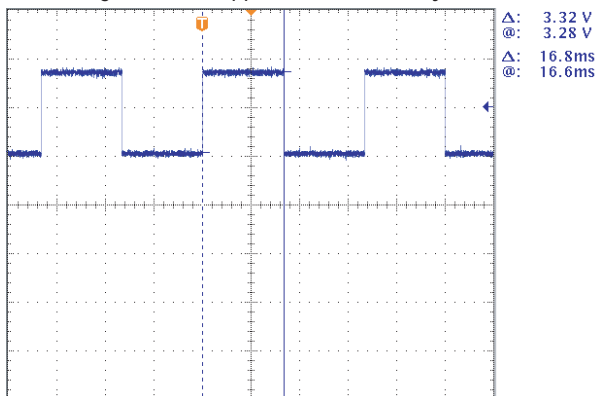

< Normal V-SYNC Output Waveform >

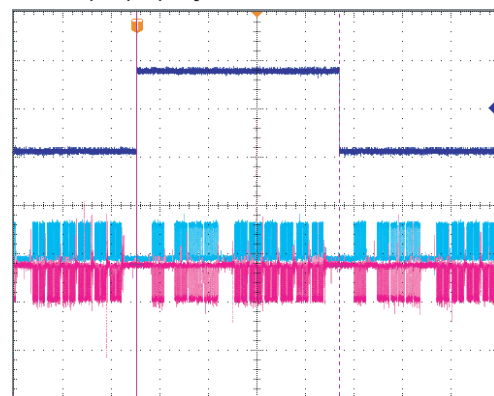

< Normal Address Data Output Waveform >

2. X, Y Control Block

■ Drive Circuit Definition

The Drive Circuit is a circuit that generates a waveform (high-voltage pulse) for the X and Y electrode group of the panel's external port so as to control the panel. The high-voltage switching pulse is generated through the combination of the IC HYBRID (Drive block + IGBT) and FET.

■ Drive Circuit Mechanism

A picture is displayed on the PDP by applying voltage to the X, Y and ADDRESS electrodes of each pixel according to the appropriate condition. The drive waveform applied to 42HD V4 is of the ISSS (ISSS: Interweaving Scan and Selective Sustain with Scan IC) type and has IDS (InDependent Sustain) in the Scan section unlike the existing ADS. Discharges within a PDP pixel can be classified into 3 types:

- ① Address Discharge: To form a wall voltage within the pixel by giving information (applying DATA voltage) to the pixel to be lit.
- ② Sustain Discharge: Sustain Discharge is a display section that voluntarily maintains the discharge of the pixels whose wall voltage has been formed by the Address Discharge. (Optical output for displaying a picture is generated).
- ③ Erase Discharge: To selectively perform Address Discharge for each pixel, all pixels on the panel should be in the same status (the wall electric charge status and space electric charge status must be the same). Therefore, the Erase Discharge section is an important component for guaranteeing the drive margin, and is implemented by various methods such as applying a log waveform. However, the current 42HD V4 has adopted a wall voltage control through an RA (Repeated Auto-quenching) reset that separates the discharge area and performs switching to perform an efficient erase operation, while the gradient was the same in the RAMP section in the existing approach.

1) Address Discharge

A discharge that is caused by the difference between the plus electric potential (V_a apply voltage of 65~70V + Positive Wall Charge) of the electrode and the negative electric potential (Applied GND Level + Negative Wall Charge) of the Y electrode. The Address discharge forms a wall voltage within the pixel to display color (to be discharged) before the Sustain Discharge period. That is, the pixel whose wall charge has been formed by the Address Discharge forms a Sustain Discharge via the following Sustain pulse.

2) Sustain Discharge

A Sustain Discharge is a Self-Sustaining Discharge formed by the accumulation of the electric potential of the Sustain pulse (generally 200 ~ 210 Volt) alternating over the X and Y electrodes during the sustain period, and the wall charge depending on whether the pixel has previously been discharged or not. That is, it is controlled by the memory characteristics, one of the basic characteristics of the AC PDP (in that the past operating conditions determine the current status). That is, if a wall voltage exists on the pixel (if the pixel is on), a discharge is formed again because the applied voltage, which is the sum of the following applied Sustain voltage and the wall voltage, is higher than the discharge threshold voltage. If no wall voltage exists on the pixel (if the pixel is off), a discharge will not occur because the Sustain voltage is not higher than the discharge threshold voltage. The Sustain Discharge period is the period for generating actual optical output so as to display a picture on the PDP screen.

3) Erase Discharge

The purpose of a Reset (Erase) Discharge is to create uniformity of the wall voltage within all panel pixels. It evens the wall voltages regardless of the Sustain Discharge in the previous stage. The Erase Discharge has to remove the wall voltage introduced by the Sustain Discharge by supplying ions or electrons by a discharge. When the wall voltage is removed through a discharge, the time when the reverse polarity is applied to the wall voltage (fine width erasing) is to be limited or ions or electrons are to be supplied by a weak discharge (low voltage erasing) so as to prevent a wall charge in reverse polarity.

There are 2 known weak discharge (low-voltage) erase methods. 1) A log waveform adopted by F company and 2) a weak erase discharge via a ramp waveform adopted by Matsushita and other companies. Both methods control the externally applied voltage by the difference of the wall voltage of the pixel by applying the rising gradient of the erasing waveform slowly, because the discharge begins when the sum of the existing remaining wall voltage and the rising waveform voltage exceeds the drive threshold voltage. In addition, a weak discharge is introduced, because the applied voltage is low.

■ Requisite Components Necessary for Drive Board Operation

1) Power

- Supplied from the power board. The optimal value may differ from the following:
 - a) V_s : 200V - Sustain
 - b) V_{set} : 190V - Y Rising Ramp
 - c) V_e : 110V - V_e bias
 - d) V_{scan} : -190V - Scan low bias
 - e) V_{sc_h} : -70V - Scan high bias (Created by the DC-DC power block of the Y Drive board)
 - f) V_{dd} : 5V - Logic signal buffer IC
 - g) V_{cc} : 15V - Gate drive IC

2) Logic Signal

- Supplied by the Logic board
- Gate signal of each switch

■ Drive Circuit Architecture and Function Description

- Description of the function of each board

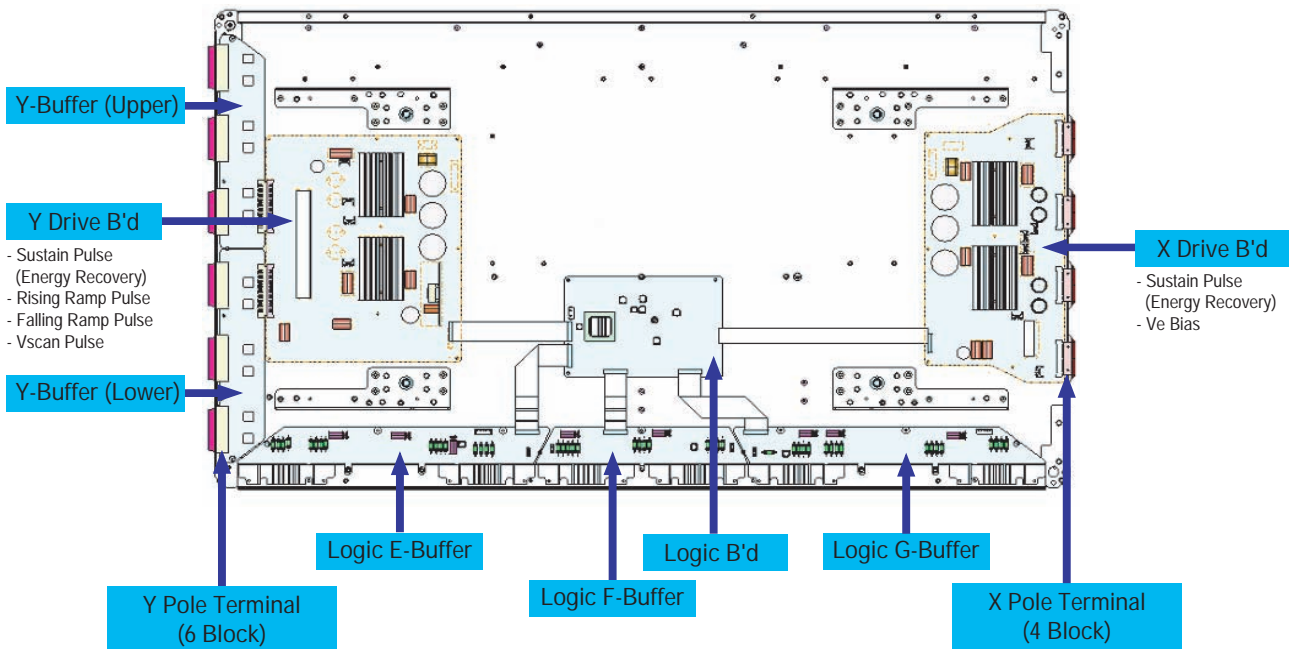

1) X Drive Board

This is connected to the X port part of the panel. 1) Sustain voltage waveform (including ERC) is output, and 2) V_e bias in the Scan section is maintained.

2) Y Drive Board

This is connected to the Y port part of the panel. It outputs 1) Sustain voltage waveform (including ERC), and 2) Y Rising, Falling Ramp waveform, and maintains 3) V_{scan} bias.

3) Y Buffer Board

A board, which applies the Scan waveform to the Y terminal block, consists of 12 Scan Driver ICs (TI SN755870: 64 Outputs).

■ Drive Waveform Specifications

- Drive Waveform

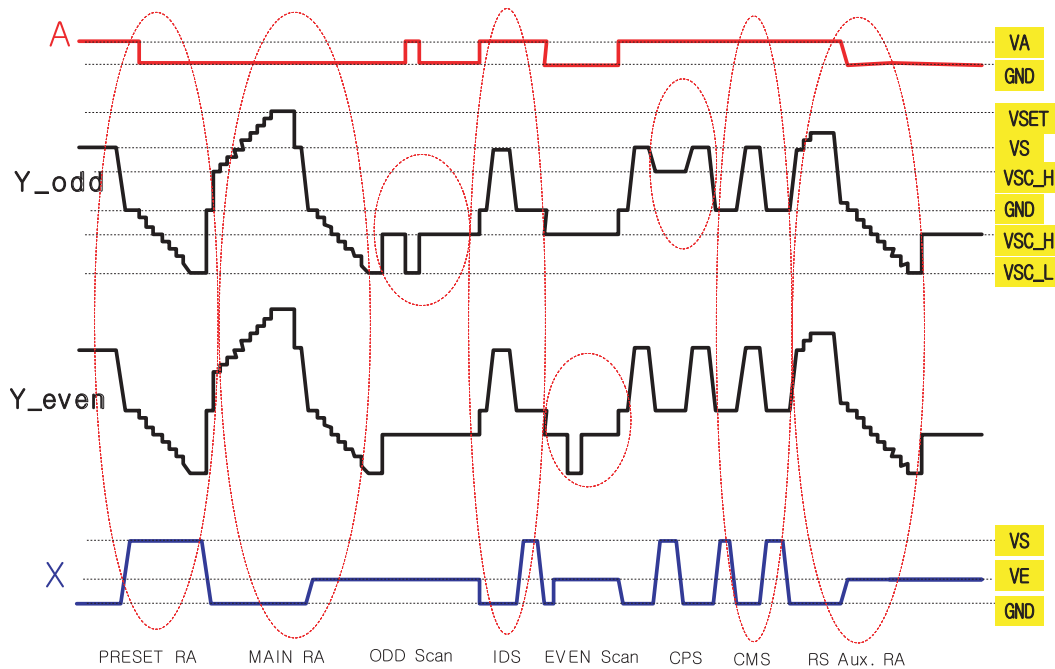

- Description of the function of each pulse

1) Y Preset RA Pulse

This is supplied to the first sub-field and erases the discharge status of the previous subfield.

2) Y Main RA Pulse

During the Y Rising Ramp section, approximately 300V~350V ($V_{scan-h} + V_{set}$) of external voltage is supplied to the Y electrode, and a weak discharge is started when each gap voltage is equal to the discharge start voltage. While maintaining the weak discharge, as a whole, negative wall charges are accumulated on the Y electrode and positive wall charges on the X electrode and the address electrode.

During the Y Falling Ramp section, the negative wall charges accumulated on the Y electrode by the approximately 105V of X bias are used to erase the positive wall charges on the X electrode, and the address electrode maintains most of the positive wall charges accumulated during the (0V) Rising Ramp section preparing for the next address discharge.

3) Y Scan Pulse (Odd/Even)

A scan pulse classifies the Y electrode into Odd and Even lines and selects FPC output electrodes sequentially (one line-at-a-time). At this time, V_{scan} is called the Scan Bias Voltage.

A V_{scan} voltage of approximately -175 Volt (V_{sc-1}) is supplied to the electrode lines. For the other lines, -56 volt (V_{sc-h} is higher than V_{sc-l} by 120V) is supplied. However, negative wall charges are accumulated on the Y electrode by the Ramp pulse, and positive wall charges are accumulated on the address electrode, and the voltage applied to the cells, to which the Address pulse (70V~75V) has been applied, becomes higher than the discharge voltage. An address Discharge occurs as a result. Since the Scan and Data pulse is applied one line at a time as above, the address time of PDP is very long.

4) IDS Pulse (InDependent Sustain Pulse)

Since an Odd Scan is performed first, the Odd line output sustains optical twice during the IDS section. At this time, a Sustain Discharge does not occur for the Even line because the Even line is not scanned.

5) CPS Pulse (ComPare Sustain Pulse)

By floating the Odd line that caused the Sustain Discharge in the IDS section to the V_{scan-h} level, and introducing the Sustain Discharge only for Even lines, it compensates for the optical output difference between the Even and Odd lines.

6) CMS Pulse (ComMon Sustain Pulse)

Actual optical is output during the common Sustain Discharge section.

■ Mechanism of the FET Operation and High-Voltage Switching

Mechanism of the FET Operation

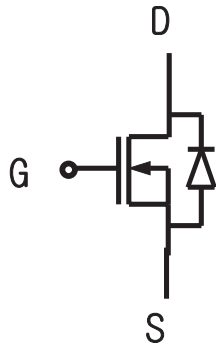

G : Gate
S : Source
D : Drain

- 1) When the signal is output to the gate, (positive electric potential) FET short circuits (i.e. Conductor of resistance 0)
- 2) When no signal is output to the gate (GND), FET changes to an open circuit (i.e. an insulator of resistance ∞).

High-Voltage Switching of the FET Operation

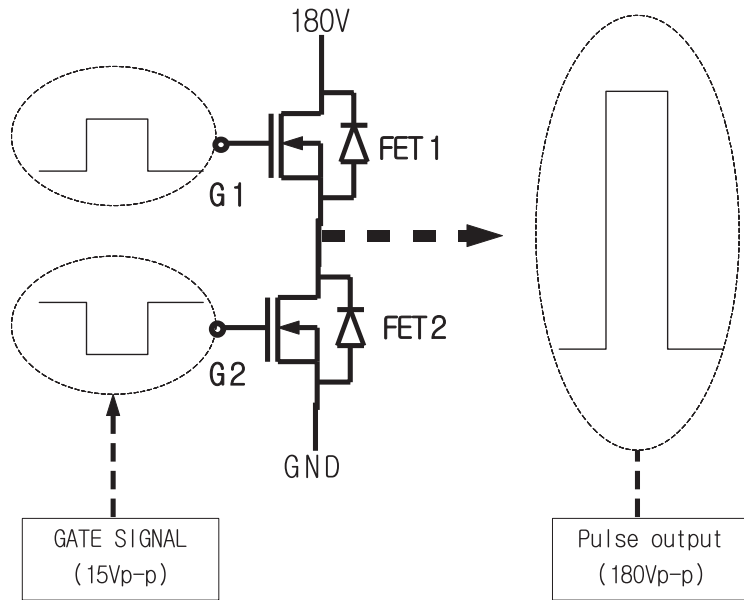

- 1) When no signal is applied to G1, FET1 is opened and when the signal is applied to G2, FET2 short circuits, GND is output via the output terminal.
- 2) When a signal is applied to G1, FET1 short circuits and when no signal is applied to G2, FET2 is opened, and 180V is output via the output terminal.

■ Drive Board Connector Layout
 1) X-Main Board

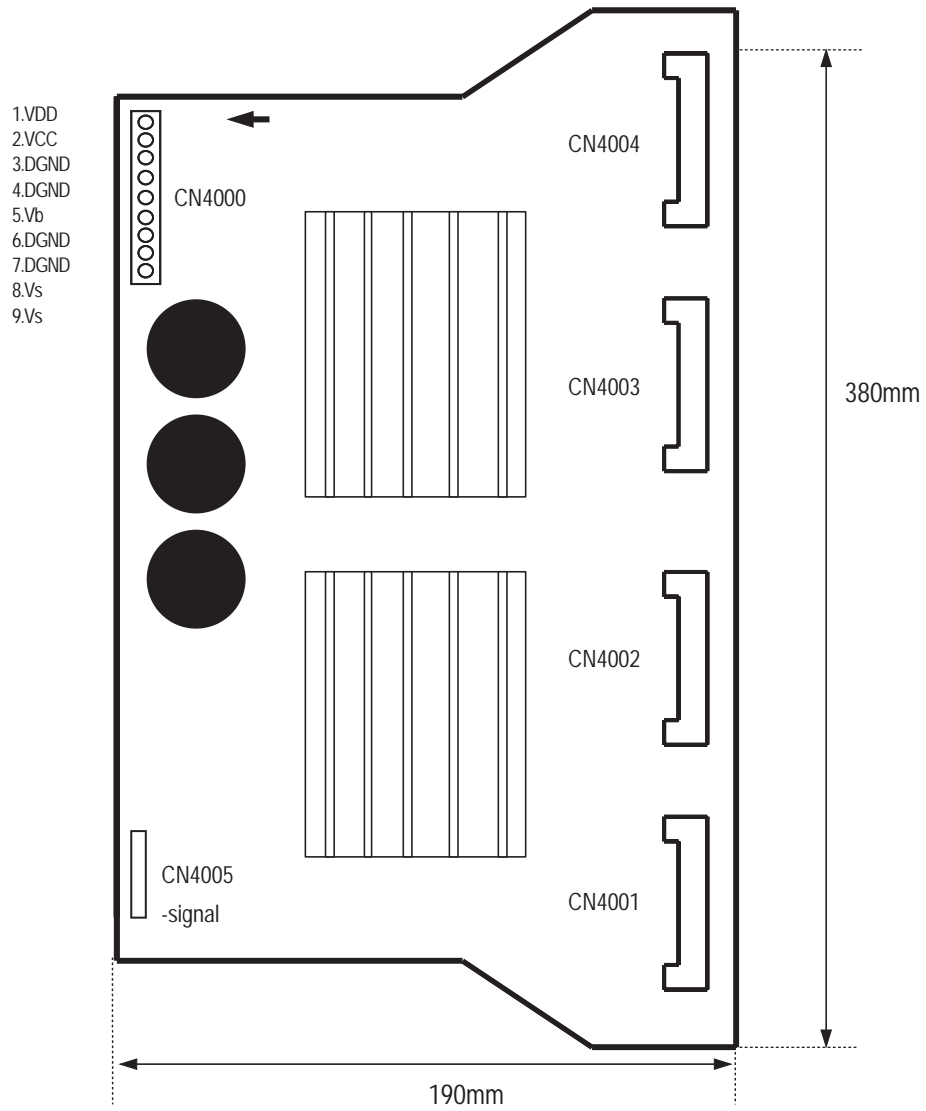

2) Y-Main Board

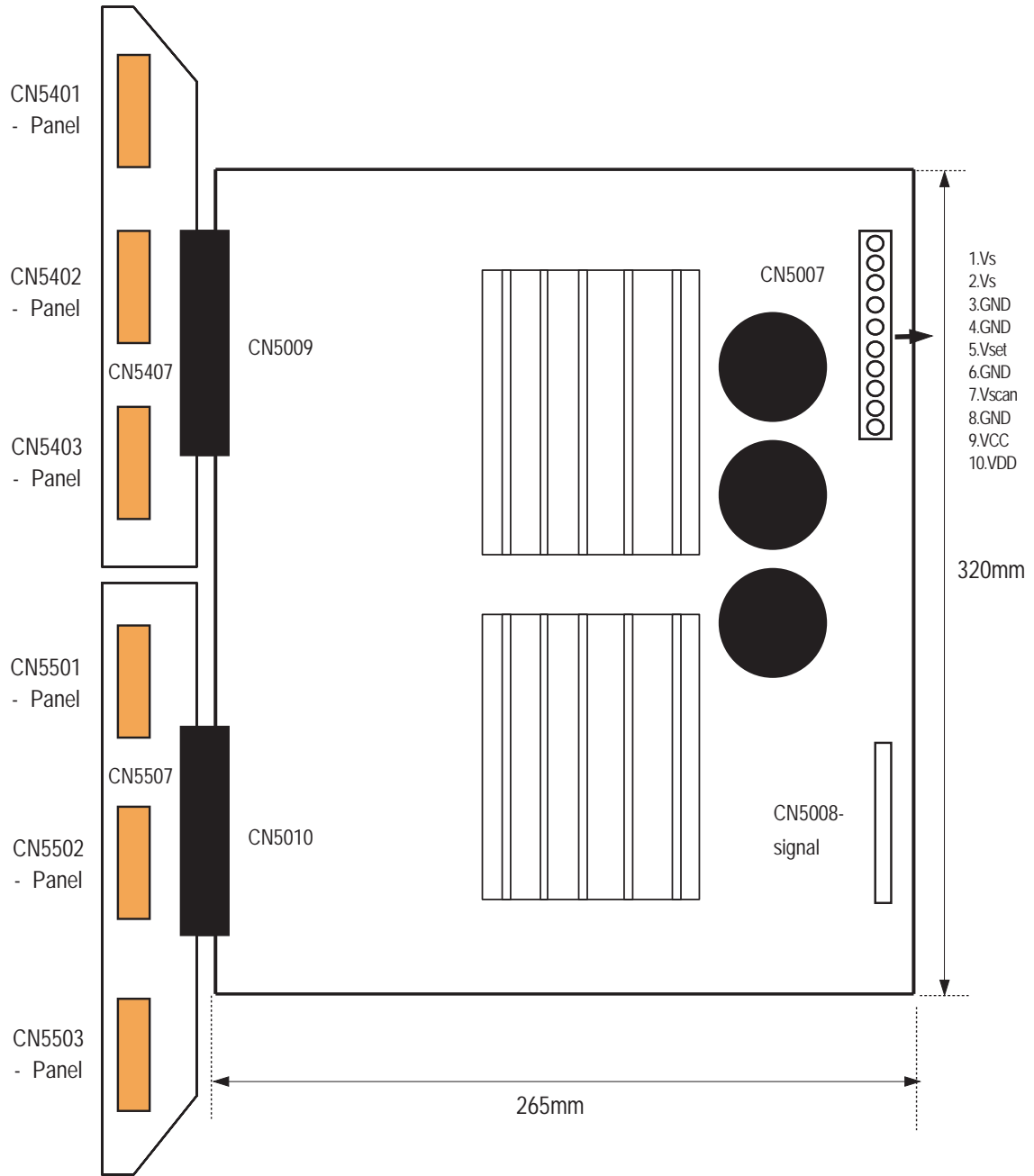

- ▶ Adjust the drive waveform so that the main reset (rising, falling:40usec) is the same as those in the F/W pattern.
(※ Attachment 1 reference)

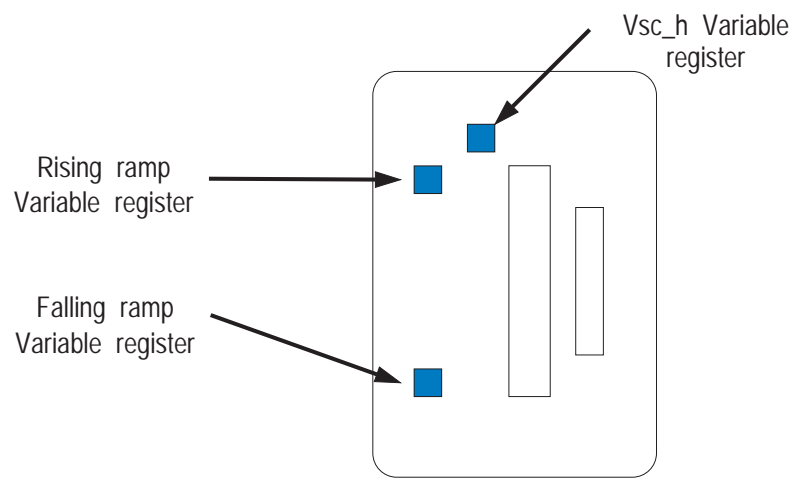
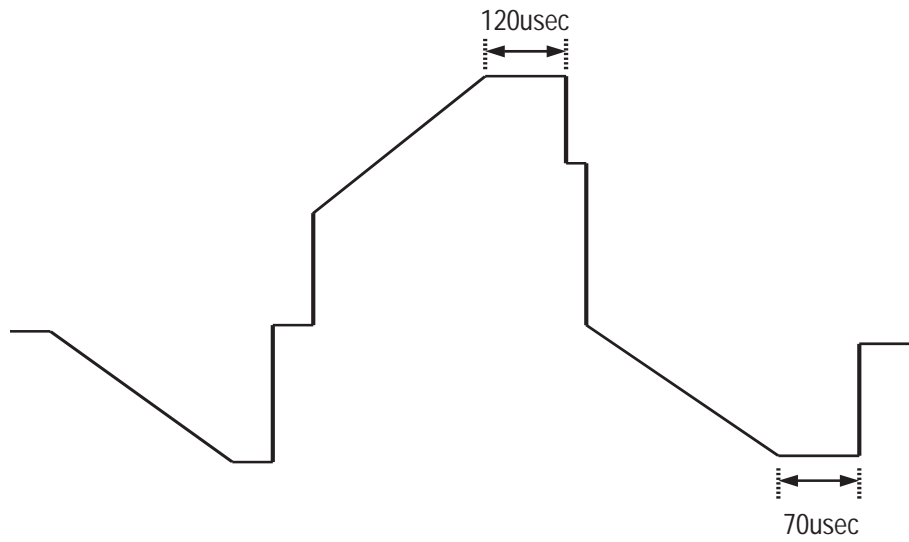

< Y-Main >

<Voltage Adjustment Specifications>

Vset	Vs	Vsc_l	Vsc_h	Ve	Va
190V	200V	-190V	-70V	115V	65V

- ▶ Check that the output of X-Out of the X board follows the waveform of ※ Attachment 2 when the power is supplied.

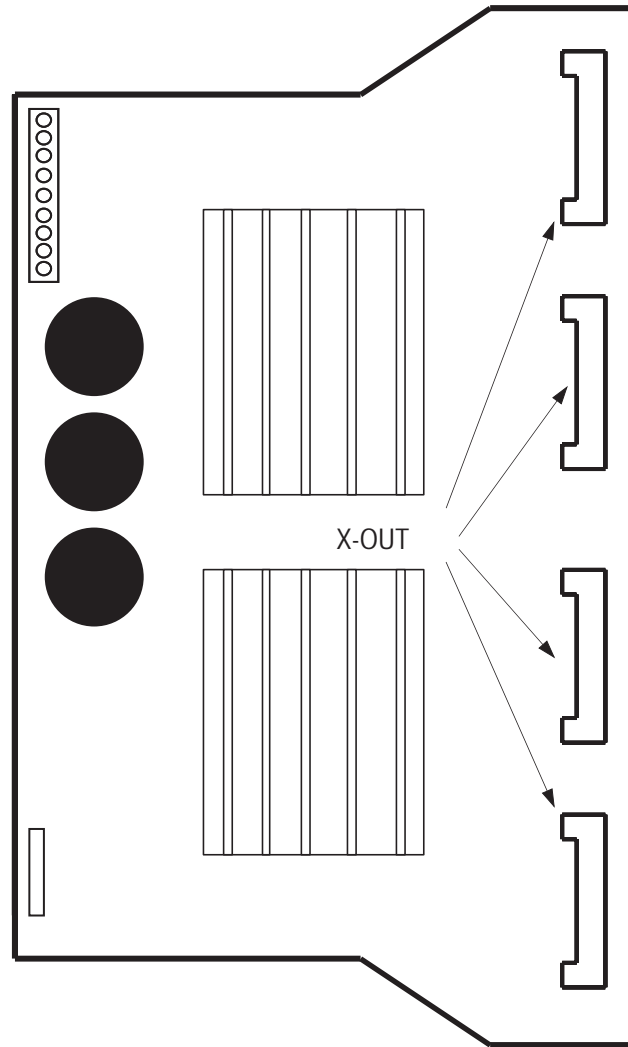

- ※ Attachment 1
- Y Output Waveform

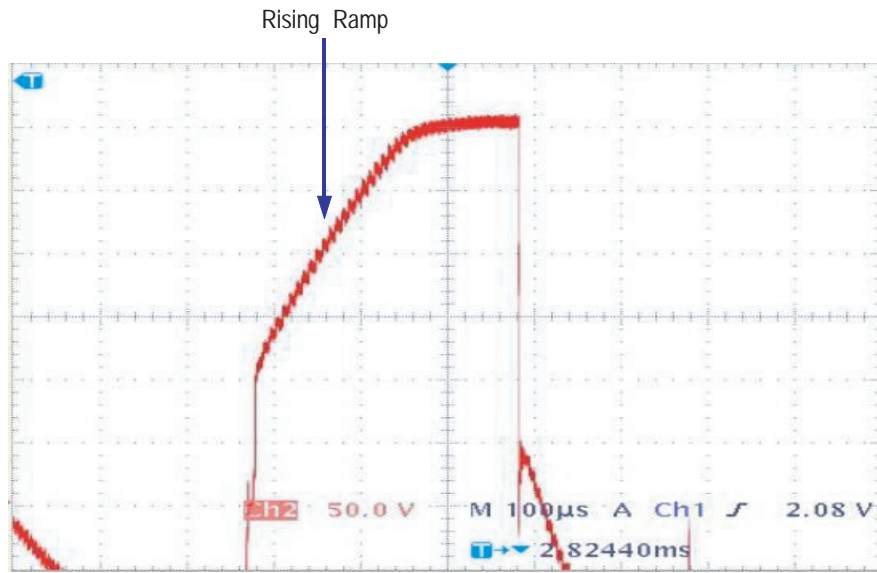

< Rising Ramp >

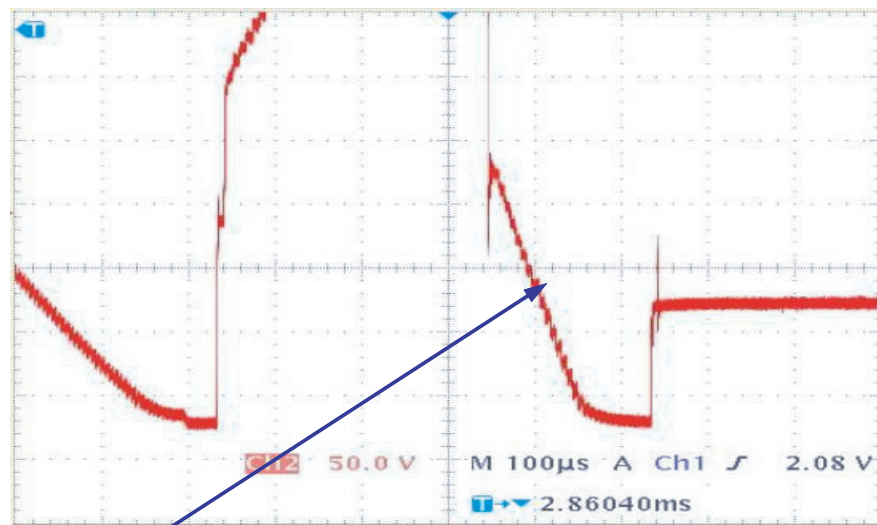

Falling Ramp

< Falling Ramp >

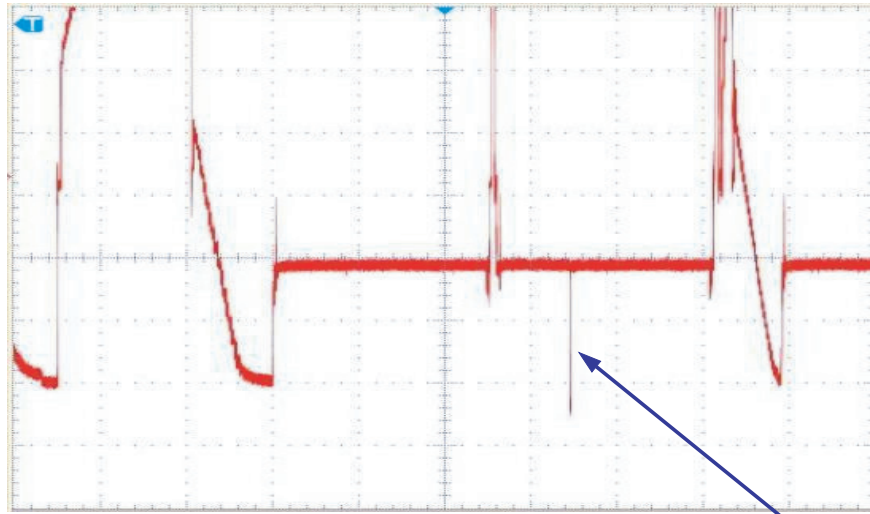

< Even_Scan >

Scan_I

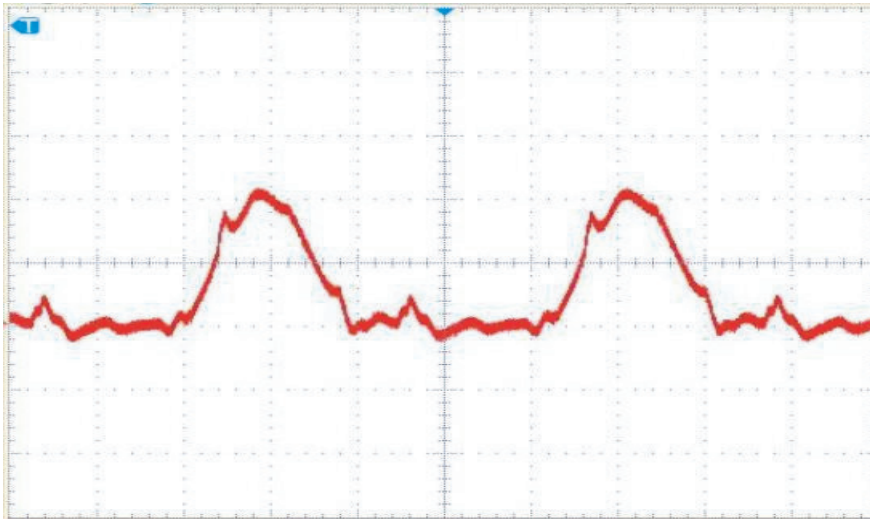

< Y Sustain >

※ Attachment 2

■ X Output Waveform

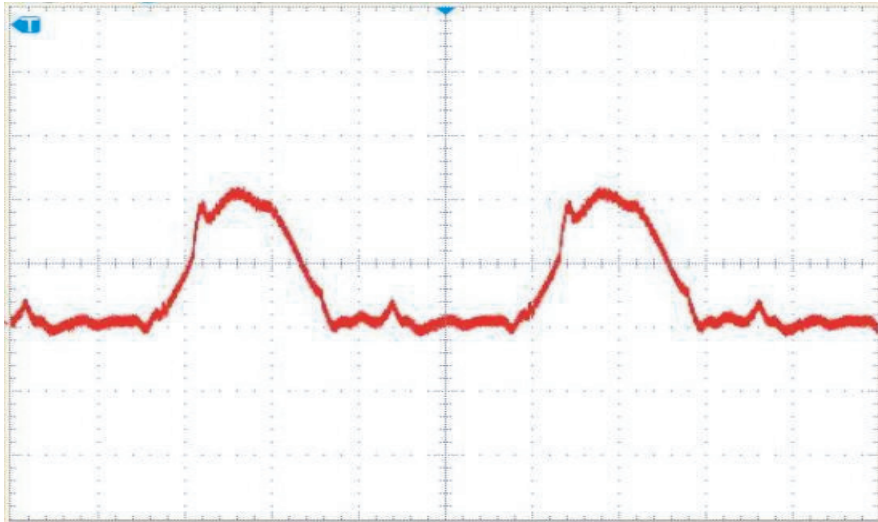

< X Sustain >

MEMO

14. Reference Information

14-1 Other issues related to other products

Problem	Descriptions
A fixed screen can cause permanent damage to the TV Braun tube.	Braun, PDP and LCD TVs can all be damaged. When a still image is displayed in a sequence, this can leave stains or after-images due to the characteristics of the panel. However, the DLP TV has the advantage that no stains or after-images are left on the screen. The DLP TV has mirror pixels on the DMD panel that project the beam onto the screen, in which the mirror is a digital representation of 0s and 1s, leaving no trace of light. The mirror returns to a blank state so that no stains or after-images are left.
Confusion between the ANYNET Port and the SERVICE Jack Port	The SAMSUNG SKY500N model has both an ANYNET port and a SERVICE jack port. Because the shape of the ANYNET port on the DLP TV is the same as that of the SERVICE jack port of the SKY500N, it fails to turn the TV off after a connection has been reported. The ANYNET port uses an RS232 port called Phone Jack, and the SERVICE jack port also uses the RS232 port. However, you must not connect the SERVICE port and the ANYNET port. Check if the port is the ANYNET port or the SERVICE port before connecting the port. Even if the TV cannot be turned on after connecting, the TV will turn on if you disconnect the connection.
Length of DVI Cable / PC RGB Cable	<ul style="list-style-type: none"> - A too long DVI cable may cause a malfunction or degradation of the visual quality due to an attenuation of the signal. There is no recommendation for the cable length at present. In general, although a cable length of up to 5 meters should work, please check if video is properly displayed on the screen after connecting. If you think the length of the cable is longer than for normal use, check the visual quality of the video on the screen and shorten the length, if necessary. - This also applies to the PC RGB (D-Sub) cable. When the length of the cable is longer than for normal use, video may not be displayed on the screen. In this case, shorten the cable length.
When a digitally distributed TV user receives HD-rated broadcasts:	The digital distributed TV (Ready Technique) can render HD sources as HD-rated. However, you need to install a set-top box for this purpose. The digital TV alone cannot render HD broadcasting as HD-rated. Install the formal set-top box for HD broadcasts.
When a digital distributed TV user selects normal size (4:3) to receive SD-rated digital broadcasts:	The digitally distributed TV (Ready Technique) renders any broadcasting service as SD-rated. However, when connected to a set-top box, the digital TV renders HD broadcasts as HD-rated and renders SD as SD-rated. The screen size is scaled to 4:3.
When a digitally built-in TV user receives SD (air) broadcasting:	The digitally integrated TV ("built-in" type) renders SD broadcasting as SD-rated. This can be understood easily. Even a high-resolution TV cannot improve a low resolution picture into high quality. In contrast, an SD-rated TV cannot represent HD broadcasting as HD because the resolution of the TV is lower than the original.
When selecting a picture size of 4:3 in connection with a computer or a multimedia device:	The representation capability of SD or HD-rated depend entirely on the TV set. The HD TV can render HD broadcasting as HD-rated only when it receives HD sources. In the meantime, the HD TV renders SD as SD-rated when it receives SD sources. The picture size has nothing to do with the resolution; TV models like SVP-XXL3HD or SVP-XXL6HD have a size adjustment feature to 16:9, 4:3, Panorama, Zoom1, Zoom2 and Auto Wide. This is about the aspect ratio of the top and bottom boundaries to the overall screen and users can select their preference.

■ SD/HD broadcasts and the TV's display capability are related

1. A digital broadcast should be transmitted in wide screen (an aspect ratio of 16:9) HD. If the broadcasting station converts a conventional program created in normal screen (aspect ratio of 4:3) into a digital signal and broadcasts the signal, the left and right of the picture will not be displayed.

This symptom also appears in other manufacturer's TV's. The three appliance companies are trying to resolve the problem through the Ministry of Information and Communication.

* When watching an SD (normal) broadcast through a Digital (Wide) TV (480P normal broadcast)

* When watching an SD (normal) broadcast through a Digital Ready (Wide) TV (Using a set-top-box)

* When watching an analog (normal) broadcast through a wide TV

(When watching a broadcast after changing the aspect ratio of the TV from 16:9 (wide screen) to 4:3)

2. When watching a DVD title or video tape in wide screen (21:9) through a wide (16:9) TV, watching video from a computer or game console by selecting the aspect ratio to 4:3, or watching video from a DVD, VCR, computer or game console through a wide TV by selecting the aspect ratio to normal (4:3) or wide (21:9), the left and right, or top and bottom of the picture will not be displayed.

This symptom appears in other manufacturer's TV's. The three appliance companies are trying to resolve the problem through the Ministry of Information and Communication.

* In TV, VIDEO, S-VIDEO, and COMPONENT(480i, 480p) modes, all screen modes can be selected.

(16:9 → Zoom1 → Zoom2 → 4:3).

* In TV(DTV), COMPONENT(720p, 1080i), PC, HDMI modes, only 16:9 & 4:3 modes can be selected.

* In Zoom1 and Zoom2 modes, you can move the picture on screen by pressing the ▲ or ▼ button.

* 16:9 : Sets the picture to 16:9 wide mode.

* Zoom1 : Magnifies the size of the picture on the screen.

* Zoom2 : Expands the Zoom1 format picture.

* 4:3 : Sets the picture to 4:3 normal mode.

■ Restrictions

1. When you want to change the picture size in PIP 'ON', you must turn the PIP off before changing the size.
However, you can change the main picture size even in PIP ON for products with no restrictions.
2. When the picture size is not Normal (4:3 for 4:3 display devices, 16:9 for 16:9 display devices) and you turn PIP on, the picture size is changed to Normal.
However, you can turn PIP on without changing the picture size for products with no restrictions.
3. The picture size can be changed even in the blue screen.
However, the picture size should be controlled by the product specifications if the change is impossible due to hardware restrictions.

14-2 Technical Terms

Virtual Channel

In digital channels, a virtual channel is used. A virtual channel is a function that enables users to watch a channel by selecting a virtual channel number regardless of the region of the user. Run Auto Channel Scan for digital broadcasts, tune in to a UHF channel number according to the region for terrestrial broadcasts, or tune into a channel number allocated by the cable broadcasting station for a cable TV network, and then select a displayed virtual channel.

For example, even if you tune into channels UHF 14(MBC), 15(KBS1), 16(SBS), 17(KBS2) and 18(EBS) broadcast from Kwanak mountain in Seoul, you can watch the channels using virtual channels such as 11-1(MBC), 9-1(KBS1), 6-1(SBS), 7-1(KBS2) and 10-1(EBS) regardless of your region and the actual local channel number. The virtual channel numbers may be used nationwide, but the virtual channel numbers may vary depending on the local broadcasting stations.

(Since the digital channel numbers may vary depending on your region and can be changed by the broadcasting policy, ask your local broadcasting station or regional cable TV network company about the channel numbers.) If the virtual channel numbers are saved and the TV set can receive digital broadcasting, you can watch a digital channel by pressing the DTV+ button and pressing the first two digits of the corresponding virtual channel number.

Custom Color Adjustment

Using this function, a user can adjust the color according to personal preferences (Red, Grass-Color, Sky-Color, Gold-Color, Skin-Color, White, Standard, Custom) without affecting other colors using automatic selection mode or fine adjustment mode.

Simultaneous Screen

Using this function, a user can view two video signals from separate video sources on a single screen at the same time. For example, you can watch TV and video simultaneously.

Dolby Digital

This is the digital sound standard developed by the Dolby Laboratory. You can select your preferred digital surround mode after connecting external speakers.

Digital Broadcasting

Digital Broadcasting is a television broadcasting signal digitized and transmitted according to the United States' terrestrial digital broadcast standard, or ATSC.

Mono

A type of audio interface that transmits the audio signal through a single channel only.

Through a mono interface, it is hard to experience stereophonic sound and the sound is played using only one speaker.

Reception Sensitivity Amplification (LNA)

A signal amplification technique that amplifies a weak broadcasting signal by applying satellite technology to provide better visual quality even for users in regions where only a weak broadcasting signal is available. (LNA: Low Noise Amplifier)

Sub Woofer

A Sub Woofer is a speaker for ultra bass sound output only whose frequency is as low as 150Hz. There are two types: an active type which includes an amplifier, and a passive type, which requires an additional amplifier.

Stereo

A type of audio interface that transmits audio signal through 2 channels.

Stereo transmits audio signals for right and left sound so that you can experience stereophonic sound, and the sound is played through 2 speakers.

Partial Color Blind Person Mode

Using this function, a user can adjust the red, green or blue colors according to the preferences of the partially color-blind person so that he or she can view the clearest possible picture on the screen.

Analog Broadcasting

Analog Broadcasting is a television broadcasting signal transmitted according to the NTSC standard.

ANTENNA IN Port

The port connecting the TV aerial via a coaxial cable. It is generally used for watching public broadcast programs.

English Caption

A function that displays English captions or text information included in the broadcast signal or video tape. You can use this function for your English studies by watching AFKN or CC marked video tapes.

Video/Audio Ports

You may experience poor visual and audio quality when watching a video tape on channel 3 or 4 through the antenna cable. You can experience better visual and audio quality by connecting the TV and VCR through the Video/Audio ports. The video port is in yellow, and the audio ports are in white and red.

Wide Screen

Wide Screen refers to a screen that is horizontally longer than a conventional TV screen.

While the aspect ratio of a normal TV is 4 : 3, that of a wide screen is 16 : 9.

External Input

External Input is a connected video device such as a VCR, camcorder, DTV receiver, DVD, etc. as a video source.

Satellite Broadcasting

Satellite Broadcasting transmits programs via satellite so that a program can be viable in all areas at a high visual and sound quality. Approximately 100 channels including public broadcast channels are provided. To view a satellite broadcast, you have to install an additional receiver.

Wire Broadcasting

Wire Broadcasting refers to movie, entertainment and educational programs transmitted by a broadcasting station within a hotel or school.

Audio Multimix

Audio Multimix provides 2 audio languages when foreign movie, drama, news, etc. are broadcast. You can select and listen to one of the supported languages or you can select and listen to both languages simultaneously.

After-Image Protection

Using this function, a user can configure the options necessary for protecting the PDP TV screen.

Power Saving Mode

This function adjusts the screen brightness according to the ambient brightness so as to conserve power.

Component Port

The Component Port transmits a separate luminance signal as well as the green, blue, and red color signal and provides the best quality of all video connection types.

Cable Broadcasting

Cable Broadcasting transmits programs via cable instead of via the air. To view cable broadcasting, you have to subscribe to your local cable broadcast service provider and install an additional receiver.

Tuner

A device that enables the selecting of specific channel frequencies for TV or radio.

Panorama Screen

This refers to a screen that corrects the picture distortion due to a screen size mismatch on the TV.

Progressive Scan

Progressive scan displays the entire frame in a single sweep so as to provide clearer and sharper visual quality.

Anynet

Anynet is an AV network system that enables an easy-to-use AV interface for users by controlling all connected AV devices through the Anynet menu when the AV devices of Samsung Electronics are connected.

DVD (Digital Versatile Disc)

DVD is a large capacity storage media that can store multimedia content such as video, games, audio applications, etc. using MPEG-2 video compression technology on a CD sized disc

DRC

This is a sound quality enhancement function that automatically controls audio output so as to prevent sound quality distortion even at loud volumes and correct the sound to the speakers so that you can listen to the sound at the original sound quality.

DVI (Digital Visual Interface) Port

A DVI interface is a standard for high definition television connectivity. It provides a clear picture on the screen using TMD5 which minimizes video signal loss.

DVI-D Cable

A type of DVI connector. Using this cable you can only transmit digital signals.

DVI-I Cable

A type of DVI connector. Using this cable you can transmit either digital or analog signals.

HDMI

HDMI (High-Definition Multimedia Interface) is the first industry-supported, uncompressed, all-digital audio/video interface. HDMI provides an interface between any audio/video source, such as a set-top box, DVD player, and A/V receiver and an audio and/or video monitor, such as a digital television (DTV). HDMI supports standard, enhanced, or high-definition video, plus multi-channel digital audio on a single cable. It transmits all ATSC HDTV standards and supports 8-channel digital audio, with bandwidth to spare to accommodate future enhancements and requirements.

PCM

PCM (Pulse Coded Modulation): This refers to an uncompressed digital signal. Use this for an AV amplifier that does not support 5.1 channels when connecting the audio output via optical or coaxial cable.

SRS TruSurround XT

This function provides 5.1 channel surround sound using 2 channel speakers when inputting a stereo audio signal.

VESA Plug & Play

This function enables the automatic recognition of devices when connecting the TV to the computer without additional settings.

S-VIDEO IN Port

This is called super video. S-Video is a type of video signal which has the video luminance and the color signal separated in order to provide better visual quality.

Pixels, Resolution

The pixels are the number of small dots that make up the TV screen. The resolution represents the number of pixels on a screen. For example, if the resolution of a TV is 852x480, it means the width of the screen consists of 852 pixel columns and the height of the screen consists of 480 pixel rows. In this case, the total number of pixels on the screen is 408,960. The more pixels there are, the higher the visual quality that can be achieved because the picture on the screen is displayed with more pixels and therefore with more detail.

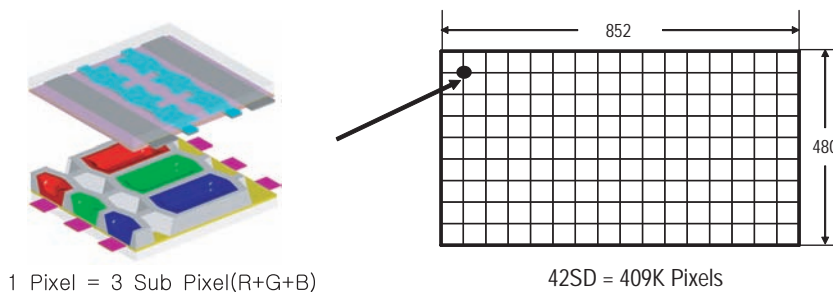

Gradation, Color Depth

Gradation describes the number of gradual brightness levels. Since all information is represented by binary numbers in a digital system, the Gradation is determined by the number of bits used to represent the brightness levels of a pixel on the TV screen. For example, if a pixel is represented by 8 bits, the Gradation is 28 or 256. Since a TV uses the three primary colors of light, R, G and B, the number of possible colors for a pixel is $256 \times 256 \times 256$, 16,777,216, or 16.7 million colors. If 12 bits are used for a pixel, the gradation is 212 or 4096 for a color. Since three colors R, G and B are used, $4096 \times 4096 \times 4096$ or 68.7 billion colors are supported per pixel. Since 68.7 billion colors are far more than 16.7 million colors, the picture will be displayed by far more abundant and natural colors using a 12 bit pixel. That is, since Gradation means the number of brightness levels, color represented by 4096 levels appears more natural than color represented by 256 levels.



Contrast

The contrast is the ratio of brightness of the brightest color to the darkest color. The contrast is calculated by dividing the brightness of the brightest color by the brightness of the darkest color. For example, if the brightness of the darkest color is 1 and the brightness of the brightest color is 3000, then the Contrast is $3000/1$ or 3000. A higher contrast means that a dark color is displayed darker and bright color is displayed brighter so that the screen contrast can be easily distinguished. The contrast differs from the Gradient which means the number of brightness levels.

Therefore, if someone says that a 5000:1 contrast displays a color by 5000 levels, he is confusing Contrast with Gradation.

Brightness

Brightness is the brightness per unit screen area, the unit for brightness is candela (cd). For example, 1000cd/m² means the brightness that is measured when 1000 candles are lit within 1 square meters area.

Color Reproductivity

Each color displayed on the TV screen is implemented by a pixel on color coordinates which have an X and Y axis.

For example, when a pixel on the X coordinate 0.65 and the Y coordinate 0.74 is displayed as a color and it becomes visible on the TV screen. While the possible color coordinate area is very wide, the color coordinate area of the signal broadcast from a broadcast station is smaller than that of possible color coordinates. Moreover, a TV provides a smaller color coordinate area than that of the signal from the broadcasting station even though the size of the color coordinate area varies depending on the TV model. In general, Color Reproductivity is used as follows:

The Color reproductivity of a TV is a certain % of NTSC. This means the TV displays that particular % of the color coordinate area of the NTSC signal broadcast by the broadcasting station. In general, a CRT TV provides the highest functional color reproductivity.

